

Viešoji įstaiga  
**KULTŪROS PAVELDO  
IŠSAUGOJIMO PAJĖGOS**

**Dalia Vaičiūnienė**

**VILNIAUS SENAMIESČIO (U. K. 16073) TERITORIJOS,  
ŽIUPRONIŲ G. 7 IR 9  
(VILNIUS, VILNIAUS MIESTO SAV.)  
2022 M. DETALIŲJŲ ARCHEOLOGINIŲ TYRIMŲ IR ŽVALGYMŲ ATASKAITA**

**IV tomas**

Brėžinių sąrašas ir brėžiniai

Vilnius, 2023 m.

## TURINYS

ĮVADAS	2
BRĖŽINIŲ SĄRAŠAS	5
BRĖŽINIAI	11

## ĮVADAS

Žiupronių g. 7 ir 9 sklypuose, Vilniuje, projektuojami nauji pastatai. Sklypai patenka į saugomą Vilniaus senamiesčio (u. k. 16073) teritoriją. Abu sklypai užima 5130 m<sup>2</sup> plotą, užstatymas planuojamas 3870 m<sup>2</sup> plote. Archeologiniai tyrimai (toliau – tyrimai) užsakyti projekto vystytojo – UAB „Dolversa“.

*Tyrimų tikslas* – prieš pradėdant statybas pilnai detaliųjų archeologinių tyrimų metodais iširti žemės judinimo vietose esančius kultūrinius sluoksnius, nustatyti jų chronologiją, fiksuoti stratigrafiją, archeologines ir/ar istorines struktūras bei kompleksus, surinkti archeologinius radinius.

Remiantis mokslinės archeologijos komisijos (toliau – MAK) patvirtintu tyrimų projektu (*1 priedas*) archeologei Daliai Vaičiūnienei išduotas leidimas (LA–199) tyrimams atlikti (*4 priedas*). Tyrimai atlikti 2022 m. birželio–lapkričio mėn.

*Tyrimų etapai, apimtys, pasirinkto archeologinių tyrimų pobūdžio pagrindimas.* Pagal MAK aprobuotą projektą tyrimai buvo vykdomi numatytais etapais:

1. Žvalgymai demontuojant garažus. Sklypai buvo užstatyti mūriniais garažais, kuriuos demontavus mechanizuotai pašalintos požeminės jų dalys – pamatai ir priedubės (42 vnt.).
2. Žvalgymai mechanizuotai planiruojant sklypus (užstatomą dalį) iki 1–1,3 m gylio nuo esamo žemės paviršiaus. Iš numatyto 3870 m<sup>2</sup> ploto nuplaniruota 3799,14 m<sup>2</sup>. Likusi užstatymo dalis (bendrai 70,86 m<sup>2</sup>) neplaniruota – Žiupronių g. 7 ŠV sklypo dalyje įrengta elektros transformatorinė (netirta 32,36 m<sup>2</sup>), o ties P pakraščiu sklypas ribojasi su gyvenamuoju namu, ūkiniu pastatu, tvora (*1 brėžinys*). Atsižvelgiant į saugumo reikalavimus nuo sklypo krašto buvo paliktas 3 m pločio laiptas (netirta 38,5 m<sup>2</sup>).
3. Atlikti sklypų (toliau – sklypo) kultūrinio sluoksnio pjūviai (perkasos Nr. 1–10, iš viso 234 m<sup>2</sup> plotas) – nustatytas preliminarus vertingų kultūrinių sluoksnių paplitimas.
4. Parengta tarpinė tyrimų pažyma. Ją aprobavus papildytas archeologinių tyrimų projektas – papildymas Nr. 1 ir Nr. 2 (*2–3 priedas*). Numatytas detaliųjų tyrimų plotas 2456,75 m<sup>2</sup>. Išaiškėjus, kad bet kurioje tiriamoje perkasoje archeologiškai vertingas kultūrinis sluoksnis pasibaigė, toliau perkasomis nebuvo tiriama – atlikti archeologiniai žvalgymai.

Tyrimų vadovė ir ataskaitos autorė archeologė Dalia Vaičiūnienė. Tyrimų grupė: archeologai Liudvikas Vasiliauskas, Vida Kliaugaitė, Zenonas Baubonis. Tyrimuose dalyvavo ir prie tyrimų ataskaitos parengimo prisidėjo archeologas Vytas Tomašauskas (atlikta tyrimų fotofiksacija, braižyti brėžiniai, inventorinti radiniai), Tomas Lekavičius (braižyti brėžiniai, inventorinti radiniai) ir Rytis Tamulynas (braižyti brėžiniai). T. p. prie archeologinių radinių identifikavimo prisidėjo dr. Eduardas Remecas (numizmatinė medžiaga), dr. Arūnas Puškorius (organiniai radiniai, jų konservavimas) ir dr. Egidijus Štavičius (akmeniniai kirvukai).

Antropologinę medžiagą ištyrė ir ataskaitą parengė dr. Justina Kozakaitė (7 priedas). Archeobotaninė medžiaga (grunto mėginiai, t. p. nuo grunto mėginių flotacijos metodu atskirtos liekanos) perduotos į Gamtos tyrimų centrą tolimesniems laboratoriniams tyrimams atlikti (8 priedas). Tyrimus atlieka dr. Dalia Kisielienė. Pabrėžtina, kad dėl didelio medžiagos kiekio (bendras surinktos, t. p. flotuotos medžiagos tūris 4555,5 litrai) laboratoriniai tyrimai užtruks. Šiuos tyrimus numatoma užbaigti iki 2025 m. birželio mėn. (9 priedas). Zooarcheologinės medžiagos tyrimus atliko ir ataskaitą parengė dr. Giedrė Piličiauskienė (13 priedas). Radioaktyviosios anglies tyrimai atlikti Fizinių ir technologijos mokslų centre „Mass Spectrometry“ laboratorijoje (10 priedas).

Tyrimų metu aptiktų statinių liekanų architektūros tyrimus atliko ir ataskaitą parengė VšĮ Architektūros tyrimų centras, šios įstaigos specialistės, t. y. Vitalija Veževičienė ir kt. (11 priedas). Kultūros paveldo departamento prie Kultūros ministerijos pirmosios nekilnojamojo kultūros paveldo vertinimo tarybos 2022–12–13 posėdyje buvo svarstytas klausimas dėl statinių liekanų, atidengtų vykdytų archeologinių tyrimų metu (12 priedas).

Tyrimų ataskaita suskirstyta į devynis tomus:

**I tomas** – tekstas;

**II tomas** – inventorintų archeologinių radinių lentelių sąrašas ir inventorintų archeologinių radinių lentelės (ypatieji radiniai, kokliai, numizmatinė medžiaga, metaliniai dirbiniai, stikliniai dirbiniai, čerpės ir plytos, akmens ir titnago dirbiniai, pypkių vamzdėliai, kauliniai dirbiniai, odiniai ir kt. radiniai);

**III tomas** – inventorintų archeologinių radinių lentelių sąrašas ir inventorintų archeologinių radinių lentelės (buitinė keramika);

**IV tomas** – brėžinių sąrašas ir brėžiniai;

**V tomas** – nuotraukų sąrašas ir nuotraukos (1–20 perkasa, žvalgymai);

**VI tomas** – nuotraukų sąrašas ir nuotraukos (21–41 perkasa, žvalgymai);

**VII tomas** – nuotraukų sąrašas ir nuotraukos (archeologiniai radiniai);

**VIII tomas** – priedų sąrašas ir priedai:

- archeologinių tyrimų projektas (6 p.);
- archeologinių tyrimų projekto papildymas Nr. 1 ir Nr. 2 (14 p. ir 46 p.);
- leidimas atlikti archeologinius tyrimus (83 p.);
- archeologinių tyrimų pažyma (84 p.);
- radinių perdavimo aktai (101 p.);
- antropologinė ataskaita (154 p.);
- bioarcheologinės (archeobotaninės) medžiagos perdavimo–priėmimo aktas (158 p.);

- patvirtinimas apie atliekamus archeobotaninės medžiagos laboratorinius tyrimus (161 p.);
- radioaktyviosios anglies tyrimų protokolas (162 p.).

**IX tomas** – priedų sąrašas ir priedai:

- statinių liekanų architektūros tyrimų ataskaita (6 p.);
- statinių liekanų, atidengtų archeologinių tyrimų metu Vilniuje, Žiupronių g. 7, 9, vertinimo protokolas (57 p.);
- zooarcheologinės medžiagos tyrimų ataskaita (62 p.).

Santrumpos naudojamos ataskaitoje: gr. – griuvenos; p. ž. – pilka žemė; j. ž. – juoda žemė; t. p. ž. – tamsiai pilka žemė; Kv. – kvadratas; Inv. Nr. – inventorinis numeris; Nuotr. – nuotrauka; P-1 – perkasa ir jos numeris; Obj. Nr. 100/1 – objektas, jo eilės numeris ataskaitoje ir numeris naudotas tyrimų metu (matomas nuotraukoje).

## BRĖŽINIŲ SĄRAŠAS

1. Tyrimų situacijos planas
2. Sutartiniai žymėjimai
3. P-1 t. p. ž. sluoksnio (XV a.) sit. planas (0,4–0,9 m gylis)
4. P-1 obj. sit. planas įžemyje (0,55–1,05 m gylis)
5. Obj. Nr. 1/1–2/2, 5/5
6. P-1 Š, R, P, V sienų pjūviai
7. P-2 t. p. ž. sluoksnio (XV a.) sit. planas (0,3–1 m gylis)
8. P-2 obj. sit. planas įžemyje (0,45–1,15 m gylis)
9. Obj. Nr. 10/3–11/4, 13/6
10. P-2 Š, R sienų pjūviai
11. P-2 P, V sienų pjūviai
12. P-3 t. p. ž. sluoksnio (XV a.) sit. planas (0,3 m gylis); P-3 obj. sit. planas įžemyje (0,4 m gylis)
13. P-4 sit. planas (0,2 m gylis); P-4 aptiktų puodų sit. planas (1,1–1,4 m gylis)
14. P-5 t. p. ž. sluoksnio (XV a.) sit. planas (0,1–0,2 m gylis)
15. P-5 obj. sit. planas įžemyje (0,2–0,4 m gylis)
16. Obj. Nr. 20/1, 22/3, 24/1
17. P-3, R, P sienų pjūviai; P-4, Š, P sienų pjūviai; P-5 R sienos pjūvis (Kv. Y10–Y19); P-5 V sienos pjūvis (Kv. Y14–10)
18. P-6 obj. sit. planas įžemyje (0,4 m gylis); P-6 R (Kv. X28), V sienų pjūviai; P-7 sit. planas (0,6–0,8 m gylis)
19. P-8 t. p. ž. sluoksnio (XV a.) sit. planas (0,3–0,35 m gylis); P-8 obj. sit. planas įžemyje (0,4–0,45 m gylis)
20. P-7 R sienos pjūvis; P-8 R, P, V sienų pjūviai
21. P-9 sit. planas (0,2 m gylis); P-9 sit. planas (0,6 m gylis)
22. P-9 t. p. ž. sluoksnio (XV a.) sit. planas (1–1,3 m gylis); P-9 obj. sit. planas įžemyje (1,2–1,45 m gylis)
23. Obj. Nr. 27/2–29/4
24. P-10 sit. planas (0,2 m gylis); P-10 sit. planas (0,8 m gylis)
25. P-10 t. p. ž. sluoksnio (XV a.) sit. planas (1,2 m gylis); P-10 obj. sit. planas įžemyje (1,3–1,35 m gylis)
26. Obj. Nr. 35/5 planas; Obj. Nr. 35/5 viršutinė pjūvio dalis
27. Obj. Nr. 35/5 planas (aptikus medinį kontūrą); Obj. Nr. 35/5 pjūvis
28. P-9 Š, R, V sienų pjūviai; P-10 Š, P, V sienų pjūviai

29. P-11 sit. planas (0,2 m gylis)
30. P-11 t. p. ž. sluoksnio (XV a.) sit. planas (1 m gylis)
31. P-11 obj. sit. planas įžemyje (1,15–1,2 m gylis)
32. Obj. Nr. 40/4–43/7
33. Obj. Nr. 44/8–50/14
34. P-11 P, V sienų pjūviai
35. P-12 t. p. ž. sluoksnio (XV a.) sit. planas (0,6 m gylis)
36. P-12 sit. planas (0,75–0,8 m gylis)
37. P-12 P sienos pjūvis; P-12 V sienos pjūvis (Kv. Y28–Y23)
38. Gyvenamojo namo Nr. P1 fragm. planas
39. Gyvenamojo namo Nr. P1 rūsio P, V sienos
40. Gyvenamojo namo Nr. P1 rūsio Š, R sienos
41. Gyvenamojo namo Nr. P1 Š, R sienos ir obj. Nr. 51/1
42. P-13 t. p. ž. sluoksnio (XV a.) sit. planas (0,8–0,9 m gylis)
43. P-13 obj. sit. planas įžemyje (1–1,1 m gylis)
44. P-13 P, ŠV sienų pjūviai
45. P-14 sit. planas (0,2 m gylis)
46. P-14 t. p. ž. sluoksnio (XV a.) sit. planas (0,5–0,6 m gylis)
47. P-14 obj. sit. planas įžemyje (0,6–0,7 m gylis)
48. P-14 P sienos pjūvis; P-14 V sienos pjūvis (Kv. Y28–Y23); Obj. Nr. 55/1 pjūvis
49. Obj. Nr. 60/6–62/8
50. P-15 t. p. ž. sluoksnio (XV a.) sit. planas (0,3–0,6 m gylis)
51. P-15 obj. sit. planas įžemyje (0,45–0,75 m gylis)
52. Obj. Nr. 64/3, 68/7, 80/19
53. Obj. Nr. 69/8–72/11
54. Obj. Nr. 73/12–75/14, 78/17
55. Obj. Nr. 77/16, 81/20
56. Obj. Nr. 82/21 planas
57. Obj. Nr. 82/21 konstrukcijos ir užpildo pjūvis
58. P-16 sit. planas (0,1–0,2 m gylis); P-16 sit. planas (0,4–0,5 m gylis)
59. P-16 t. p. ž. sluoksnio (XV a.) sit. planas (1,5–1,6 m gylis); P-16 obj. sit. planas įžemyje (1,6–1,7 m gylis)
60. P-17 sit. planas (0,2 m gylis)
61. P-17 sit. planas (0,7–0,9 m gylis)
62. P-17 t. p. ž. sluoksnio (XV a.) sit. planas (1–1,1 m gylis)

63. P-17 obj. sit. planas įžemyje (1,2 m gylis)
64. P-15 P sienos pjūvis; P-15 ŠV sienos pjūvis (KV. Y27-Y19); P-16 Š, V sienų pjūviai; P-17 Š, R sienų pjūviai
65. P-18 sit. planas (0,2 m gylis)
66. P-18 t. p. ž. sluoksnio (XV a.) sit. planas (0,9-1 m gylis)
67. P-18 obj. sit. planas įžemyje (1-1,15 m gylis)
68. P-18 Š sienos pjūvis
69. Obj. Nr. 83/1-86/2
70. Obj. Nr. 87/3-94/10
71. Obj. Nr. 95/11-96/12, 98/14, 100/3
72. P-19 sit. planas (0,2 m gylis)
73. P-19 t. p. ž. sluoksnio (XV a.) sit. planas (0,5-1,3 m gylis)
74. P-19 obj. sit. planas įžemyje (0,55-1,4 m gylis)
75. Obj. Nr. 101/1-103/3
76. Obj. Nr. 104/4-108/9
77. Obj. Nr. 109/10, 111/12
78. P-19 Š, R, P sienų pjūviai
79. Gyvenamojo namo Nr. P2 fragm. planas
80. Gyvenamojo namo Nr. P2 rūsio Š, R sienos
81. Gyvenamojo namo Nr. P2 rūsio P, V sienos
82. P-20 sit. planas (0,2 m gylis); P-20 obj. sit. planas įžemyje (0,8-1 m gylis)
83. P-20 Š, R sienų pjūviai
84. P-21 sit. planas (0,2 m gylis)
85. P-21 t. p. ž. sluoksnio (XV a.) sit. planas (0,6 m gylis)
86. P-21 obj. sit. planas įžemyje (0,8 m gylis)
87. Obj. Nr. 113/2-114/3
88. Obj. Nr. 115/4-116/5, 118/7, 120/9
89. Obj. Nr. 121/10-124/13
90. P-22 sit. planas (0,2 m gylis)
91. P-22 t. p. ž. sluoksnio (XV a.) sit. planas (0,5-0,6 m gylis)
92. P-22 obj. sit. planas įžemyje (0,5-0,6 m gylis)
93. Obj. Nr. 126/1-130/5, 131/7-133/9
94. P-21 R, P sienų pjūviai; P-22 P sienos pjūvis
95. P-23 sit. planas (0,2 m gylis)
96. P-23 t. p. ž. sluoksnio (XV a.) sit. planas (0,4 m gylis)









97. P–23 obj. sit. planas įžemyje (0,5–0,6 m gylis)
  - 97.1 Obj. Nr. 135/2–139/6
98. Obj. Nr. 140/7–145/12
99. Obj. Nr. 146/13–151/18
100. Obj. Nr. 152/19, 154/21–155/22
101. P–24 t. p. ž. sluoksnio (XV a.) sit. planas (0,1–0,3 m gylis)
102. P–24 obj. sit. planas įžemyje (0,4–0,5 m gylis)
103. Obj. Nr. 156/1–160/5
104. Obj. Nr. 161/6–164/9, 166/11
105. Obj. Nr. 167/12–170/15
106. P–23 R, P sienų pjūviai; P–24 P sienos pjūvis (Kv. X44–X38)
107. P–25 t. p. ž. sluoksnio (XV a.) sit. planas (0,4–0,8 m gylis)
108. P–25 obj. sit. planas įžemyje (0,6–1,2 m gylis)
109. P–26 t. p. ž. sluoksnio (XV a.) sit. planas (0,8–0,9 m gylis); P–26 obj. sit. planas įžemyje (1 m gylis)
110. Obj. Nr. 171/1–172/3
111. Obj. Nr. 173/4–174/1
112. Obj. Nr. 175/2
113. P–25 R, P sienų pjūviai; P–26 R (Kv. Y14–Y15), P–26 P sienų pjūviai
114. P–27 obj. sit. planas įžemyje (0,6 m gylis)
115. 177/1, 180/4–183/7, 185/9
116. P–27 R sienos pjūvis
117. Krosnies Nr. K1 planas
118. P–28 t. p. ž. sluoksnio (XV a.) sit. planas (0,4 m gylis); P–28 obj. sit. planas įžemyje (0,6 m gylis)
119. Obj. Nr. 190/1–198/9
120. P–29 t. p. ž. sluoksnio (XV a.) sit. planas (0,3–0,45 m gylis); P–29 obj. sit. planas įžemyje (0,5–0,55 m gylis)
121. Obj. Nr. 199/1–204/6
122. P–28 P, V sienų pjūviai; P–29 R, P sienų pjūviai
123. P–30 t. p. ž. sluoksnio (XV a.) sit. planas (0,15–0,2 m gylis); Gyvenamojo namo Nr. P3 sit. planas
124. P–30 obj. sit. planas įžemyje (0,3–0,4 m gylis); Gyvenamojo namo Nr. P3 sit. planas
125. Obj. Nr. 205/1–206/2, 209/5, 211/7–212/8

126. P-30 R sienos pjūvis; P-30 P sienos pjūvis (Kv. X33, Kv. X25-X20);  
P-30 V sienos pjūvis (Kv. Y38-Y35)
127. P-31 sit. planas (0,15-0,2 m gylis); P-31 obj. sit. planas įžemyje (0,15-0,6 m gylis)
128. P-31 Š, P sienų pjūviai
129. P-32 t. p. ž. sluoksnio (XV a.) sit. planas (0,4 m gylis)
130. P-32 obj. sit. planas įžemyje (0,5-0,6 m gylis)
131. Obj. Nr. 215/1-216/2, 218/4-223/9
132. Obj. Nr. 225/11
133. P-32 P, V sienų pjūviai
134. P-33 t. p. ž. sluoksnio (XV a.) sit. planas (0,2 m gylis)
135. P-33 obj. sit. planas įžemyje (0,3-0,4 m gylis)
136. Obj. Nr. 227/2-228/3, 229/7-231/9
137. Obj. Nr. 233/15-234/16
138. P-33 P sienos pjūvis (Kv. X10-X2)
139. P-33 V sienos (Obj. Nr. 226/1) pjūvis
140. Krosnių Nr. K3.1-K3.2 planas
141. P-34 t. p. ž. sluoksnio (XV a.) sit. planas (0,4-0,6 m gylis)
142. P-34 obj. sit. planas įžemyje (0,6-0,8 m gylis)
143. Obj. Nr. 236/2
144. Obj. Nr. 239/5, 242/8, 244/10-247/13
145. Obj. Nr. 248/14-249/15
146. Obj. Nr. 250/16-252/18
147. P-34 P, PV sienų pjūviai
148. P-35 t. p. ž. sluoksnio (XV a.) sit. planas (0,5 m gylis)
149. P-35 obj. sit. planas įžemyje (0,7 m gylis)
150. Obj. Nr. 258/4-260/6, 262/8
151. Obj. Nr. 263/9-267/13, 269/15-271/17
152. Obj. Nr. 273/19-274/20, 279/25-283/29
153. Obj. Nr. 285/31-288/34
154. P-35 R sienos pjūvis (Kv. Y43-Y46); P-35 P, PV sienų pjūviai
155. P-36 t. p. ž. sluoksnio (XV a.) sit. planas (0,5 m gylis)
156. P-36 obj. sit. planas įžemyje (0,6-0,7 m gylis)
157. Obj. Nr. 290/2-296/7, 297/9-298/10
158. P-36 P, PV sienų pjūviai
159. P-37 t. p. ž. sluoksnio (XV a.) sit. planas (0,45-0,5 m gylis)

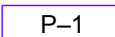
160. P-37 obj. sit. planas įžemyje (0,6 m gylis)
161. P-37 PV sienos pjūvis
162. P-37 V sienos pjūvis
163. P-38 t. p. ž. sluoksnio (XV a.) sit. planas (0,1–0,15 m gylis)
164. P-38 obj. sit. planas įžemyje (0,25–0,3 m gylis)
165. Obj. Nr. 307/3–308/4, 311/7
166. P-39 t. p. ž. sluoksnio (XV a.) sit. planas (0,1–0,2 m gylis)
167. P-39 obj. sit. planas įžemyje (0,4 m gylis)
168. Obj. Nr. 313/1
169. Obj. Nr. 314/2–317/5
170. Obj. Nr. 318/6–325/13
171. Obj. Nr. 326/14–329/1
172. Obj. Nr. 330/18–333/21, 337/1–338/2
173. P-38 P sienos pjūvis (Kv. X46–x45); P-38 P sienos pjūvis (Kv. X36–X34);  
P-39 P sienos pjūvis (Kv. X45–X39); P-39 V sienos pjūvis (Kv. Y44–Y43)
174. Krosnies Nr. K2 planas
175. Krosnies Nr. K2 užpildo pjūvis ir išorė (Š pusė)
176. Krosnies Nr. K2 Š, V siena
177. Krosnies Nr. K2 R, P siena
178. P-40 obj. sit. planas įžemyje (0,3–0,6 m gylis); P-41 obj. sit. planas įžemyje (0,3–0,5 m gylis)
179. Obj. Nr. 337/1–338/2
180. Obj. Nr. 339/3–342/6, 189/13
181. P-40 R sienos pjūvis; P-40 V sienos pjūvis (Kv. Y19–Y16); P-40 (Kv. X62) ir P-41 (Kv. X61–X59) P sienos pjūvis
182. Obj. Nr. 344/1–349/6
183. Obj. Nr. 350/7
184. Obj. Nr. 351/8–354/11, 356/13–360/17
185. Obj. Nr. 381/8–362/21
186. Obj. Nr. 355/12
187. Krosnies Nr. K5 planas

## SUTARTINIAI ŽENKLAI

-  Žiupronių g. 7 ir 9 sklypų riba
-  Archeologinių žvalgymų plotas nukasant iki 1,3 m gylio (3799,14 m<sup>2</sup>)
-  P-1 2022 m. iširtos perkastos (2450,75 m<sup>2</sup>)
-  2020 m. tyrimų vietos
-  2022 m. iširtos kultūrinio sluoksnio plotas (~2230 m<sup>2</sup>)
-  Dėl įrengtos infrastruktūros netirtas plotas (70,86 m<sup>2</sup>)
-  -1 Objektas

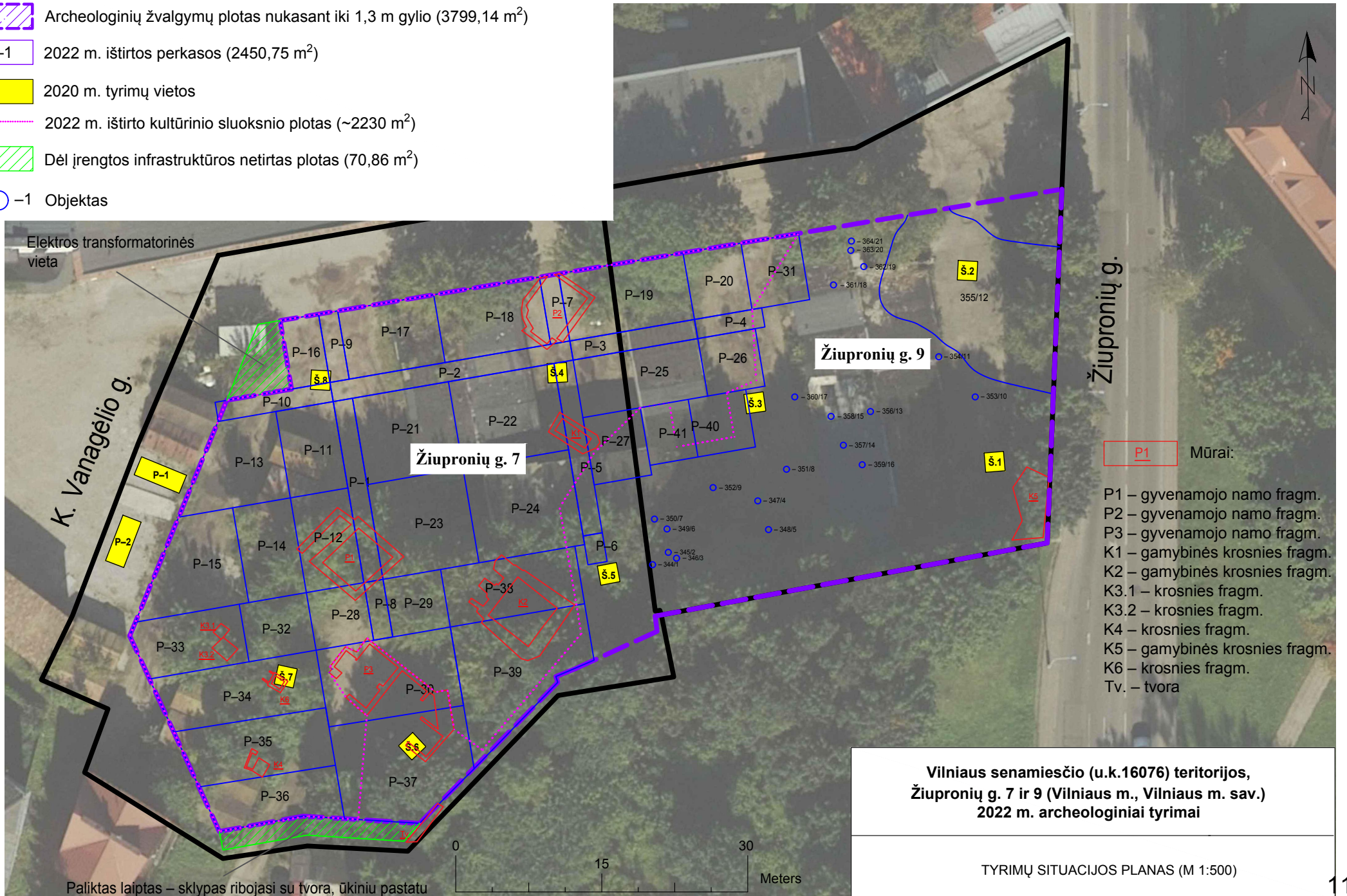

**P1** Mūrai:

- P1 – gyvenamojo namo fragm.
- P2 – gyvenamojo namo fragm.
- P3 – gyvenamojo namo fragm.
- K1 – gamybinės krosnies fragm.
- K2 – gamybinės krosnies fragm.
- K3.1 – krosnies fragm.
- K3.2 – krosnies fragm.
- K4 – krosnies fragm.
- K5 – gamybinės krosnies fragm.
- K6 – krosnies fragm.
- Tv. – tvora

**Vilniaus senamiesčio (u.k.16076) teritorijos,  
Žiupronių g. 7 ir 9 (Vilniaus m., Vilniaus m. sav.)  
2022 m. archeologiniai tyrimai**

TYRIMŲ SITUACIJOS PLANAS (M 1:500)



Mišrus gruntas

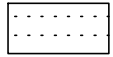

Šviesus erozinis smėlis

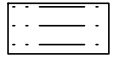

Mišrus rudo molio ir šviesaus smėlio gruntas

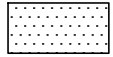

Geltonas smėlis (įžemis)

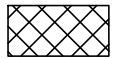

Supiltinis gruntas (XX a. perkasimas)

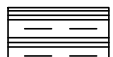

Rudas molis

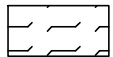

Žalsvas, organikos paveiktas, molis

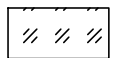

Betonas

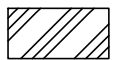

Asfaltas

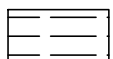

Molingas, t. p. mišrus molio, juodos žemės gruntas (prisotintas drėgmės ir organikos)

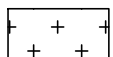

Žalsvas, organikos paveiktas molis su degėšiais

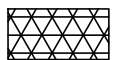

Kalės ir griuvenos (sukibusios į vientisą struktūrą), kalkių skiedinys

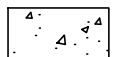

Šviesus (gelsvas, balkšvas) smėlis

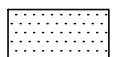

Šviesus, geltonas smėlis (įžemis)



Akmenys

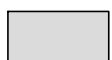

Plyta



Buitinės keramikos šukė (puodas)

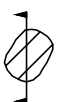

Objektas, jo nueris ir pjūvio kryptis

Obj. Nr. 28/3



Žmogaus kaulai

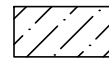

Šviesiai pilka žemė



Tamsiai pilka žemė



Juoda, tamsiai pilka žemė

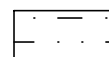

Organika

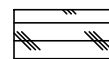

Griuvenos



Mediena

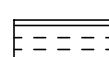

Žvyras

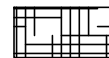

Kalkės

Sutartiniai žymėjimai

Brėžinys Nr. 2

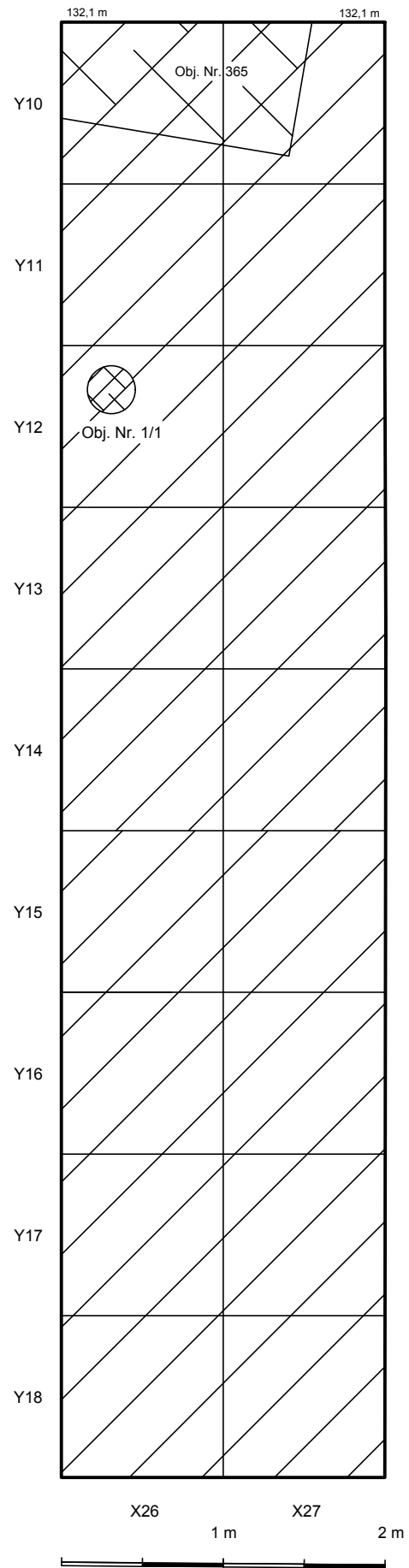
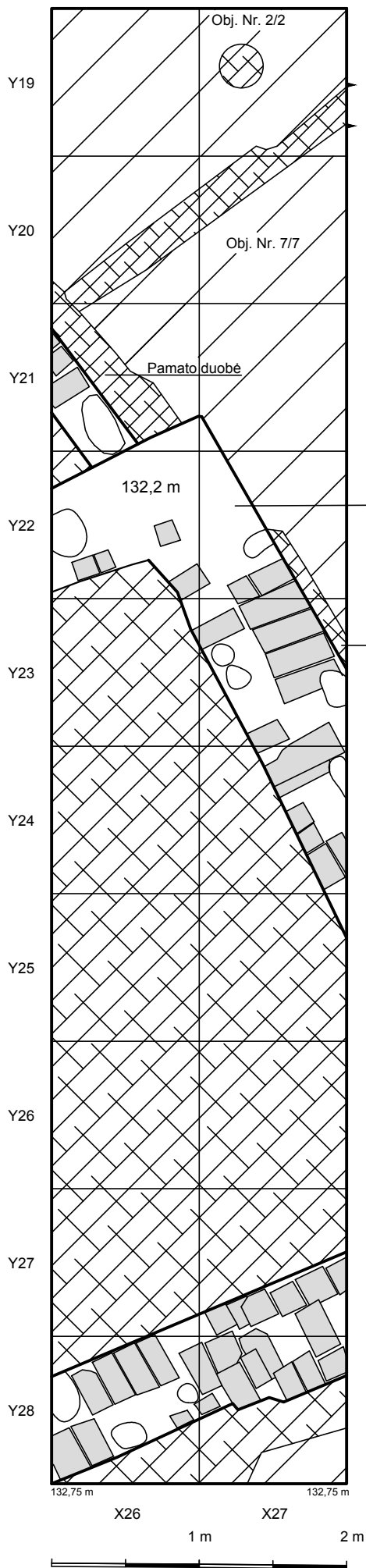

P-1 t. p. ž. sluoksniu (XV a.) sit. planas  
(0,4–0,9 m gylis)

M1:40

Brėžinys Nr. 3

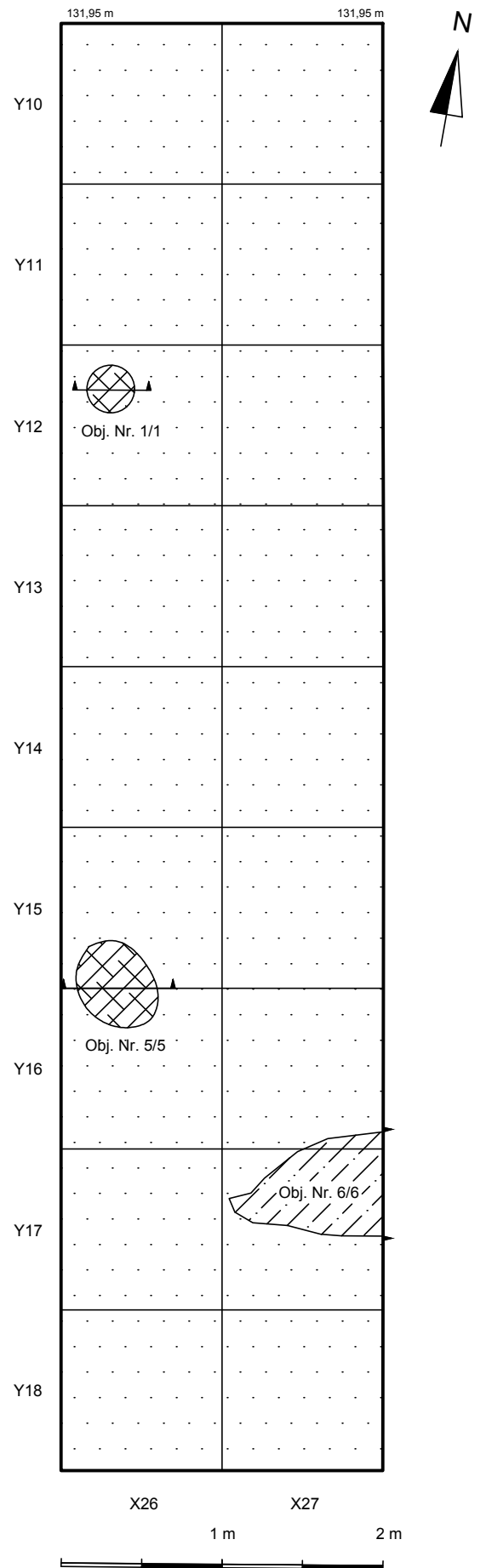
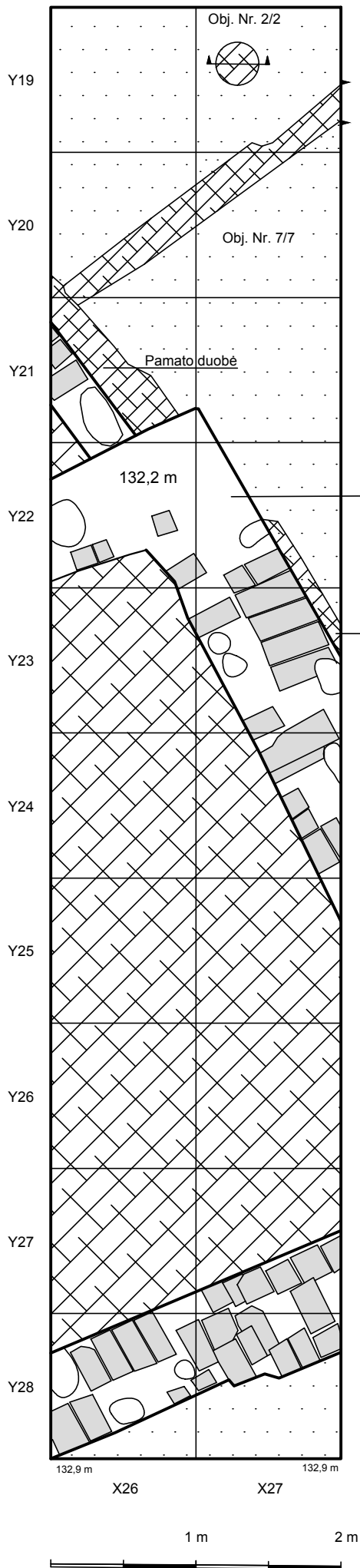

P-1 obj. sit. planas įžemyje (0,55–1,05 m gylis)

M1:40

Brėžinys Nr. 4

Obj. Nr. 1/1

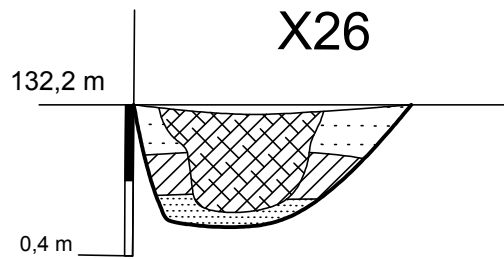

Obj. Nr. 2/2

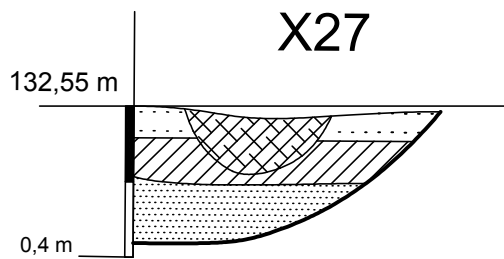

Obj. Nr. 5/5

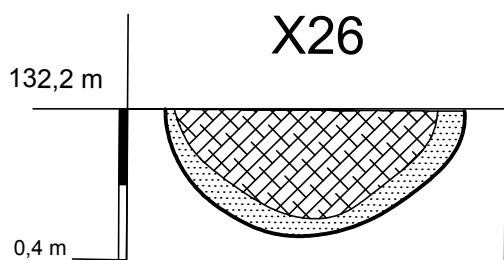

Obj. Nr. 1/1–2/2, 5/5

M1:20

Brėžinys Nr. 5



P-1 Š sienos pjūvis

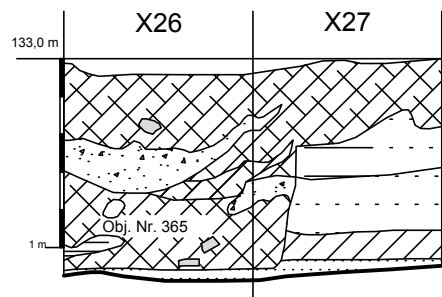

P-1 R sienos pjūvis (Kv. Y10-Y21)

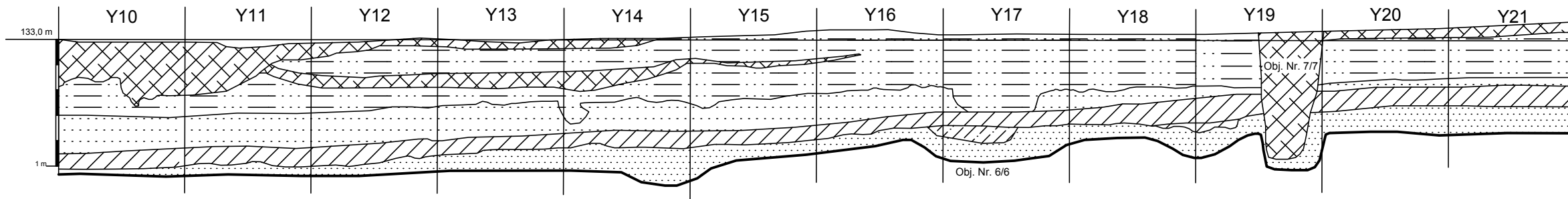

P-1 V sienos pjūvis (Kv. Y21-Y10)

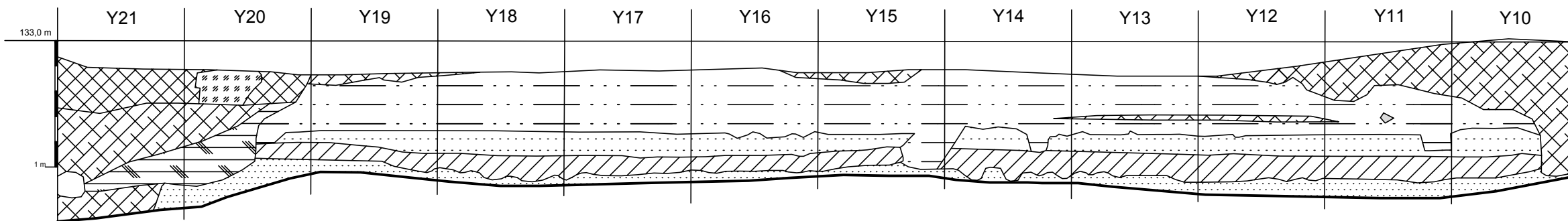

P-1 P sienos pjūvis

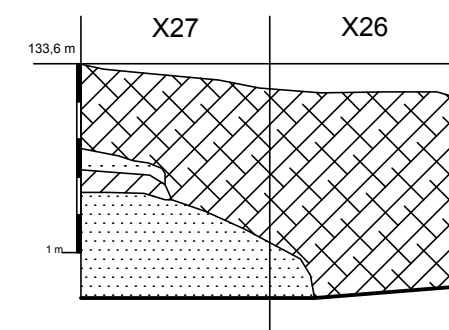

P-1 V sienos pjūvis (Kv. Y28-Y22)

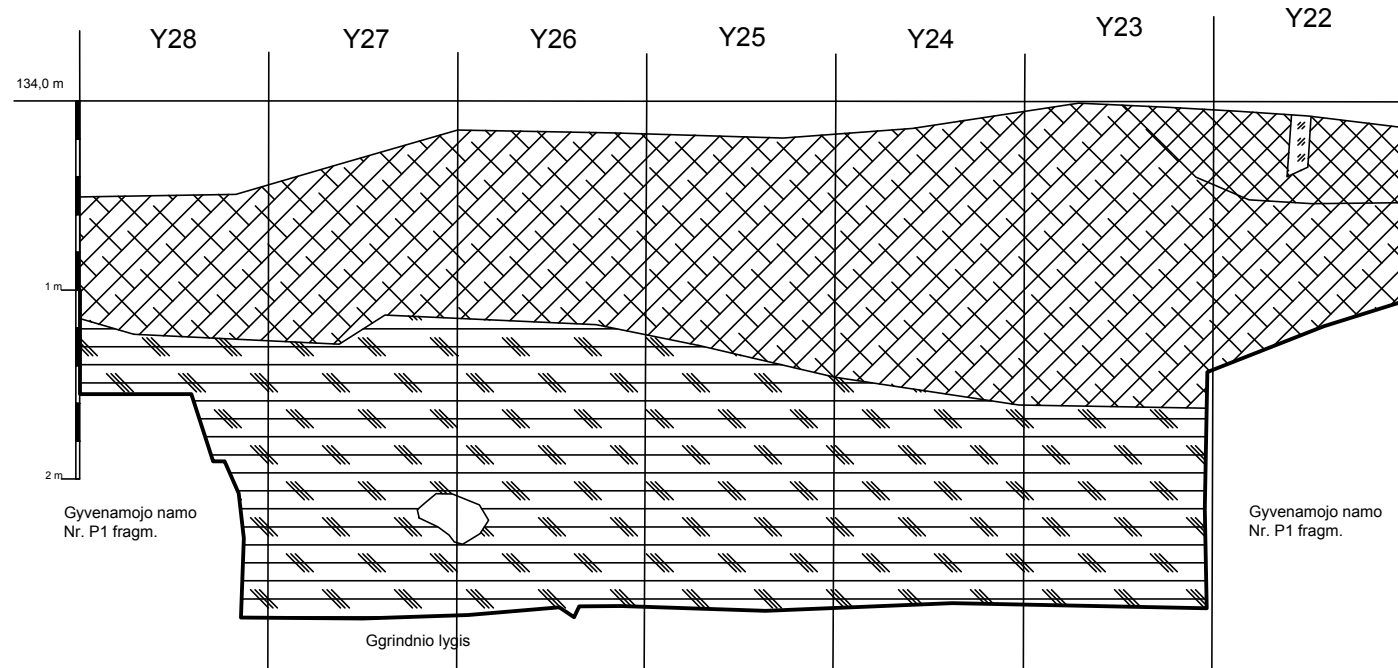

P-1 R sienos pjūvis (Kv. Y22-Y28)

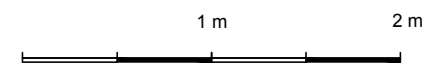
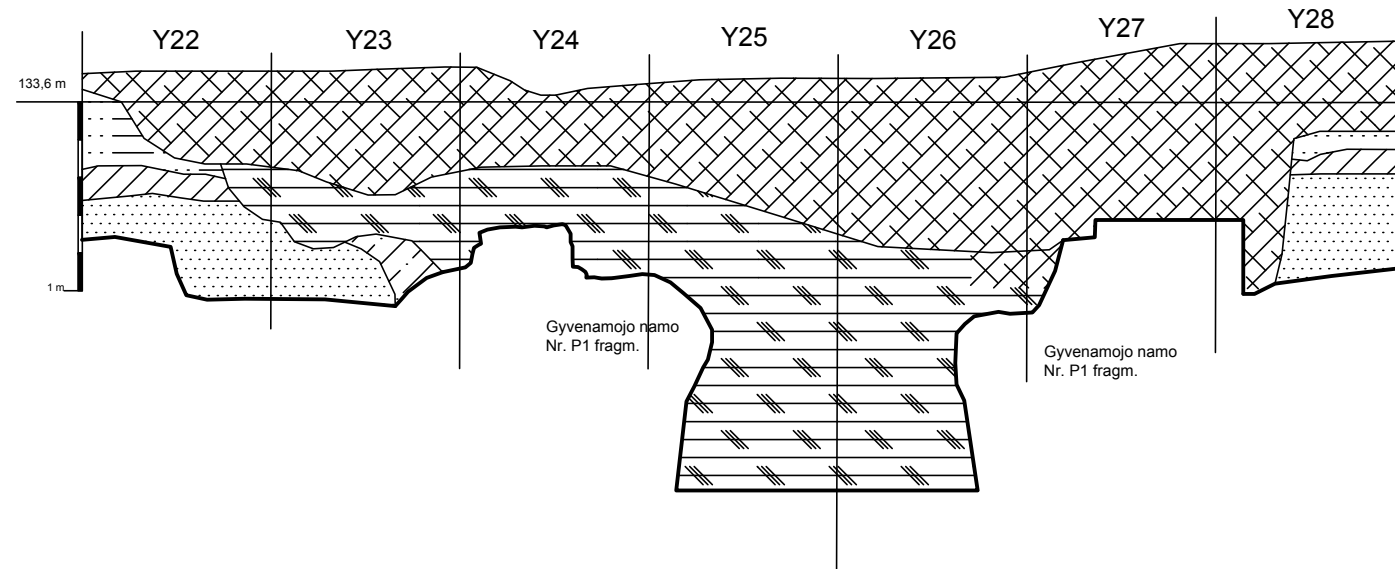

P-1 Š, R, P, V sienų pjūviai

M1:40

Brėžinys Nr. 6

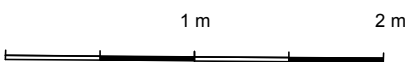
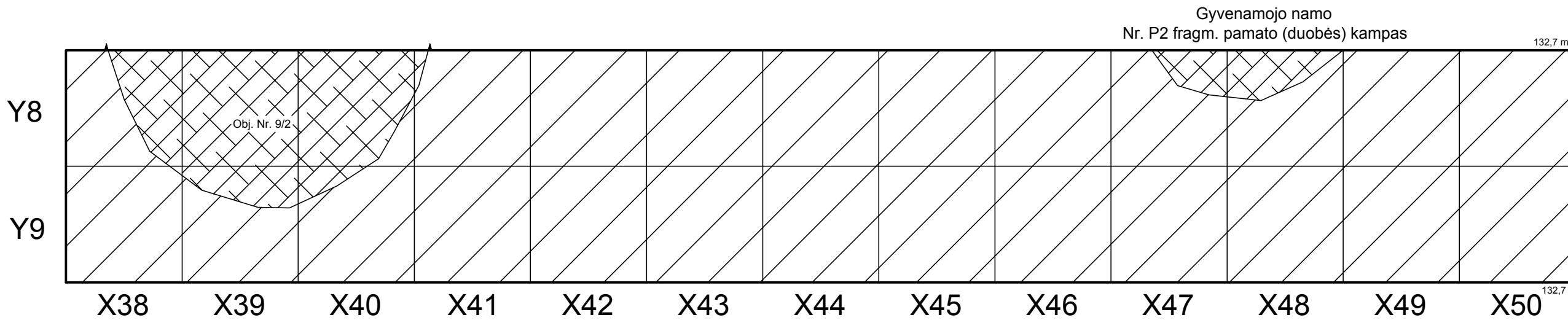
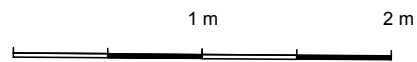
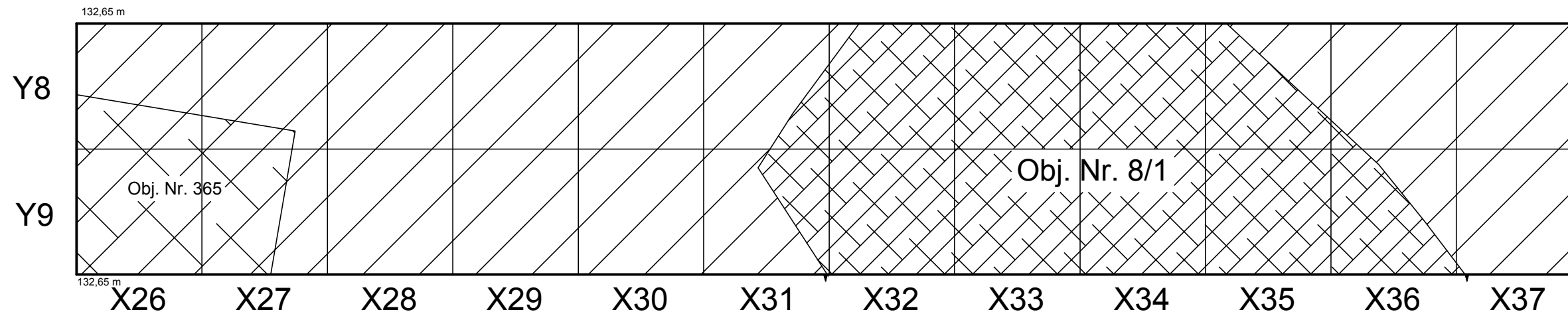

P-2 t. p. ž. sluoksniu (XV a.) sit. planas (0,3–1 m gylis)
M1:40
Brėžinys Nr. 7

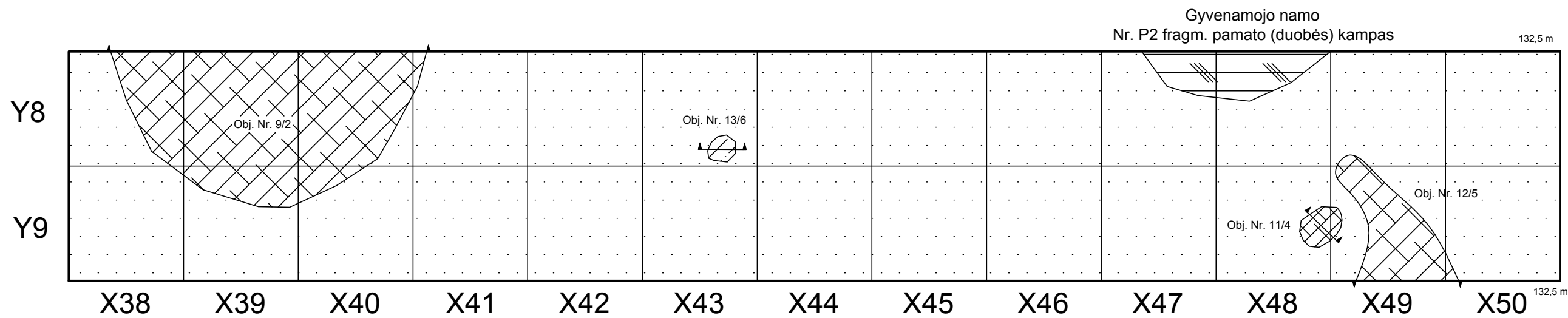
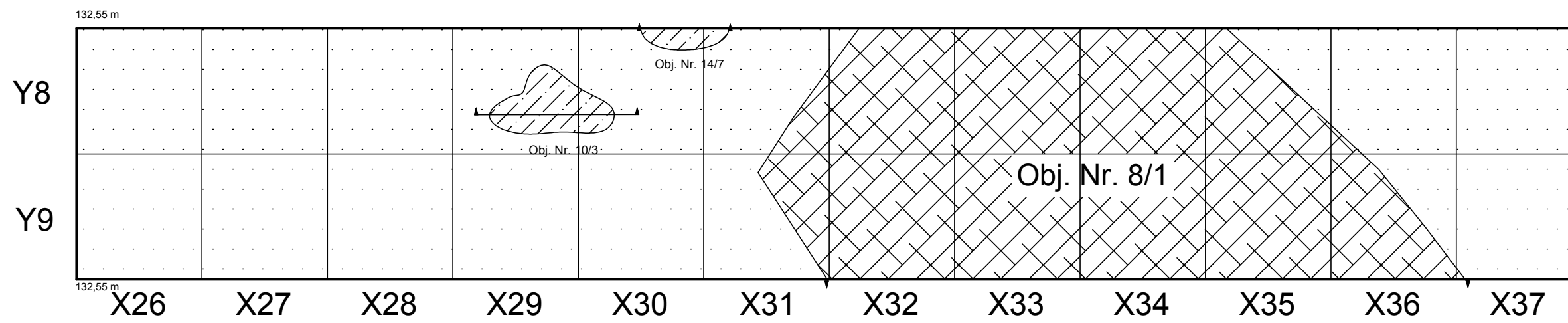

P-2 obj. sit. planas įžemyje (0,45–1,15 m gylis)

M1:40

Brėžinys Nr. 8

Obj. Nr. 10/3

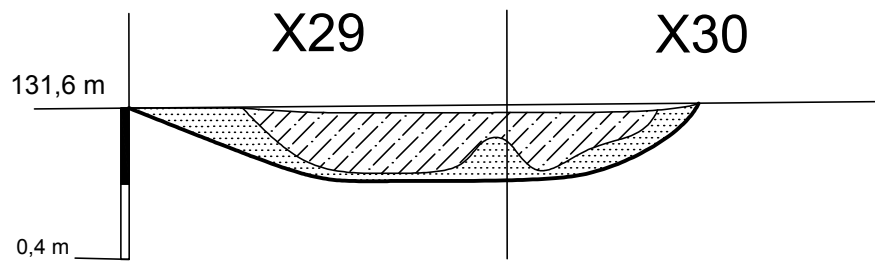

Obj. Nr. 11/4

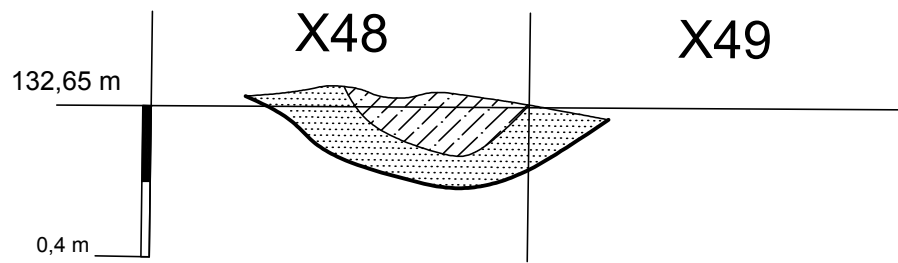

Obj. Nr. 13/6

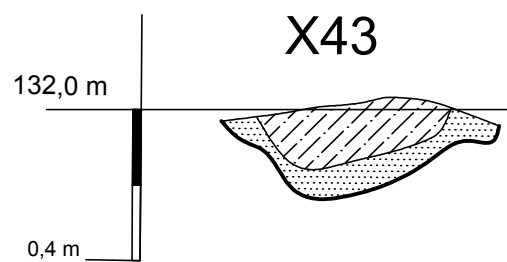

Obj. Nr. 10/3–11/4, 13/6

M1:20

Brėžinys Nr. 9

P-2 Š sienos pjūvis (Kv. X26-X37)

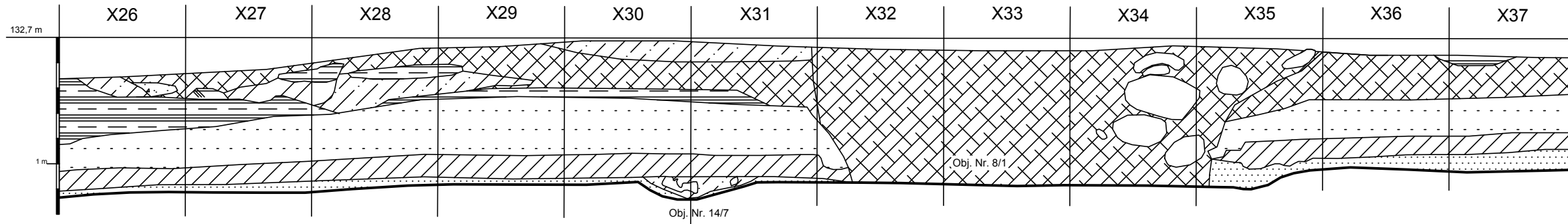

P-2 Š sienos pjūvis (Kv. X38-X50)

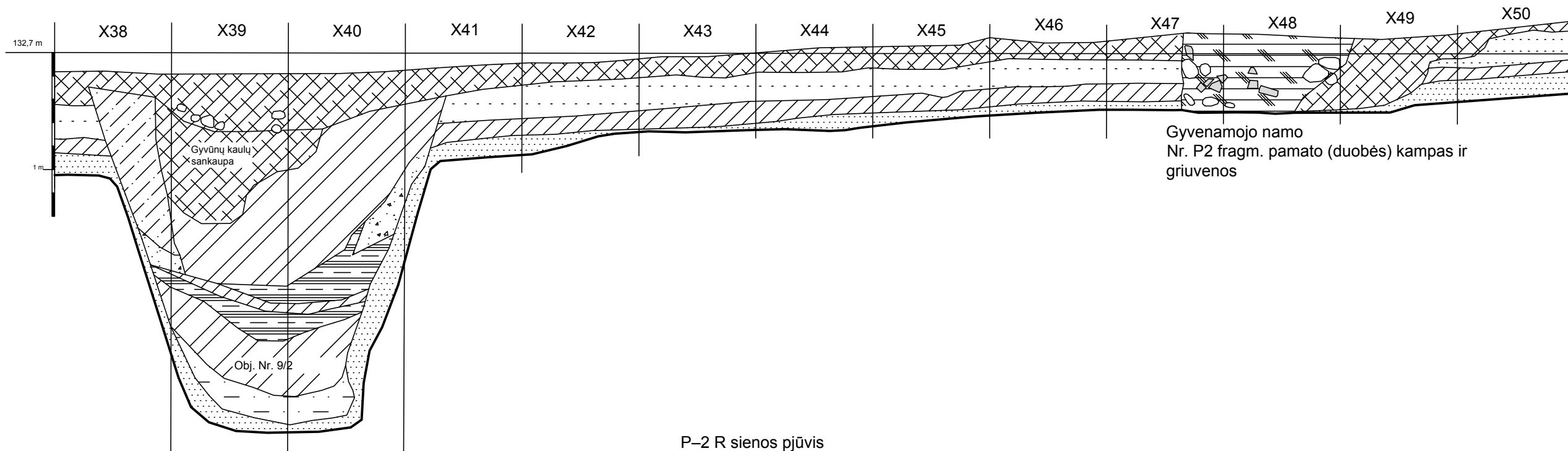

P-2 R sienos pjūvis

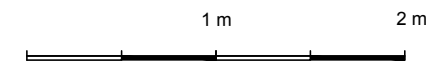
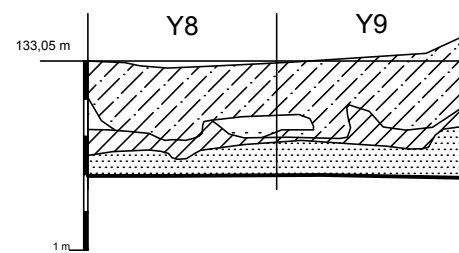

P-2 Š, R sienų pjūviai

M1:40

Brėžinys Nr. 10

P-2 P sienos pjūvis (Kv. X50-X39)

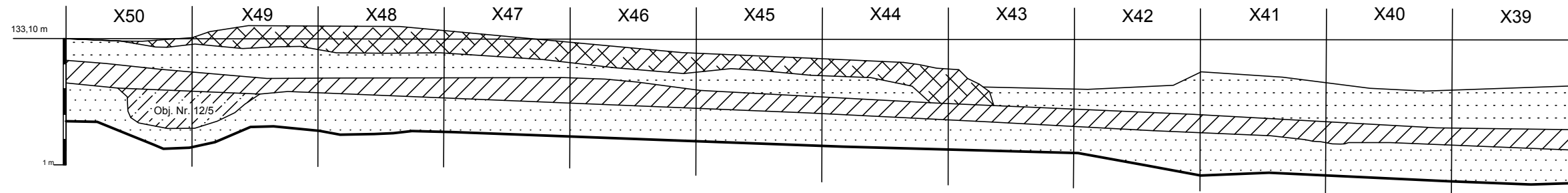

P-2 P sienos pjūvis (Kv. X38-X28)

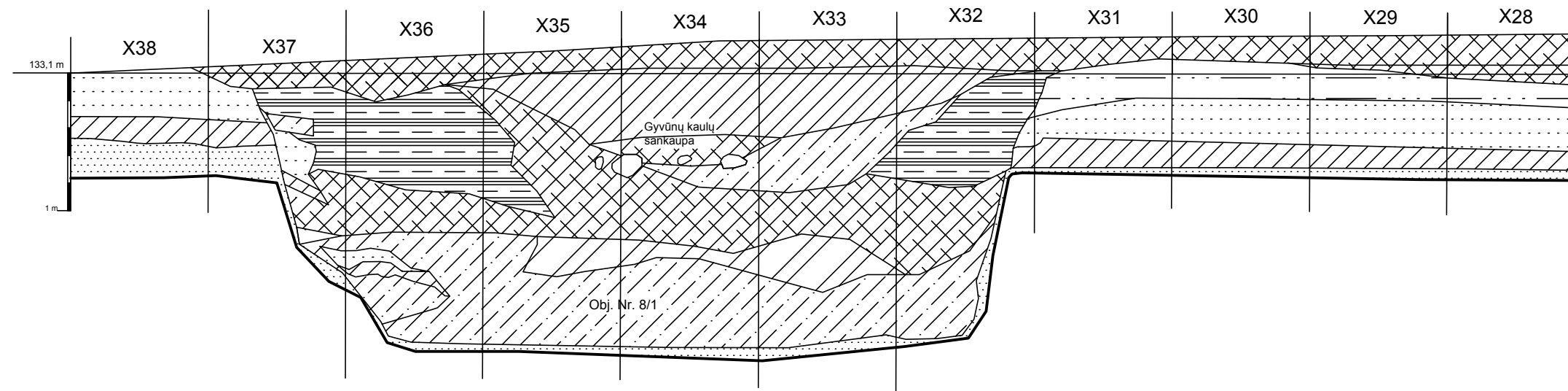

P-2 V sienos pjūvis

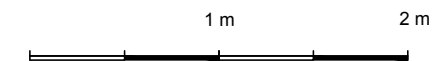
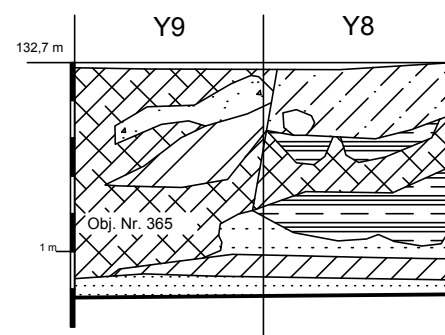

P-2 P, V sienų pjūviai

M1:40

Brėžinys Nr. 11

P-3 sit. planas t. p. ž. (XV a.) sluoksnyje  
(0,1–0,2 m gylis)

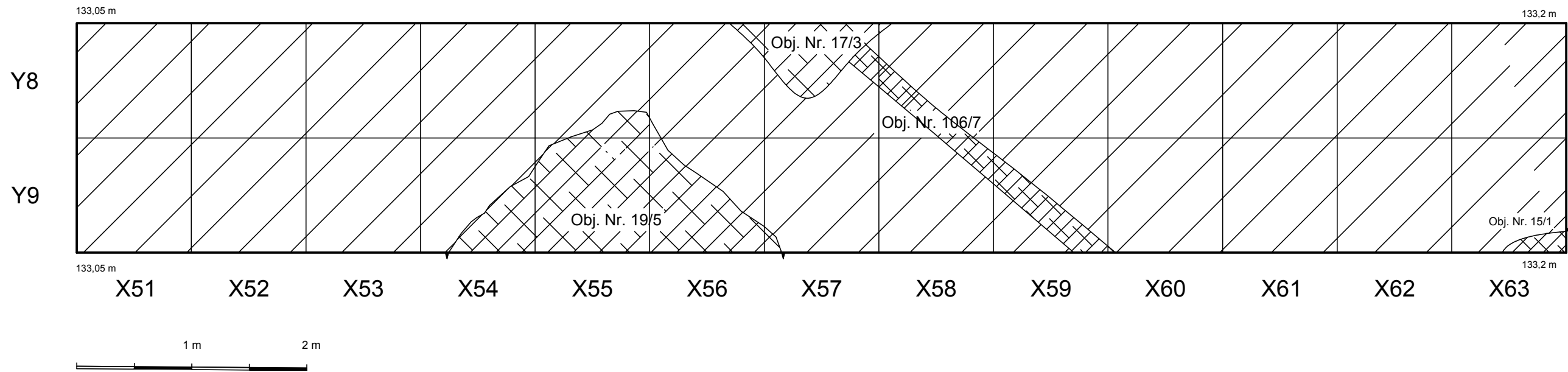

P-3 obj. sit. planas įžemyje (0,4 m gylis)

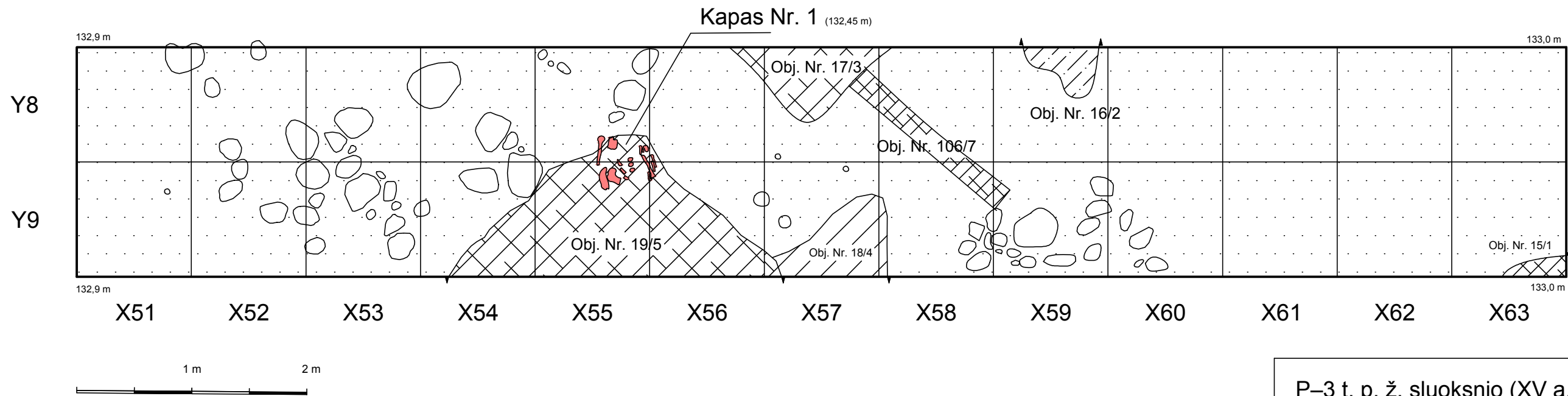

P-3 t. p. ž. sluoksni (XV a.) sit. planas (0,3 m gylis); P-3 obj. sit. planas įžemyje (0,4 m gylis)

M1:40

Brėžinys Nr. 12



P-4 sit. planas (0,2 m gylis)

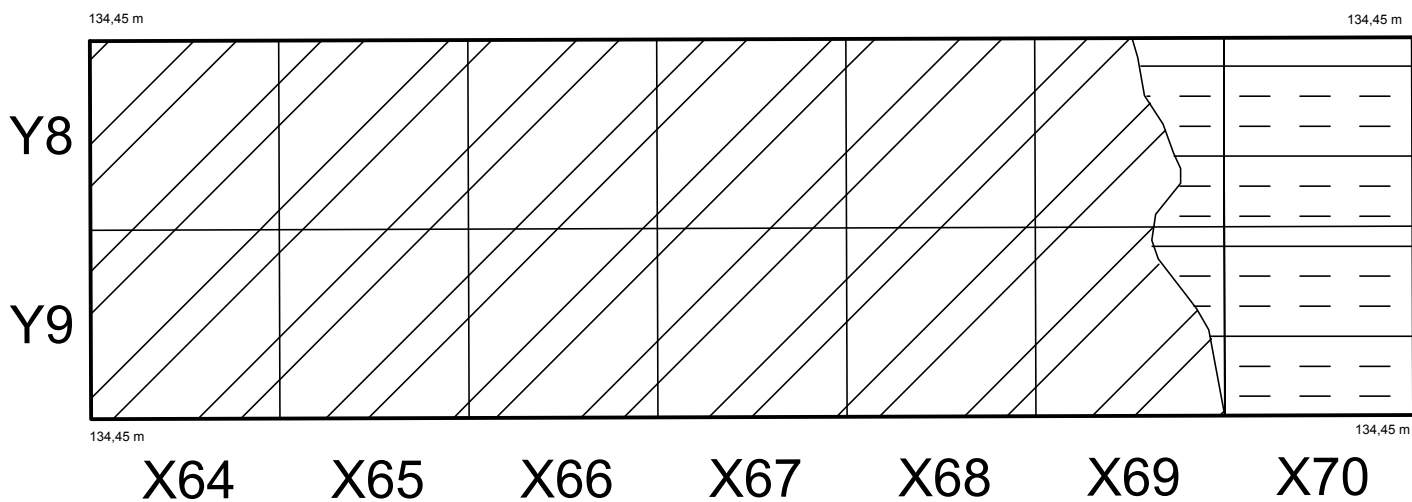

P-4 aptiktų puodų sit. planas (1,1–1,4 m gylis)

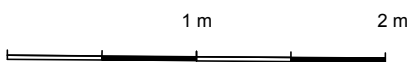
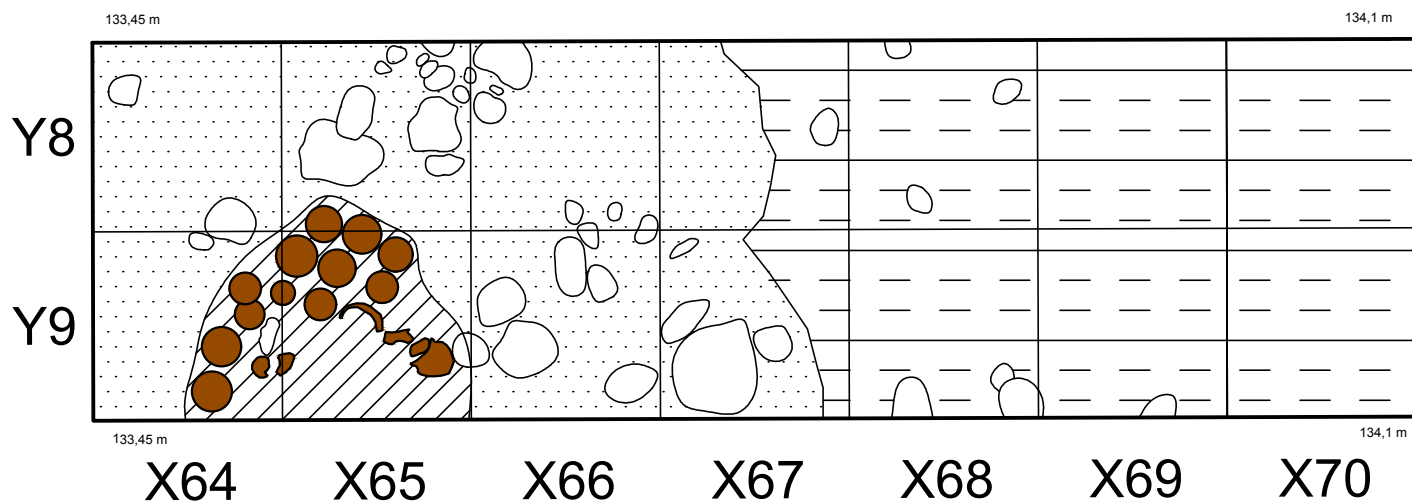

P-4 sit. planas (0,2 m gylis);  
P-4 aptiktų puodų sit. planas (1,1–1,4 m gylis)

M1:40

Brėžinys Nr. 13



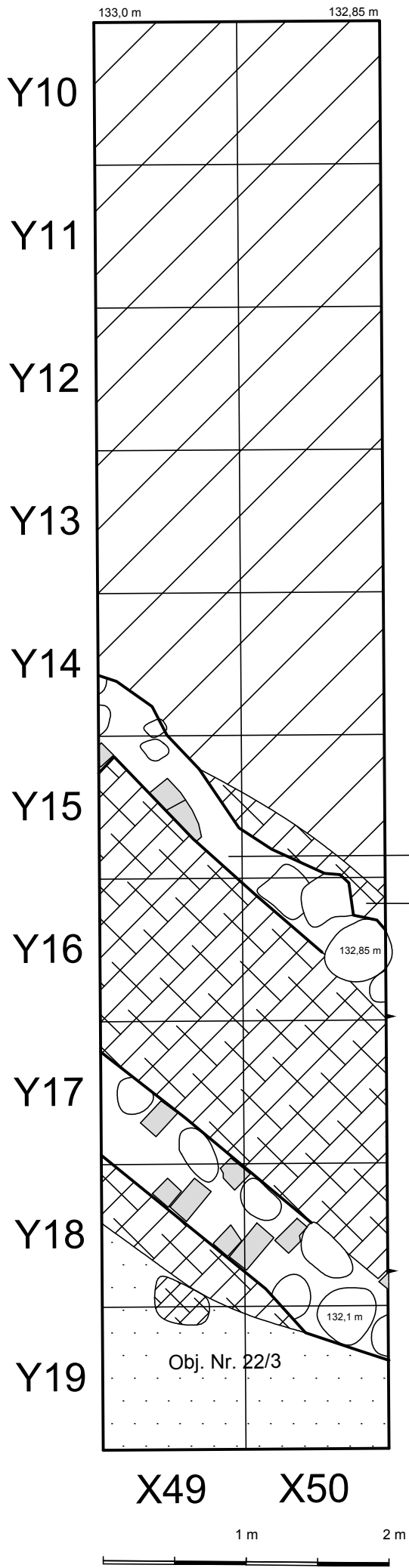

Krosnies  
Nr. K1 fragm.

Pamato duobė

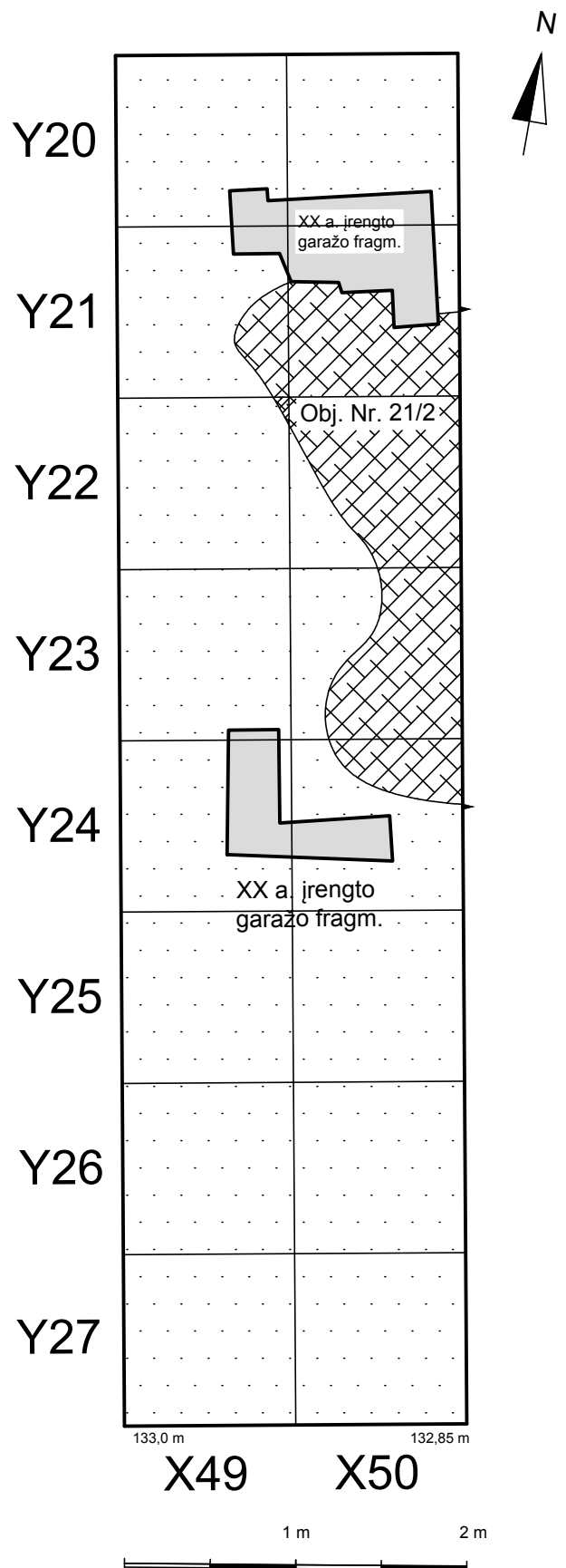

P-5 t. p. ž. sluoksniu (XV a.) sit. planas  
(0,1-0,2 m gyliš)

M1:40

Brėžinys Nr. 14

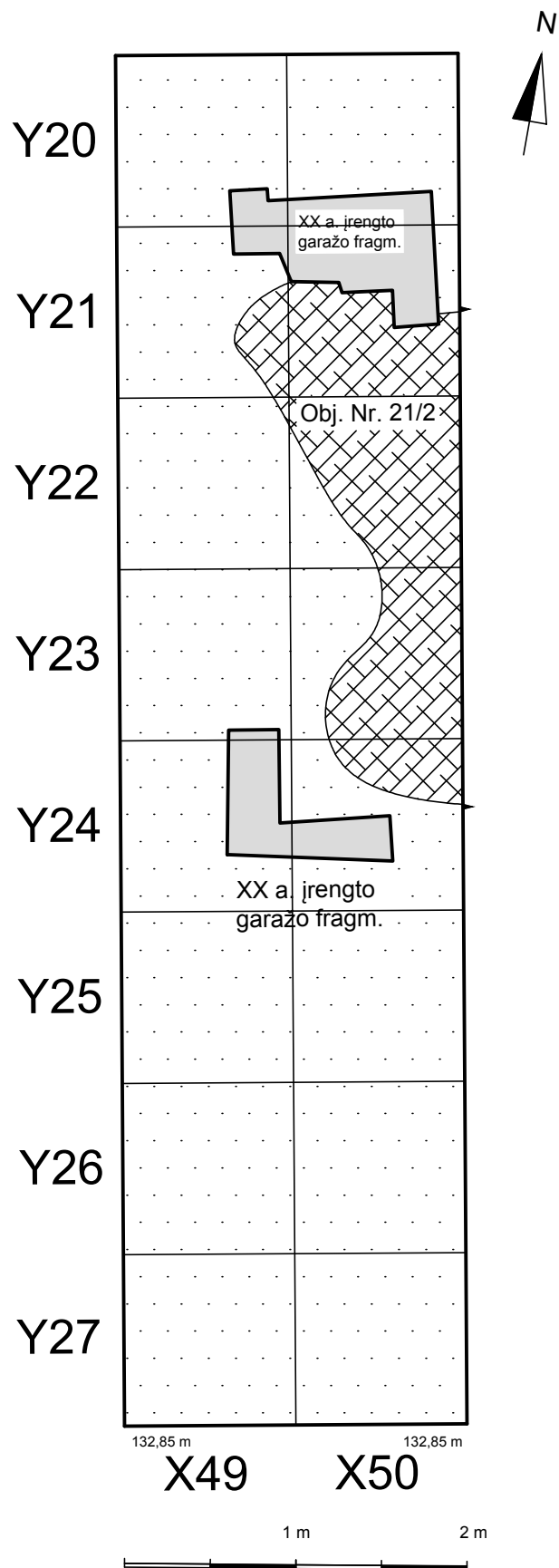
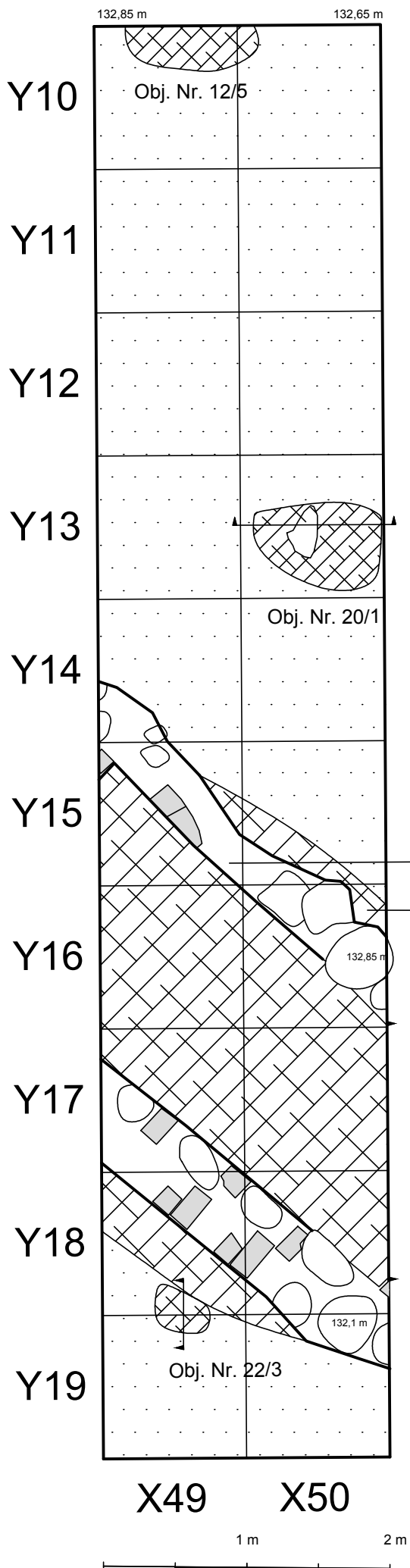

P-5 obj. sit. planas įžemyje (0,2–0,4 m gylis)

M1:40

Brėžinys Nr. 15

### Obj. Nr. 20/1

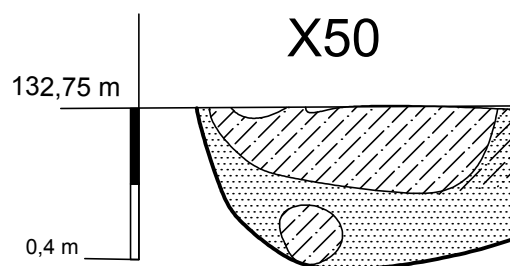

### Obj. Nr. 22/3

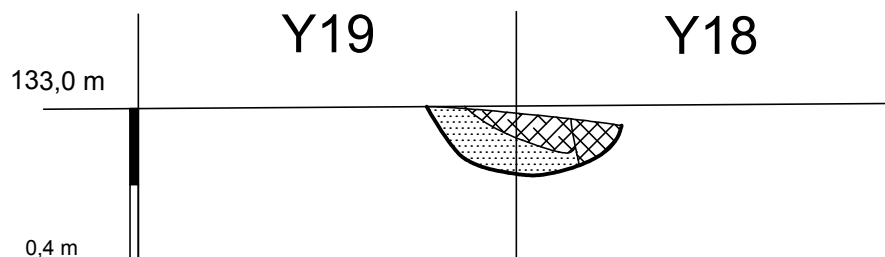

### Obj. Nr. 24/1

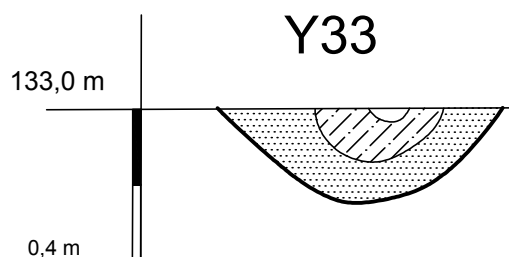

Obj. Nr. 20/1, 22/3, 24/1

M1:20

Brėžinys Nr. 16

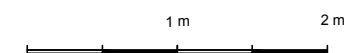
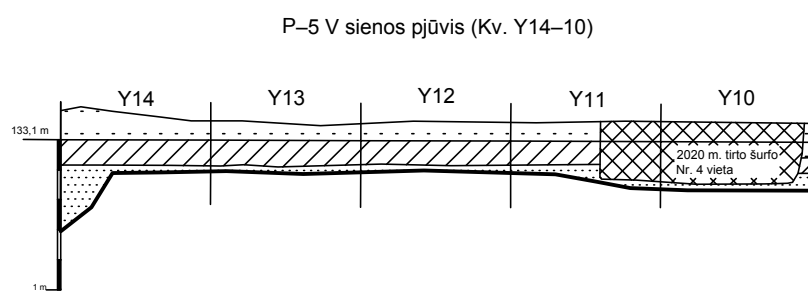
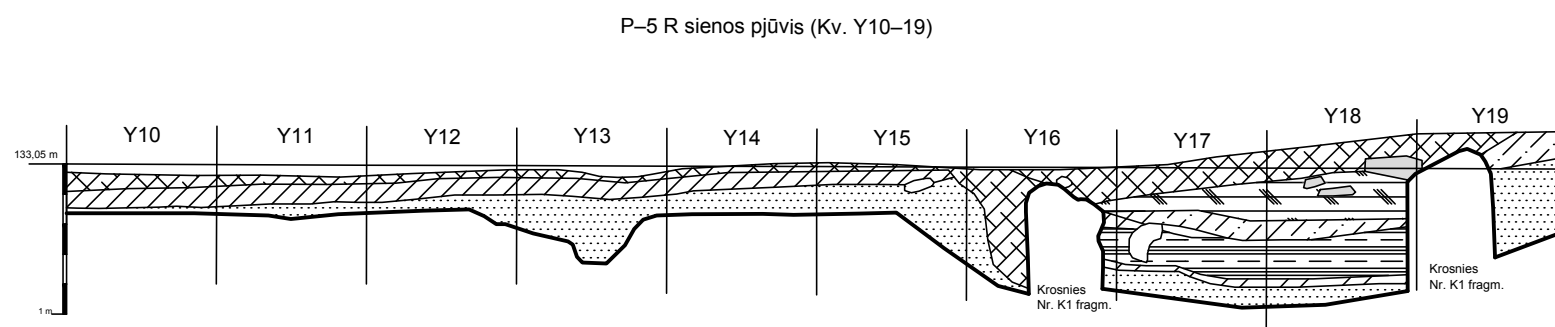
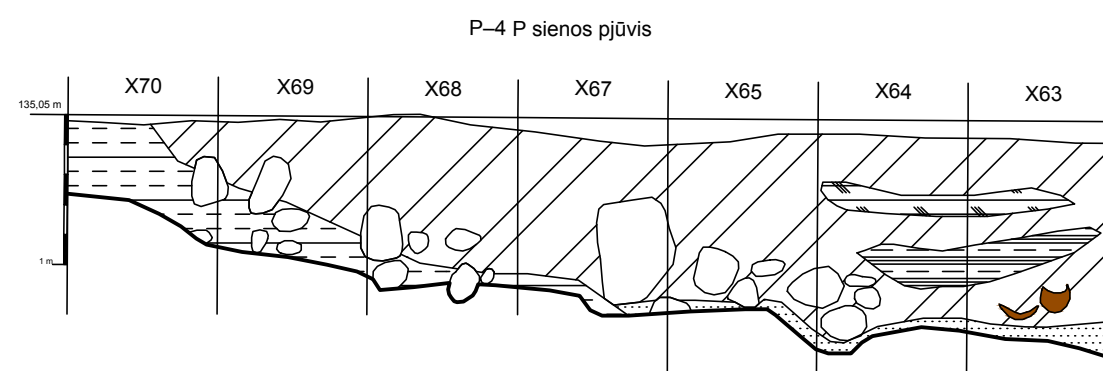
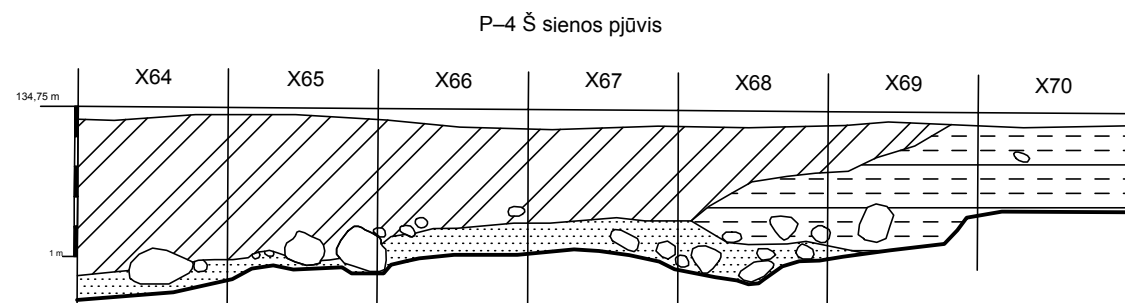
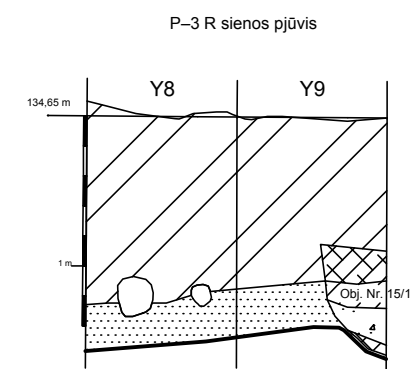
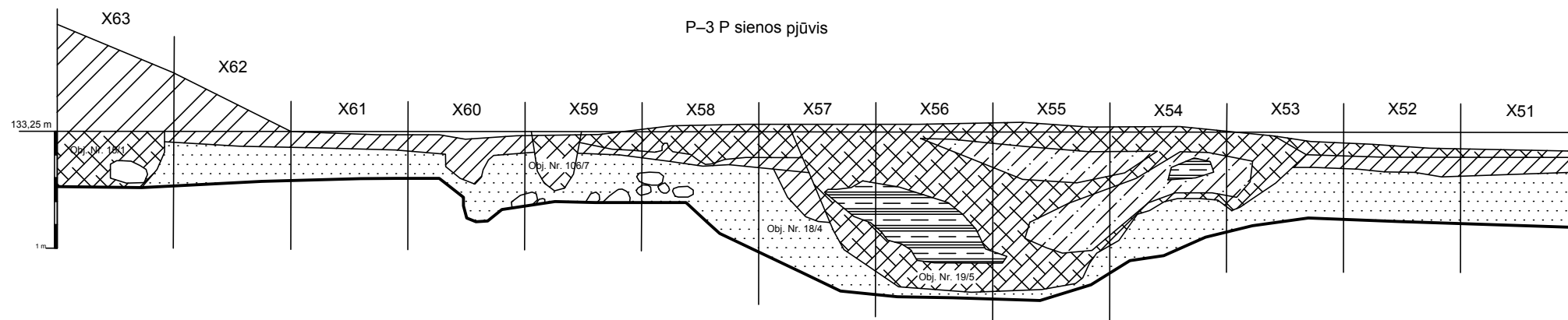

P-3, R, P sienų pjūviai; P-4, Š, P sienų pjūviai;  
P-5 R sienos pjūvis (Kv. Y10–Y19);  
P-5 V sienos pjūvis (Kv. Y14–10)

M1:40

Brėžinys Nr. 17

P-6 obj. sit. planas įžemyje

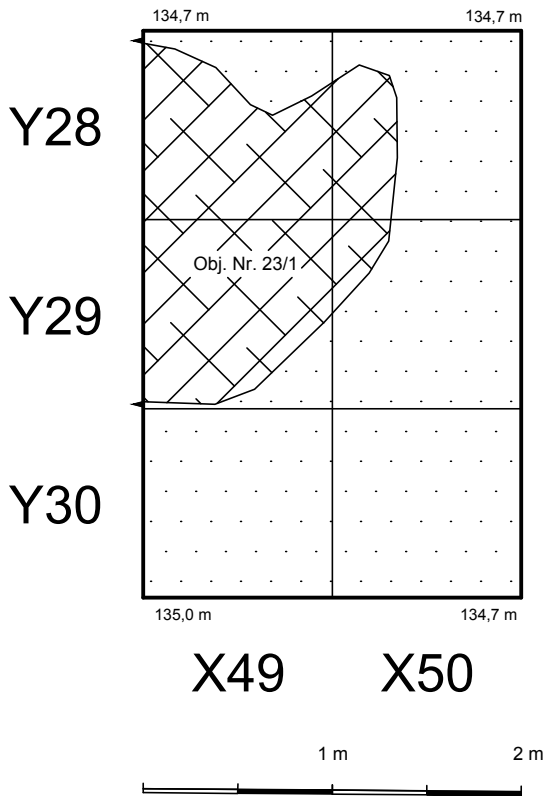

P-6 R sienos pjūvis (Kv. X28)

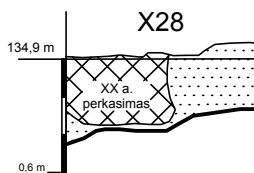

P-6 V sienų pjūvis

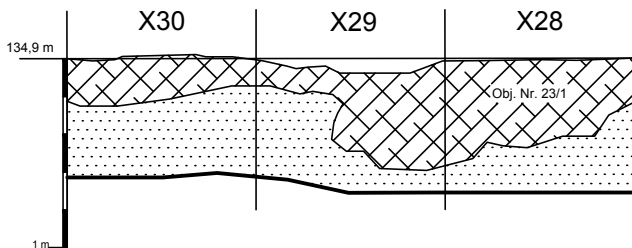

P-7 sit. planas 0,6–0,8 m gilyje

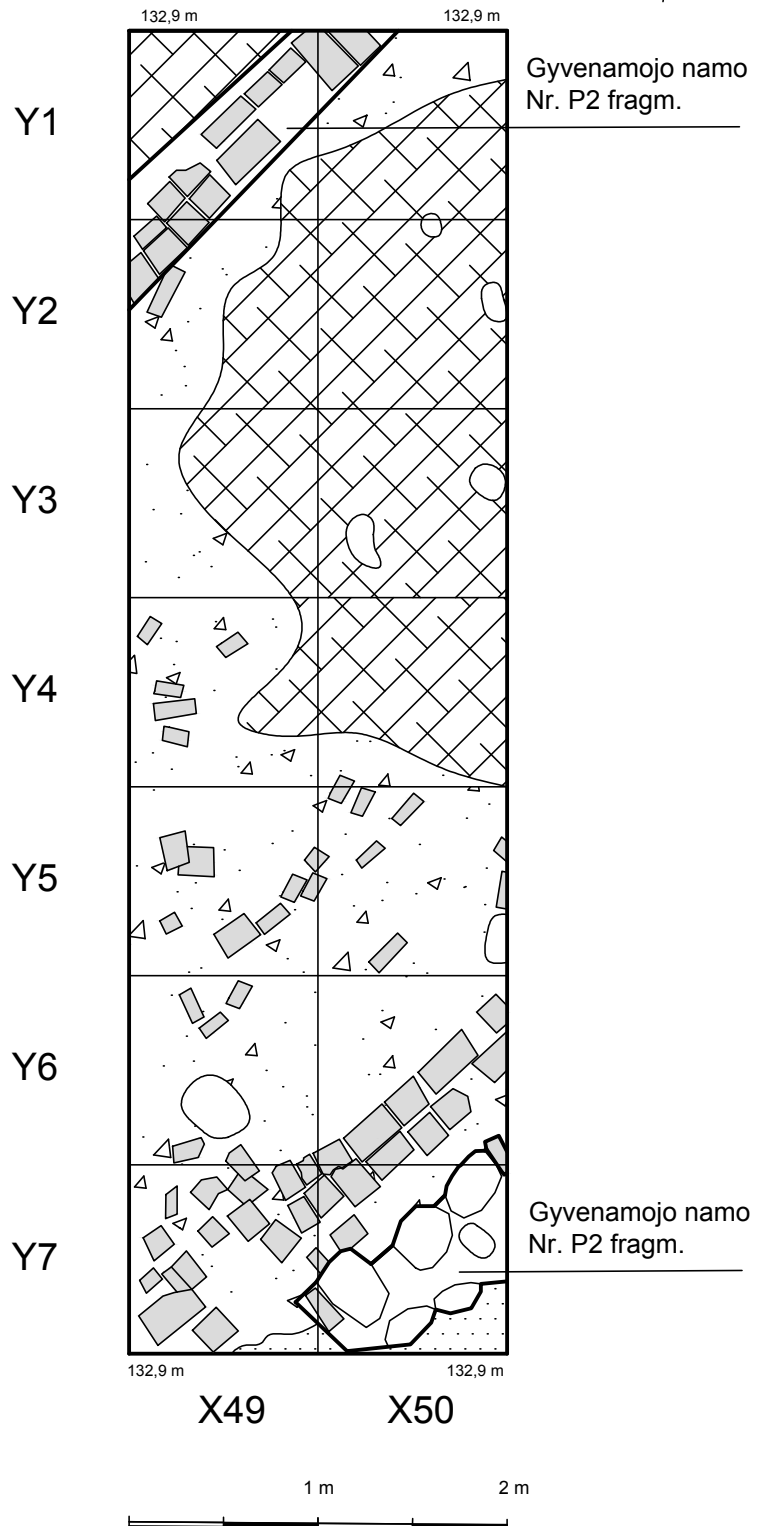

P-6 obj. sit. planas įžemyje (0,4 m gylis);  
 P-6 R (Kv. X28), V sienų pjūviai;  
 P-7 sit. planas (0,6–0,8 m gylis)

M1:40

Brėžinys Nr. 18



P-8 sit. planas t. p. ž. (XV a.) sluoksnyje  
(0,3–0,35 m gylis)

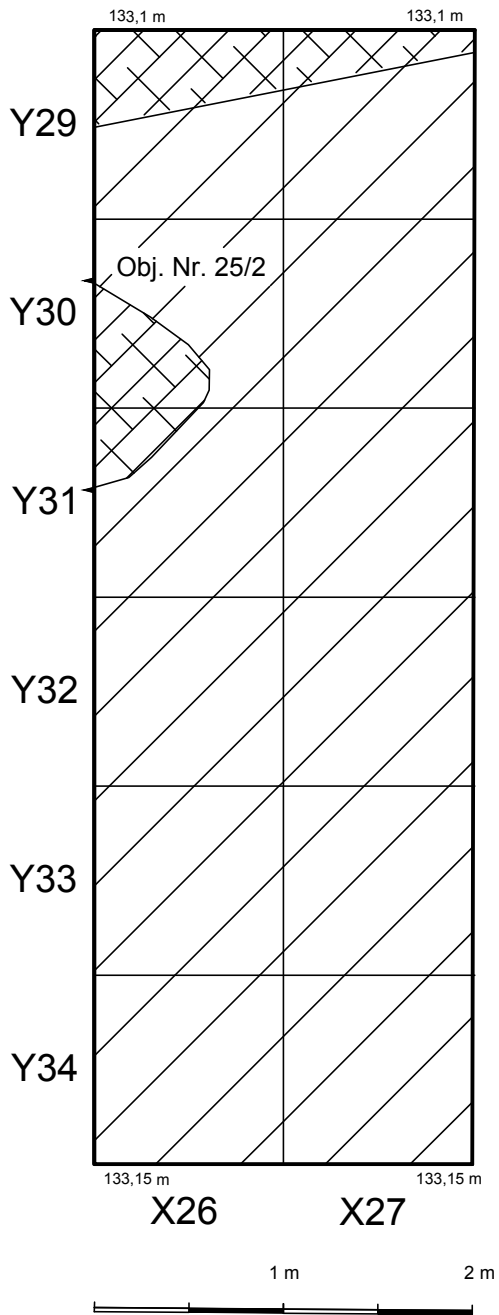

P-8 – obj. sit. planas įžemyje

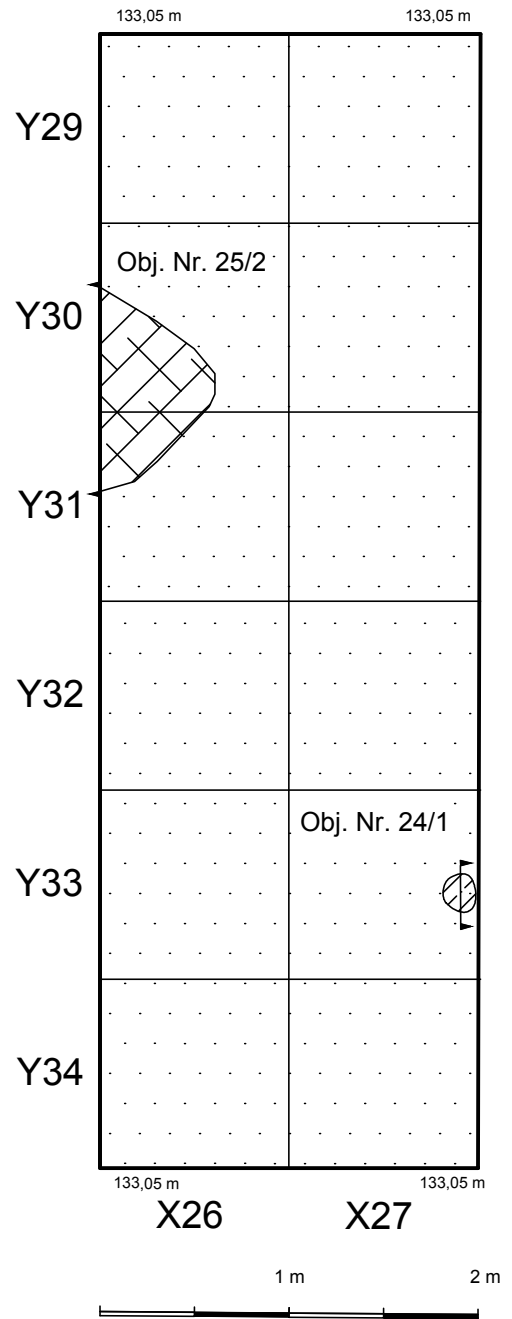

P-8 t. p. ž. sluoksnių (XV a.) sit. planas (0,3–0,35 m gylis); P-8 obj. sit. planas įžemyje (0,4–0,45 m gylis)

M1:40

Brėžinys Nr. 19

P-7 R sienos pjūvis

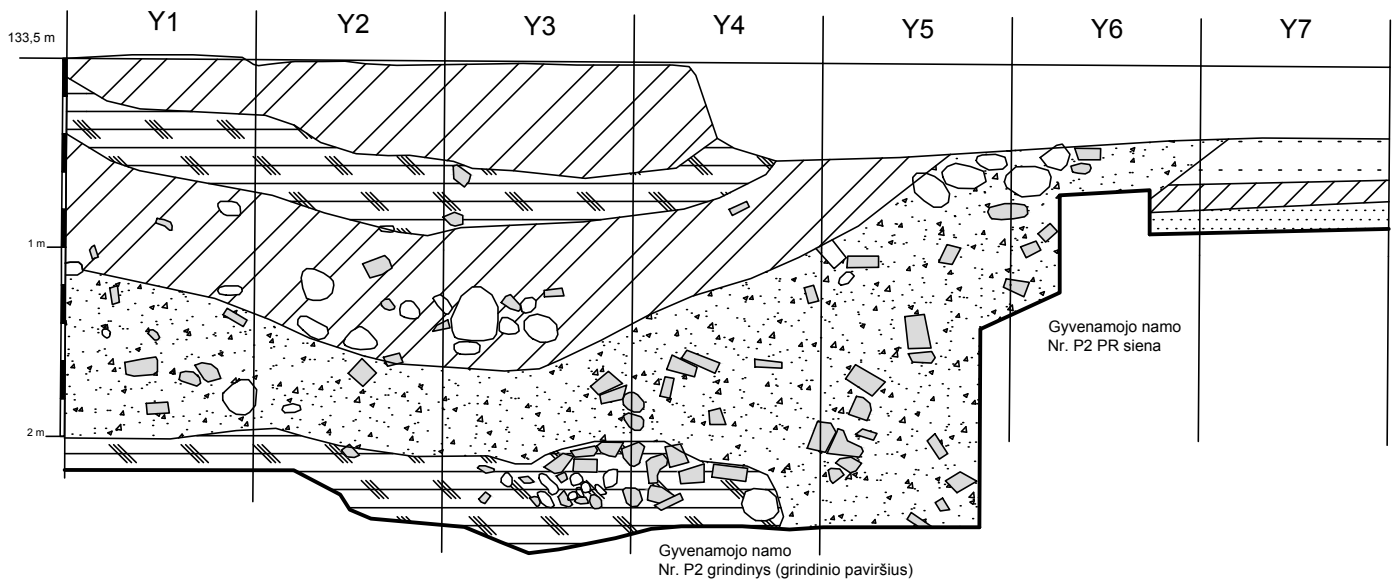

P-8 R sienos pjūvis

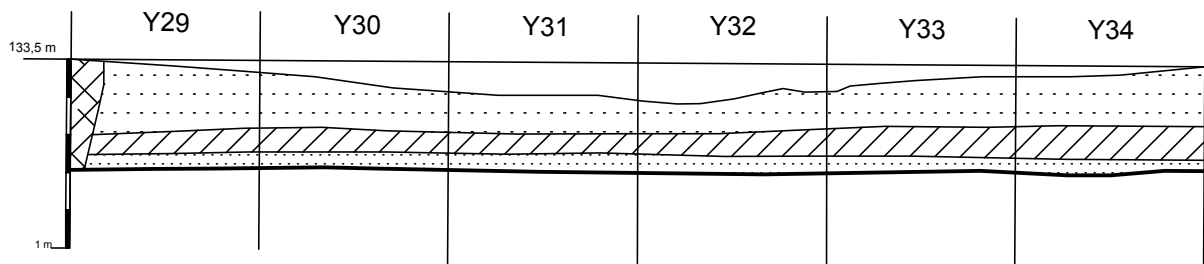

P-8 V sienos pjūvis

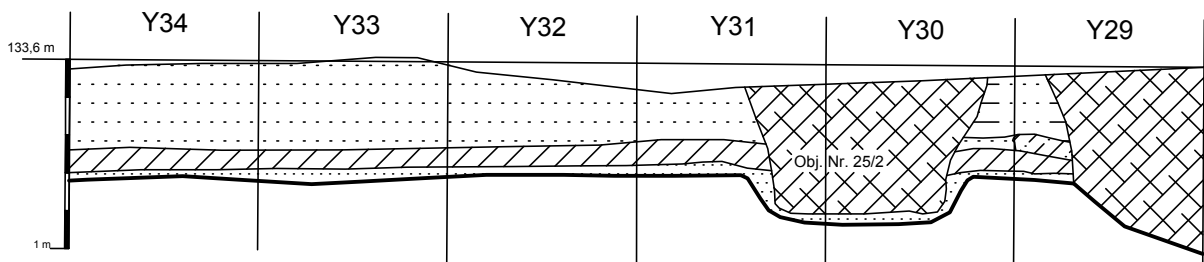

1 m 2 m



P-8 P sienos pjūvis

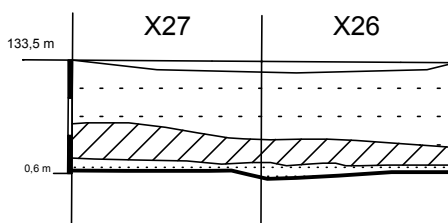

P-7 R sienos pjūvis; P-8 R, P, V sienų pjūviai

M1:40

Brėžinys Nr. 20

P-9 sit. planas (0,2 m gylis)

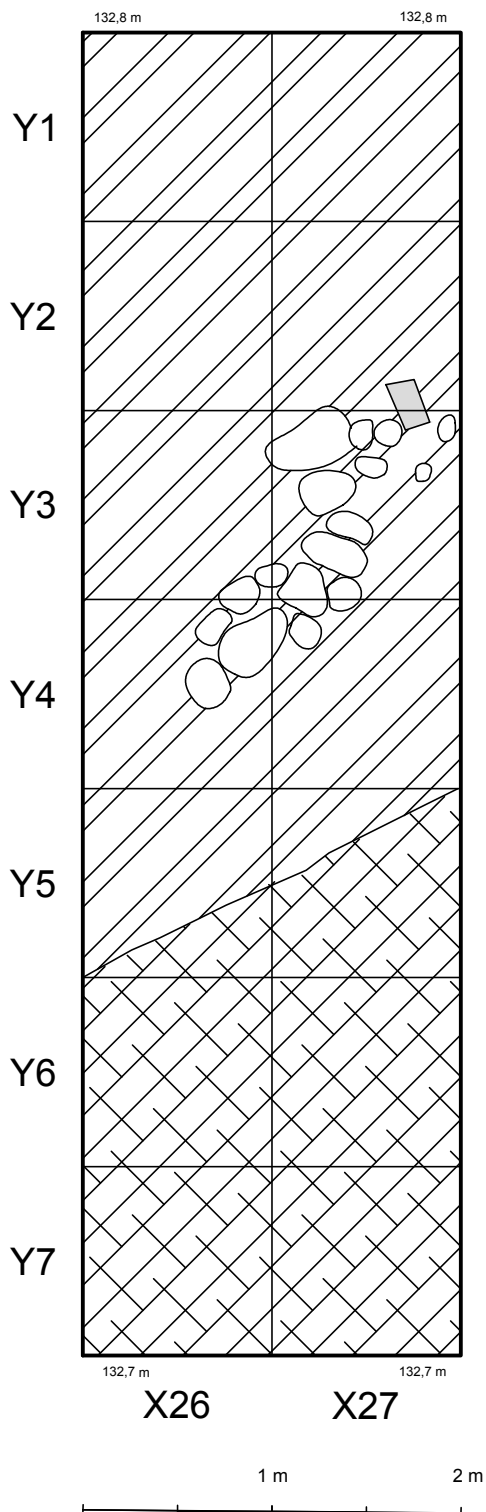

P-9 sit. planas (0,6 m gylis)

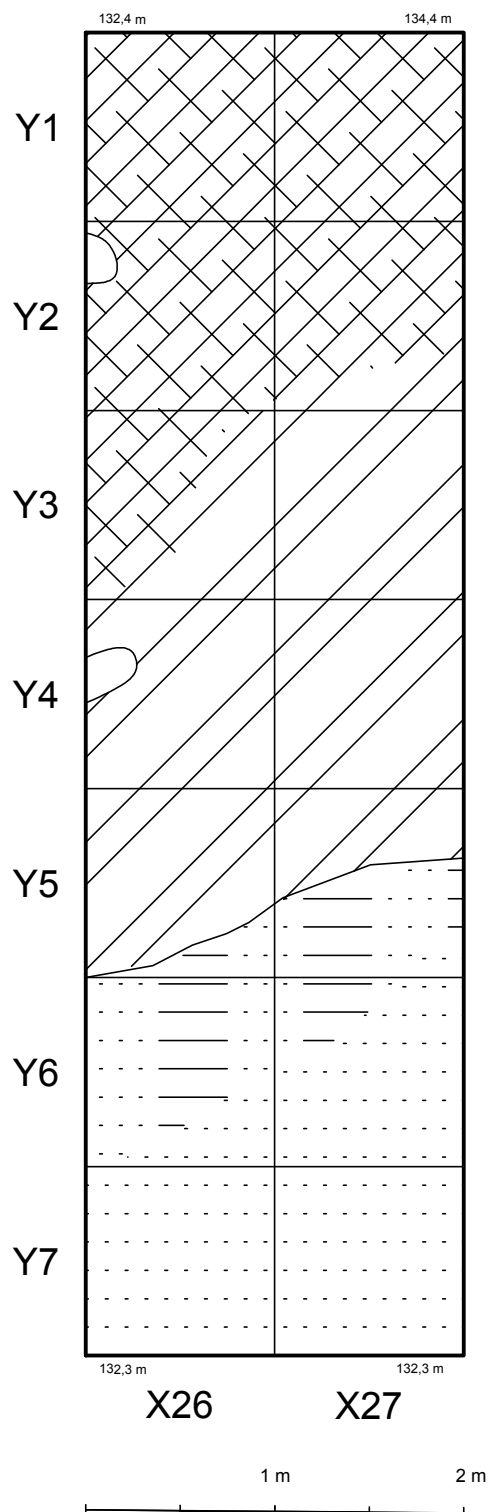

P-9 sit. planas (0,2 m gylis);  
P-9 sit. planas (0,6 m gylis)

M1:40

Brėžinys Nr. 21



P-9 sit. planas t. p. ž. (XV a.) sluoksnyje  
(1–1,3 m gylis)

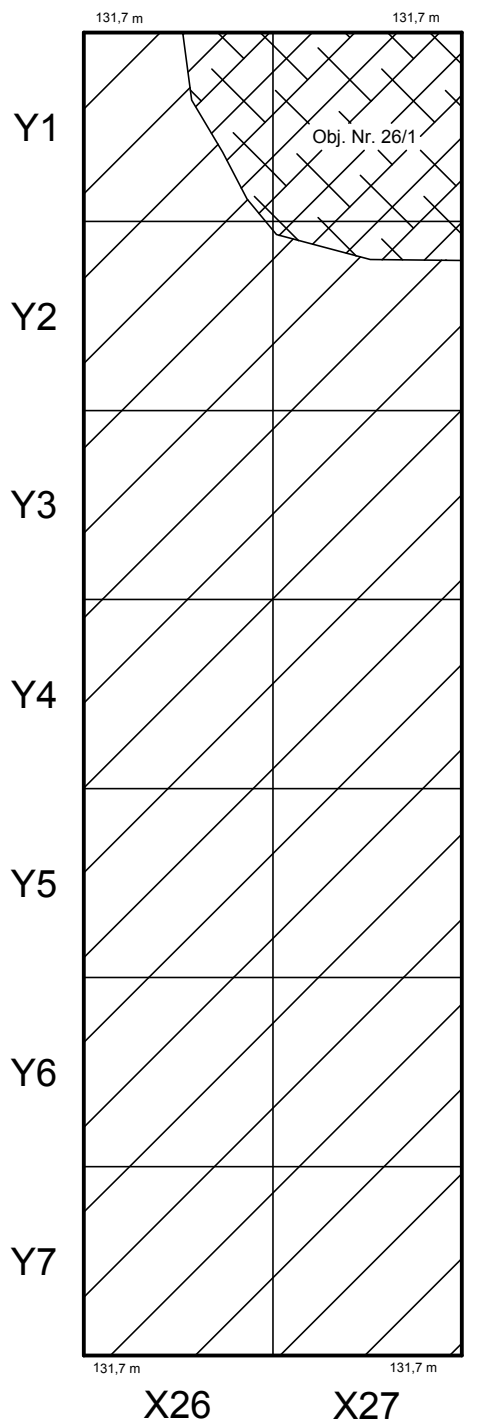

P-9 obj. sit. planas  
įžemyje (1,2–1,45 m gylis)

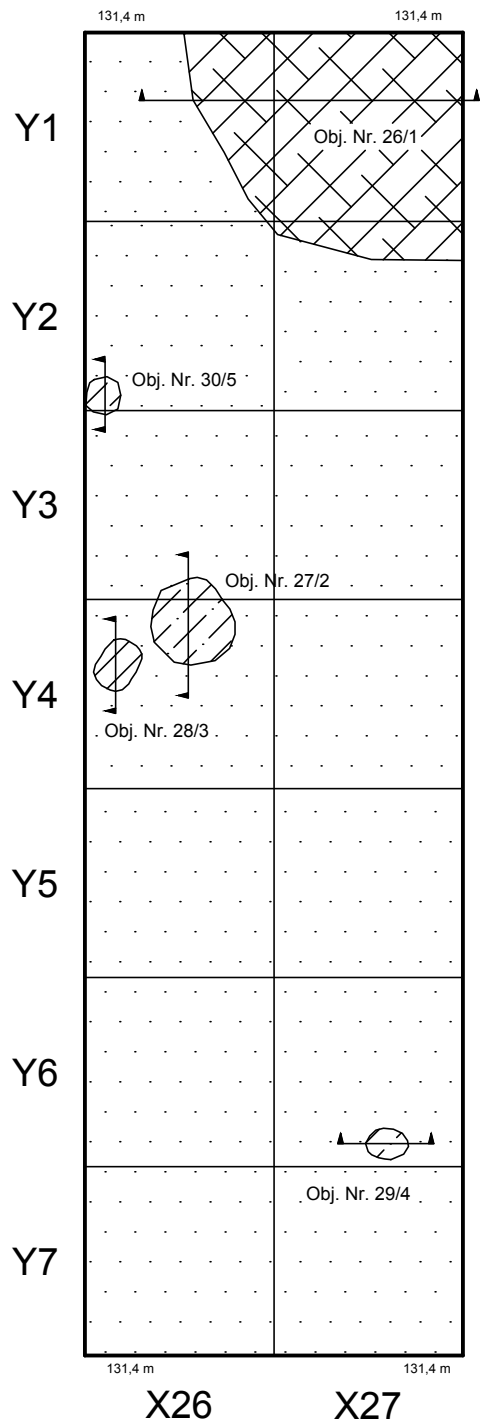

P-9 t. p. ž. sluoksniu (XV a.) sit. planas (1–1,3 m  
gylis); P-9 obj. sit. planas įžemyje  
(1,2–1,45 m gylis)

M1:40

Brėžinys Nr. 22

# Obj. Nr. 27/2

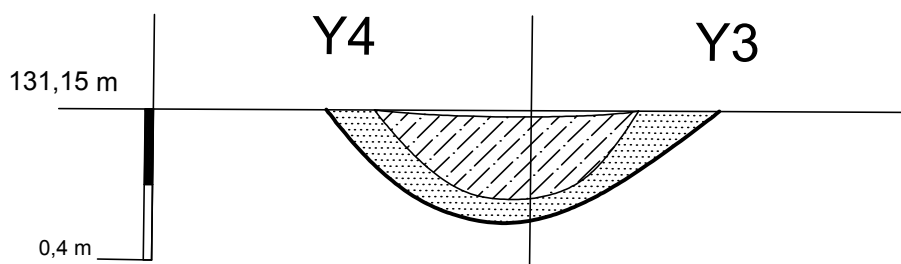

# Obj. Nr. 28/3

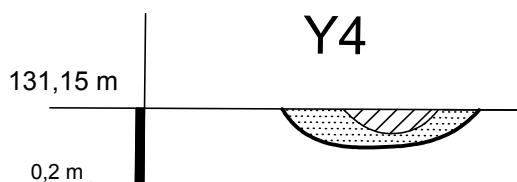

# Obj. Nr. 29/4

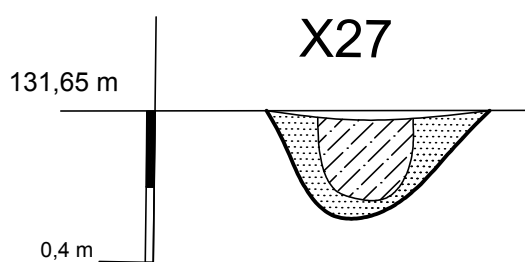

Obj. Nr. 27/2–29/4

M1:20

Brėžinys Nr. 23

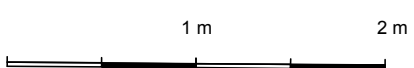
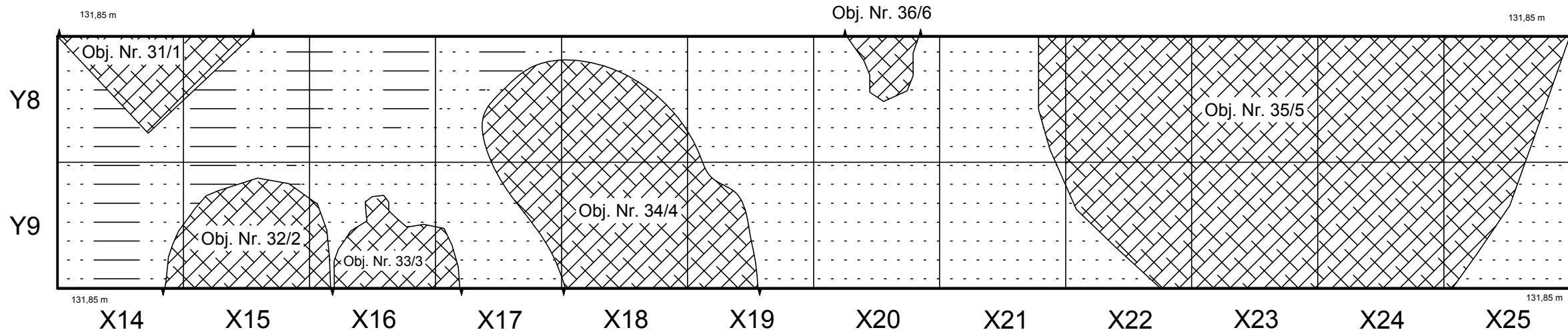
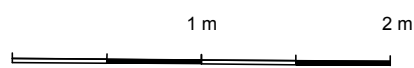
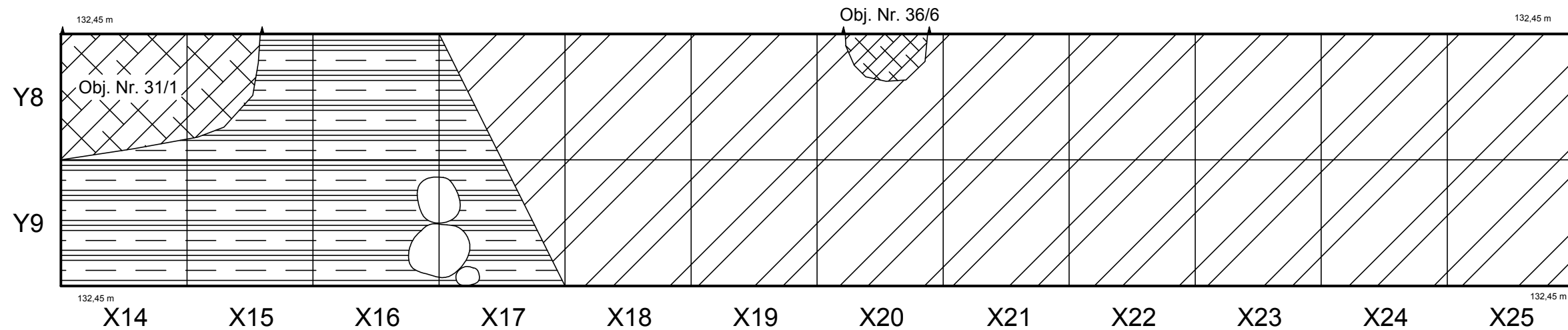

P-10 sit. planas (0,2 m gylis); P-10 sit. planas (0,8 m gylis)
M1:40
Brėžinys Nr. 24

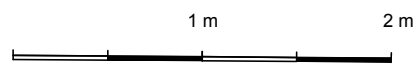
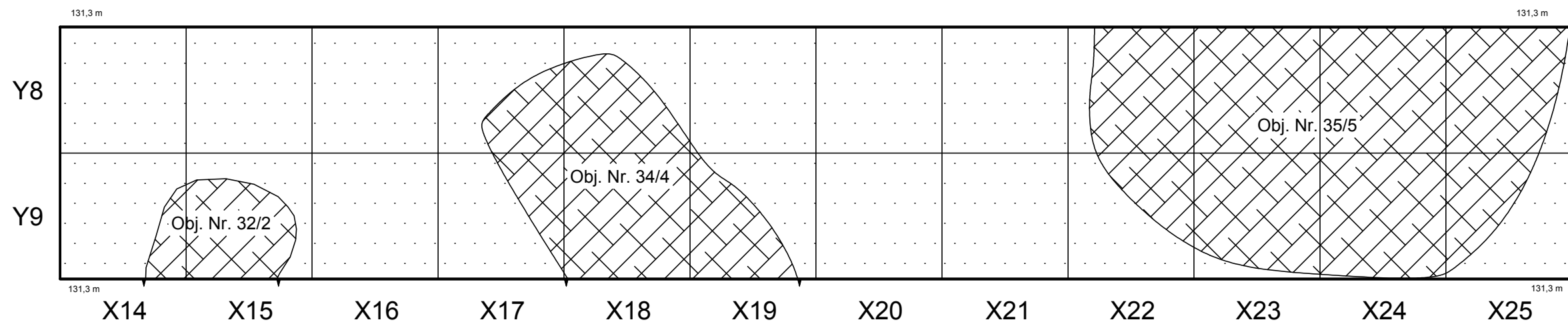
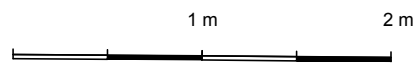
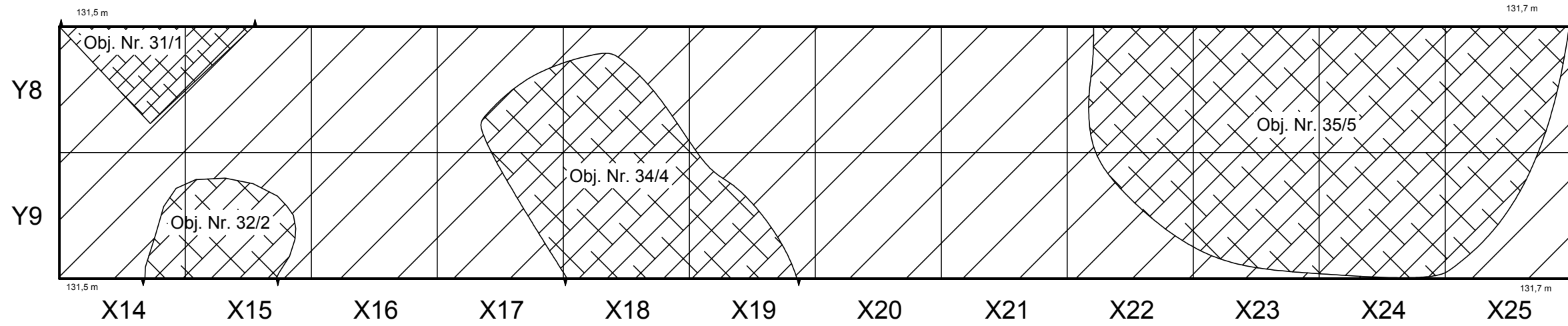

P-10 t. p. ž. sluoksniu (XV a.) sit. planas (1,2 m gylis); P-10 obj. sit. planas įžemyje (1,3–1,35 m gylis)

M1:40

Brėžinys Nr. 25



### Obj. Nr. 35/5 planas

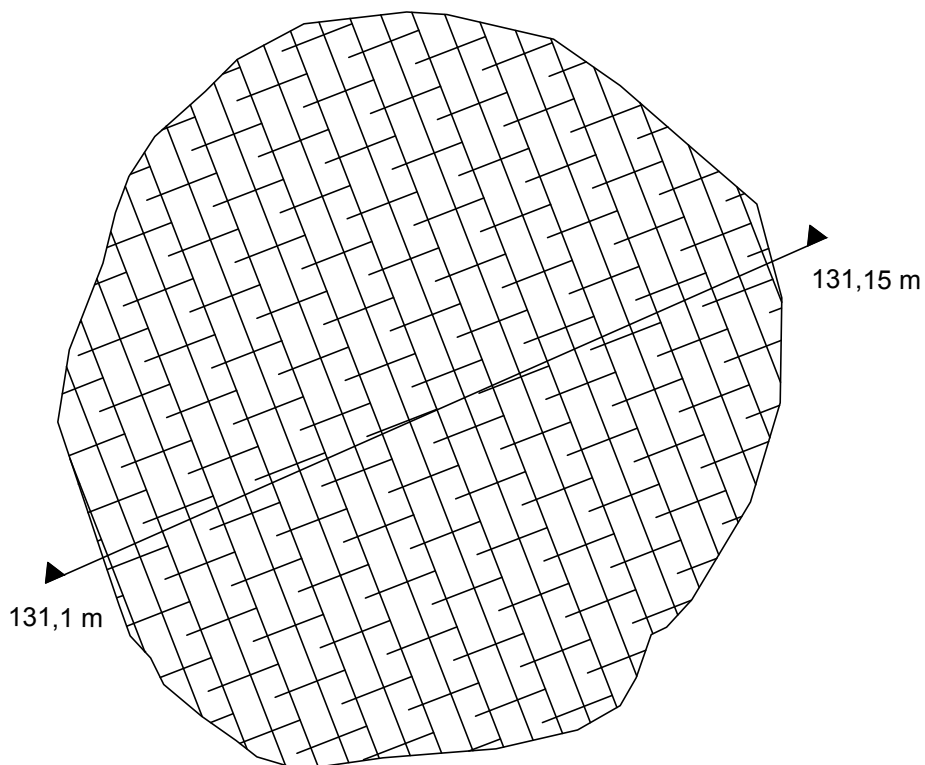

### Obj. Nr. 35/5 viršutinė pjūvio dalis

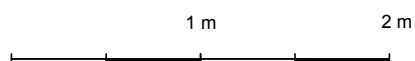
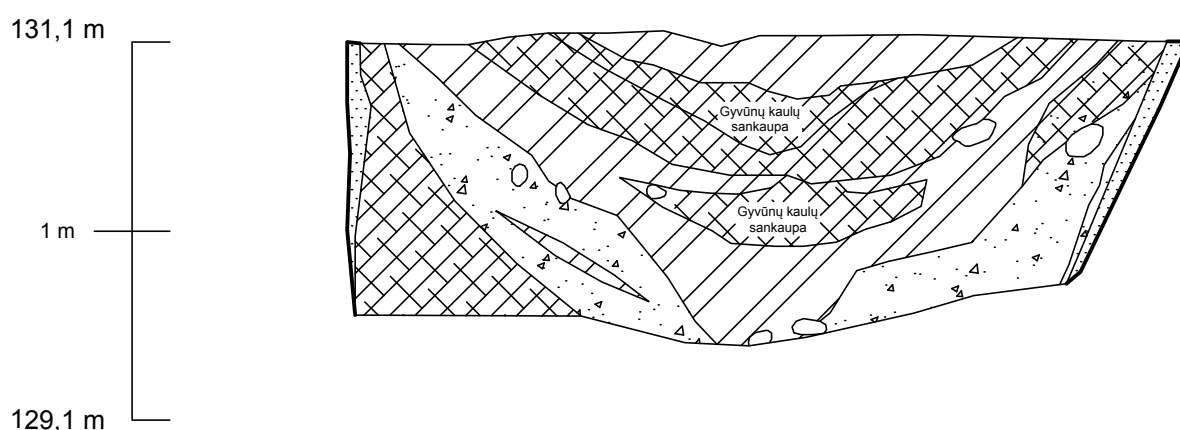

Obj. Nr. 35/5 planas;  
Obj. Nr. 35/5 viršutinė pjūvio dalis

M1:40

Brėžinys Nr. 26

Obj. Nr. 35/5 planas (aptikus medinį kontūrą)

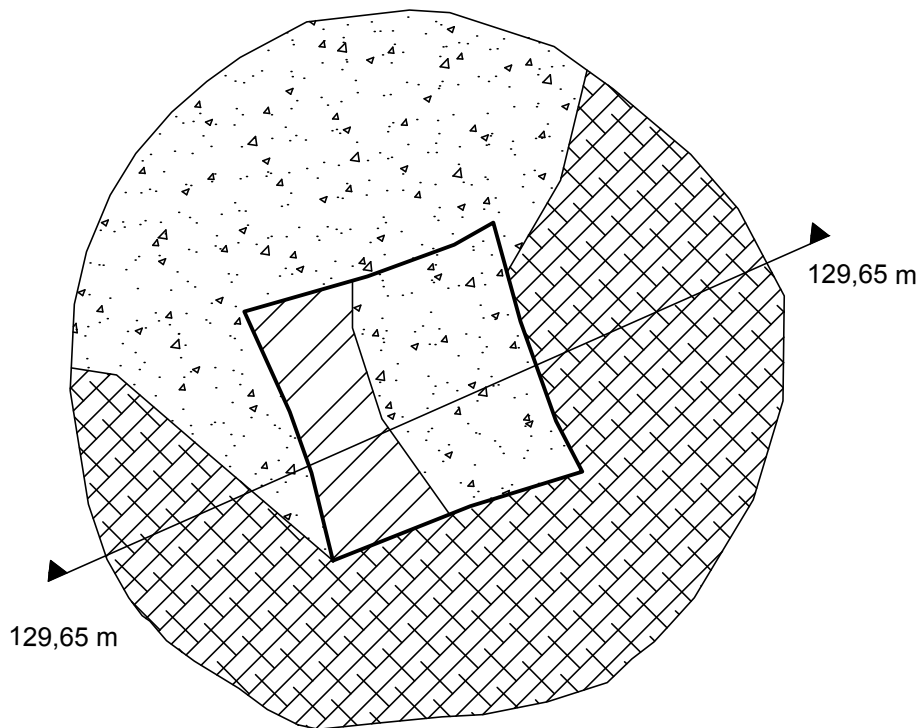

Obj. Nr. 35/5 pjūvis

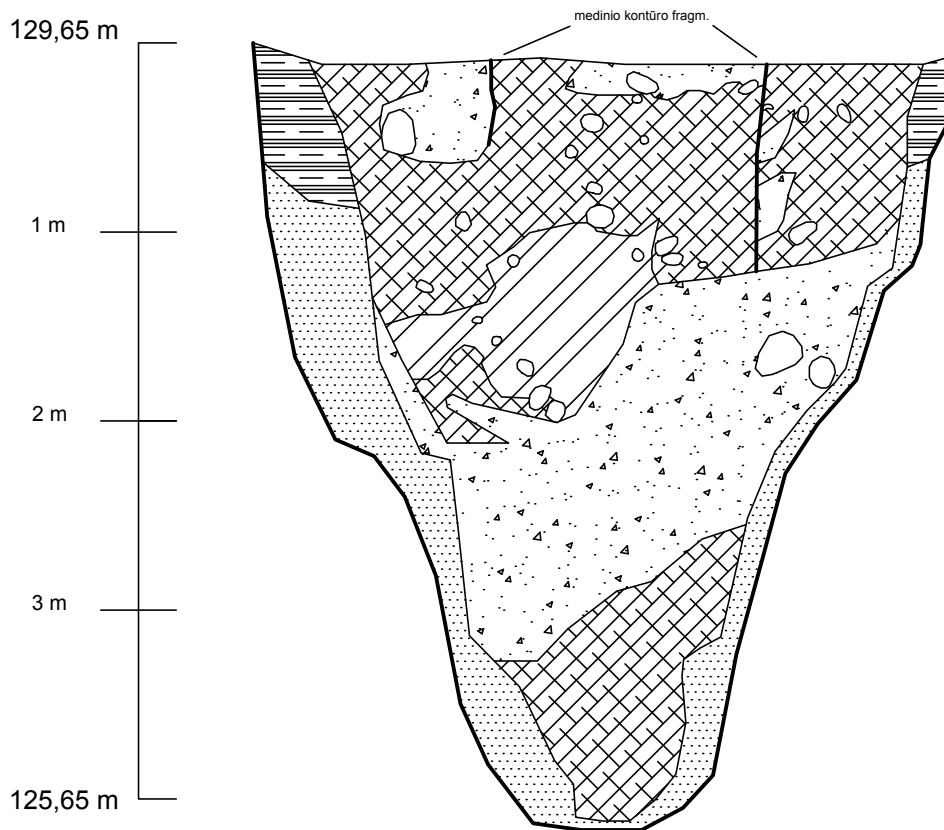

Obj. Nr. 35/5 planas (aptikus medinį kontūrą);  
Obj. Nr. 35/5 pjūvis

M1:40

Brėžinys Nr. 27

P-9 R sienos pjūvis

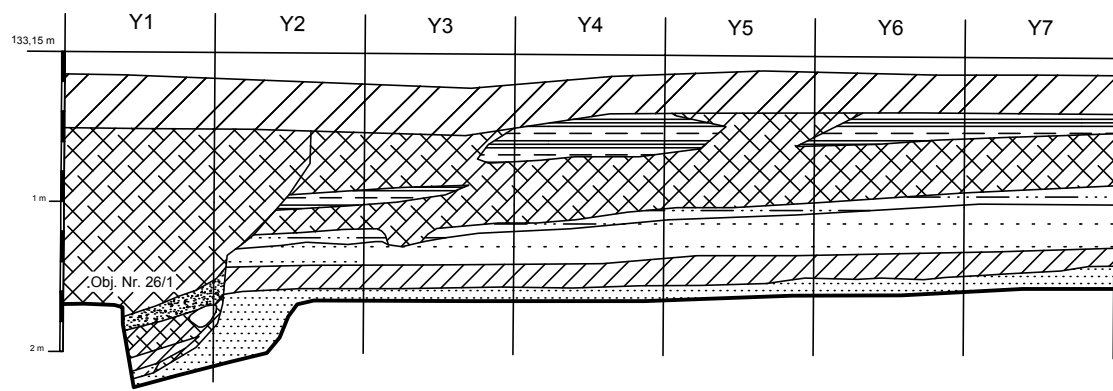

P-9 V sienos pjūvis

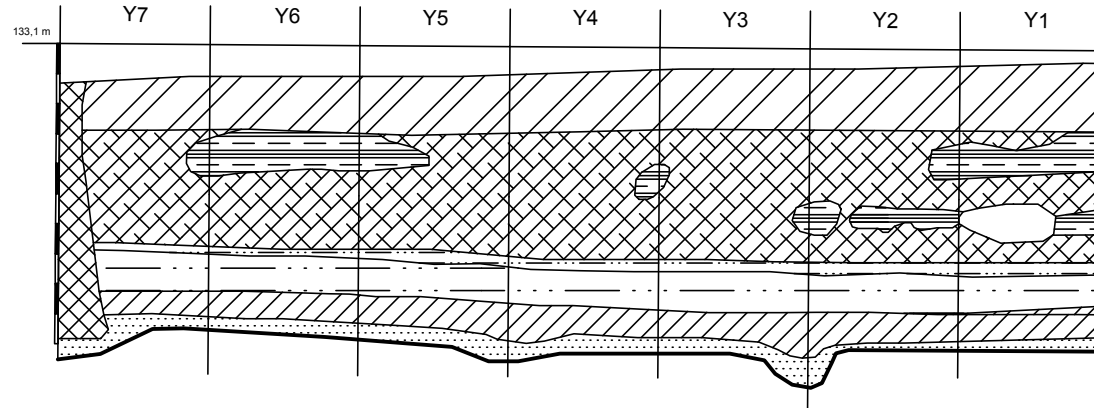

P-9 Š sienos pjūvis

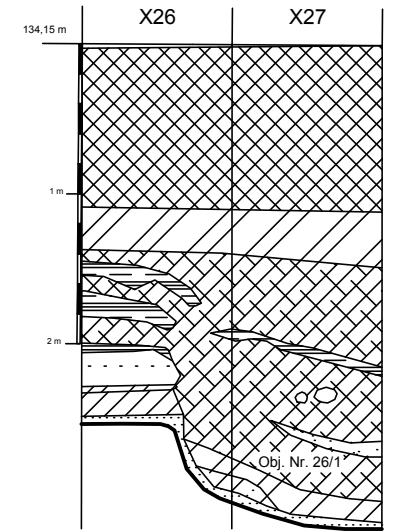

P-10 Š sienos pjūvis

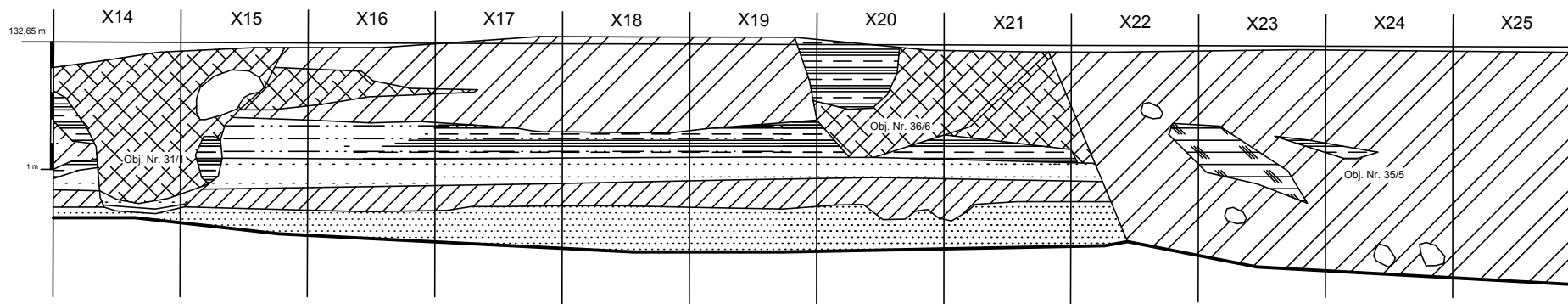

P-10 V sienos pjūvis

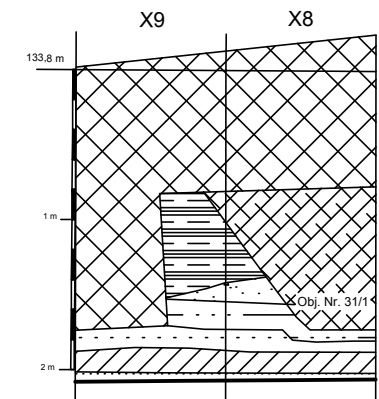

P-10 P sienos pjūvis

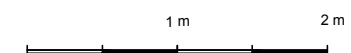
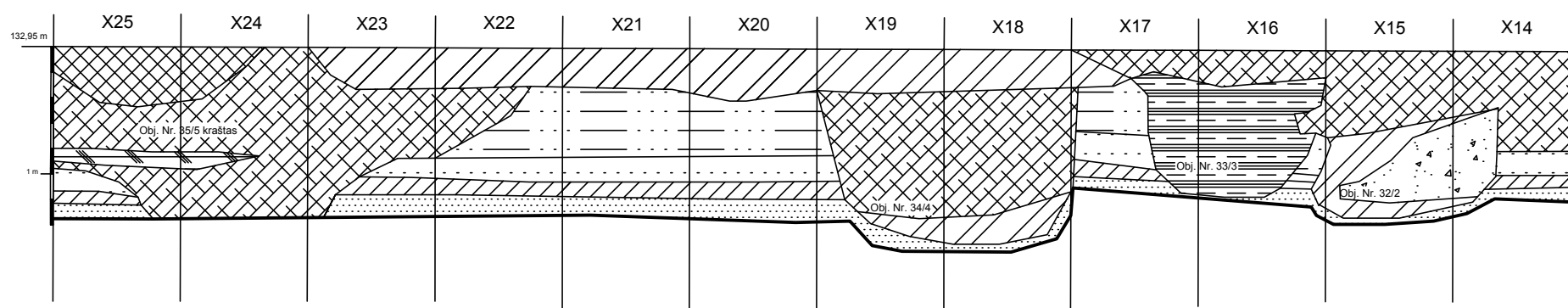

P-9 Š, R, V sienų pjūviai; P-10 Š, P, V sienų pjūviai

M1:40

Brėžinys Nr. 28

132,8 m

132,8 m

Y10

Y11

Y12

Y13

Y14

Y15

Y16

Y17

Y18



132,8 m

X20

X21

X22

X23

X24

X25

132,8 m

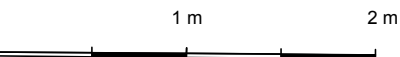

XX a. garažo  
duobės grindys

XX a. garažo  
duobės fragm.

P-11 sit. planas (0,2 m gylis)

M1:40

Brėžinys Nr. 29



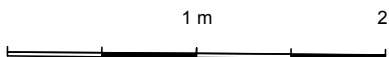

P-11 t. p. ž. sluoksnio (XV a.) sit. planas (1 m gylis)

M1:40

Brėžinys Nr. 30

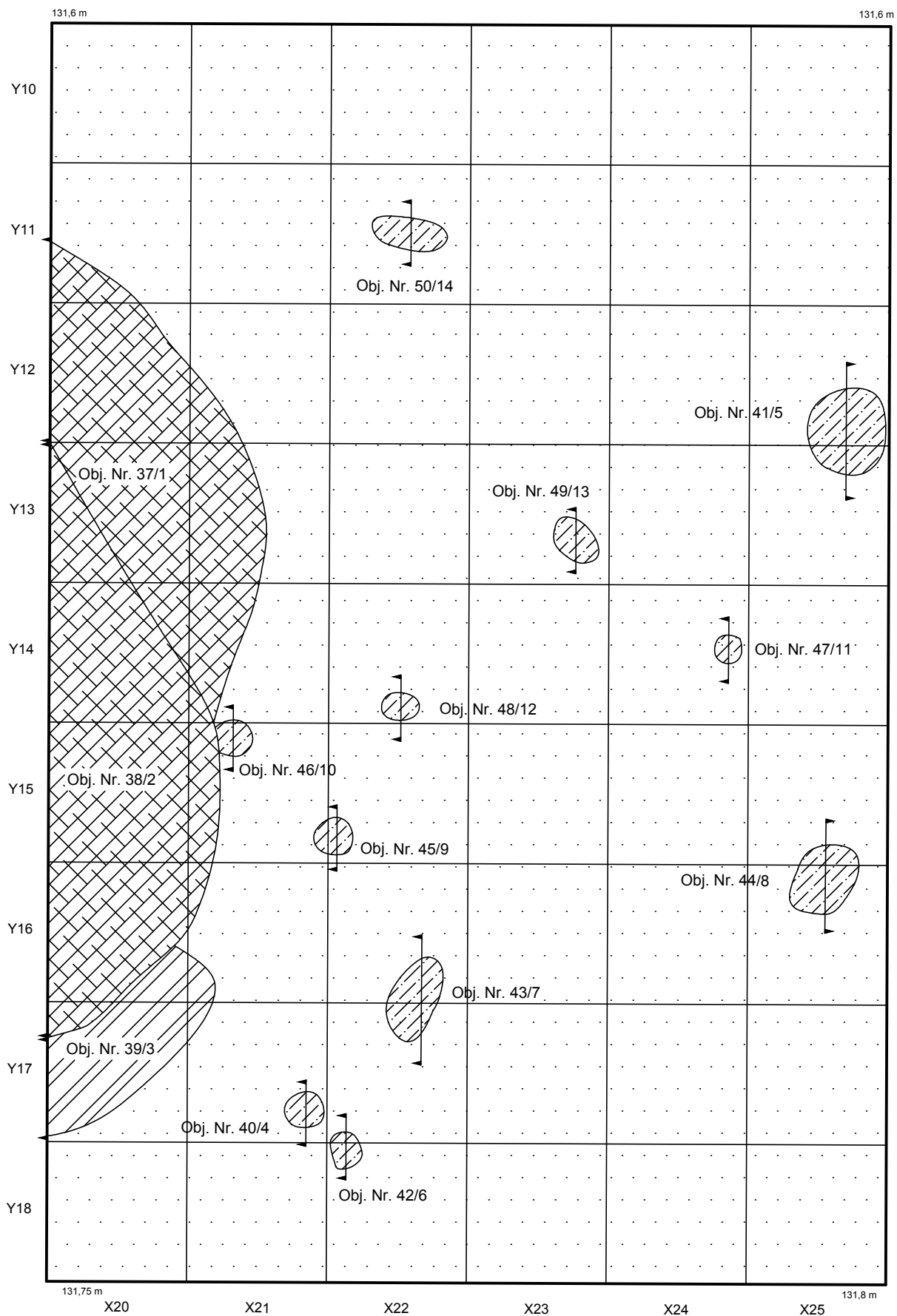

P-11 obj. sit. planas įžemyje (1,15–1,2 m gylis)

M1:40

Brėžinys Nr. 31

Obj. Nr. 40/4

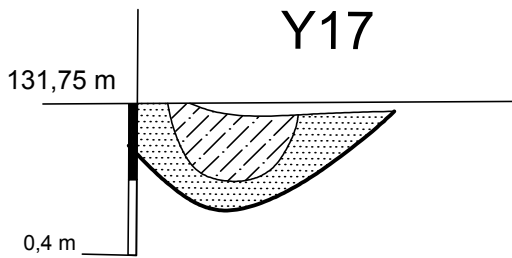

Obj. Nr. 41/5

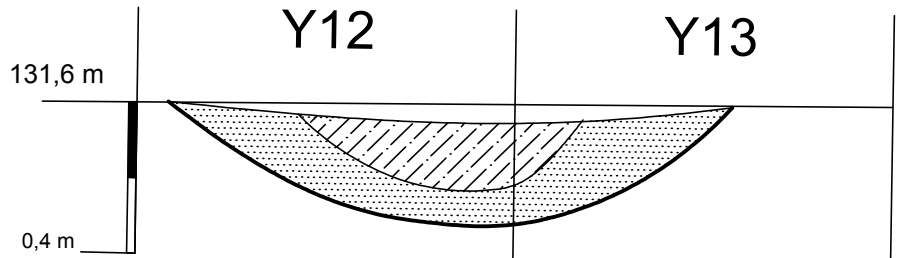

Obj. Nr. 42/6

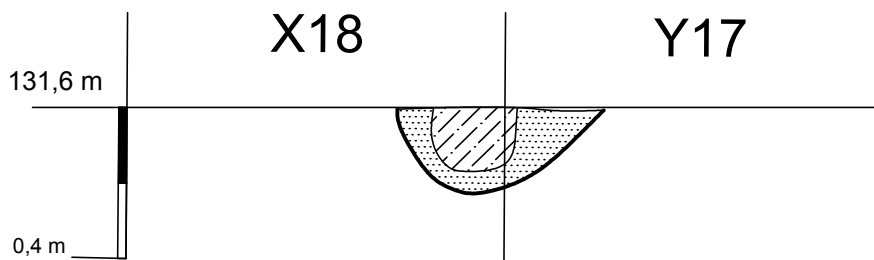

Obj. Nr. 43/7

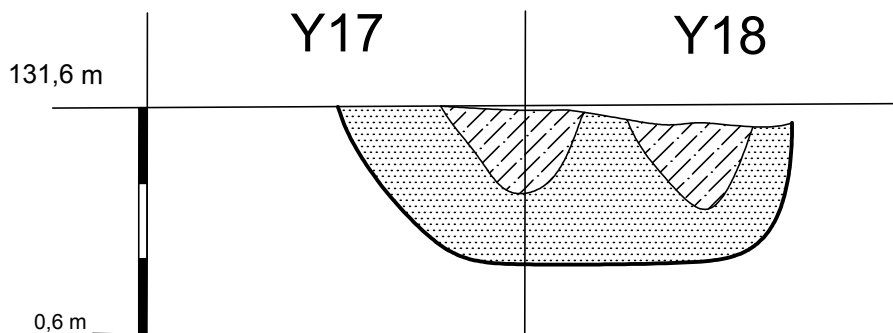

Obj. Nr. 40/4–43/7

M1:20

Brėžinys Nr. 32

Obj. Nr. 44/8

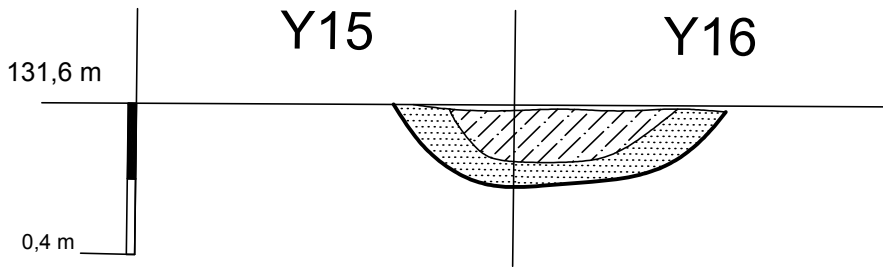

Obj. Nr. 45/9

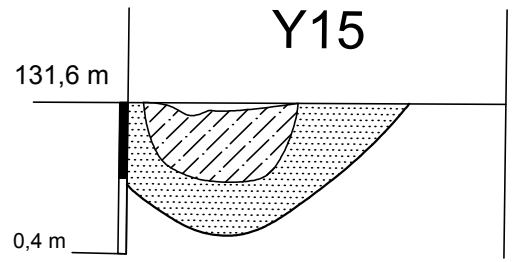

Obj. Nr. 46/10

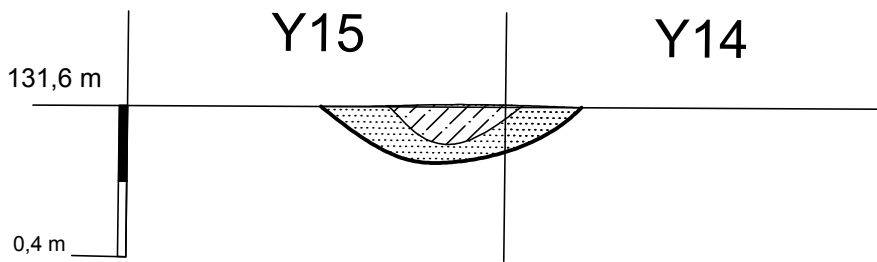

Obj. Nr. 47/11

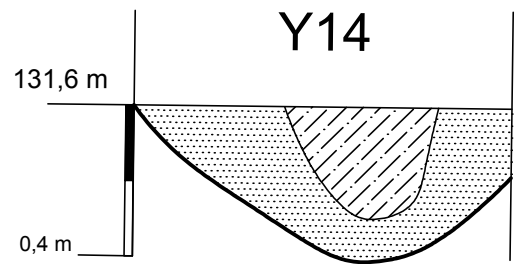

Obj. Nr. 48/12

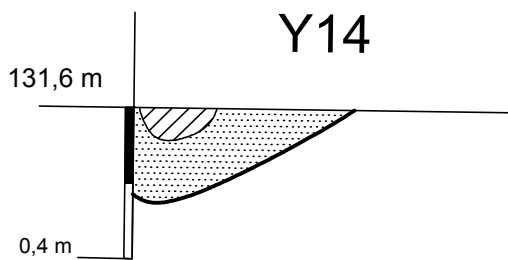

Obj. Nr. 49/13

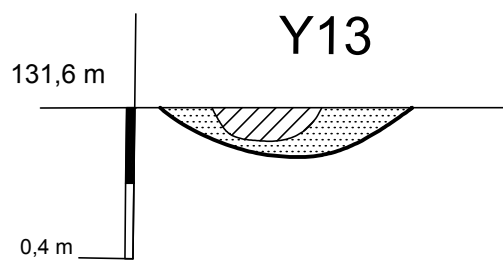

Obj. Nr. 50/14

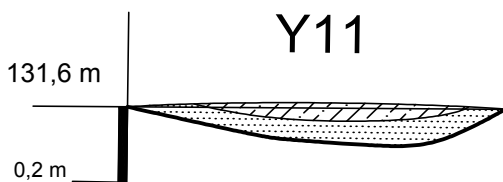

Obj. Nr. 44/8–50/14

M1:20

Brėžinys Nr. 33

P-11 V sienos pjūvis

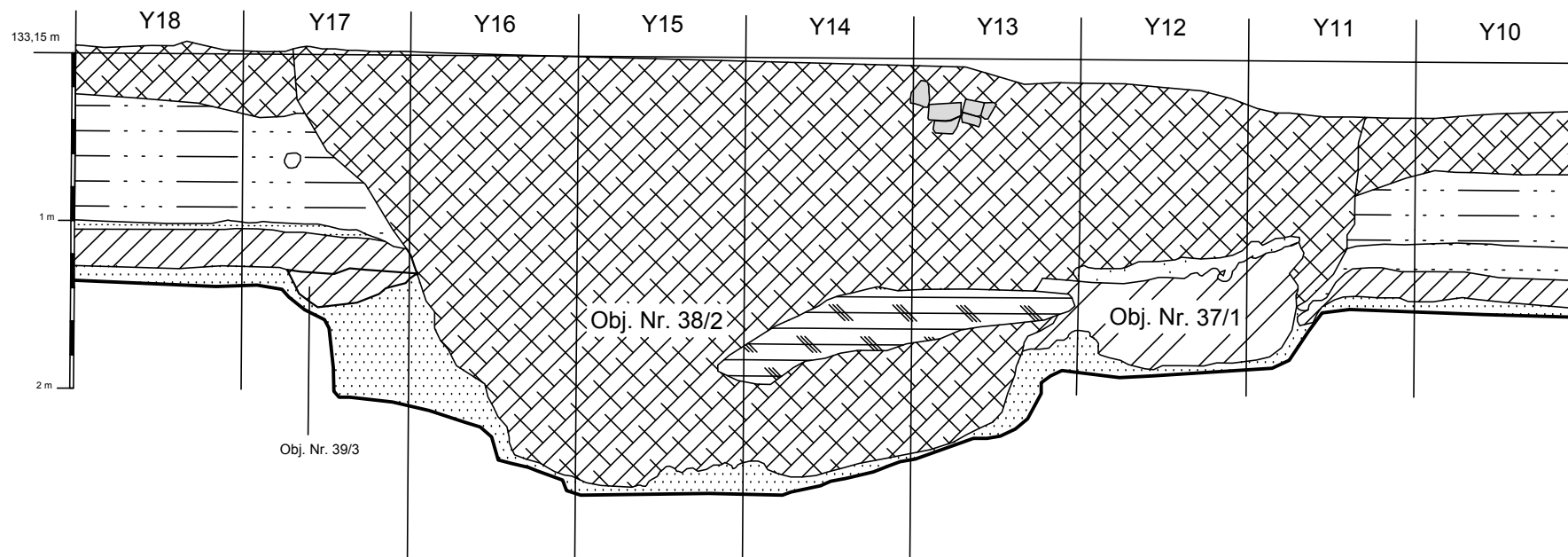

P-11 P sienelės pjūvis

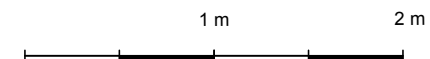
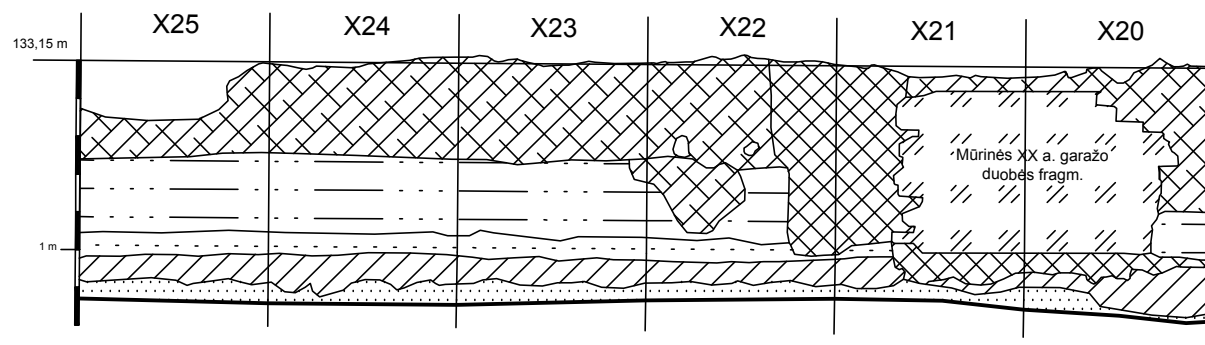

P-11 P, V sienų pjūviai

M1:40

Brėžinys Nr. 34

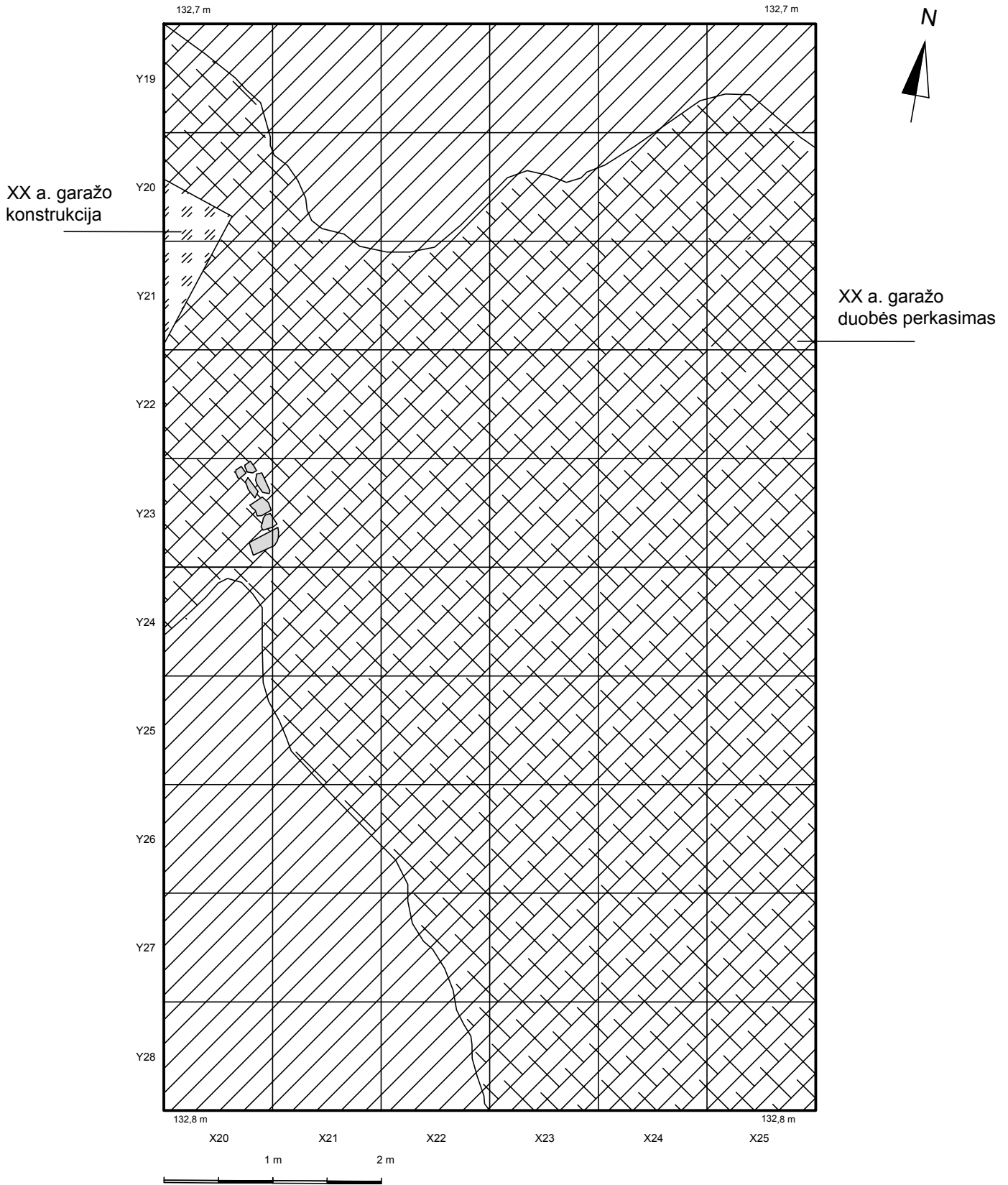

P-12 t. p. ž. sluoksniu (XV a.) sit. planas (0,6 m gylis)

M1:50

Brėžinys Nr. 35

XX a. garažo  
konstrukcija



Pamato duobė

Gyvenamojo namo  
Nr. P1 fragm.

P-12 sit. planas (0,75–0,8 m gylis)

M1:50

Brėžinys Nr. 36

P-12 P sienos pjūvis

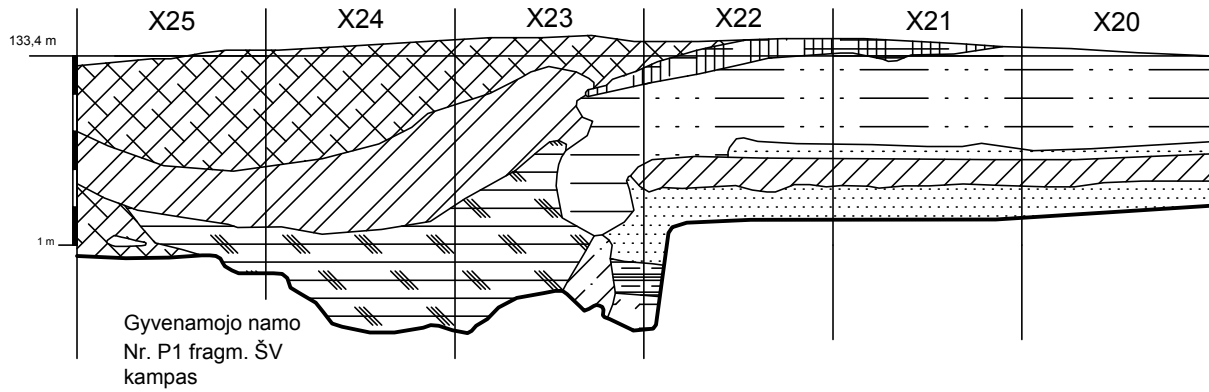

P-12 V sienos pjūvis (Kv. Y28–Y23)

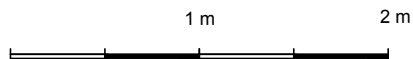
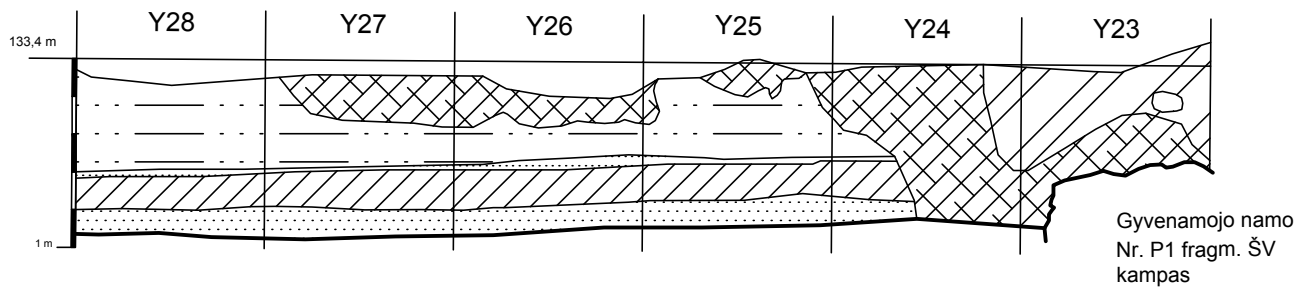

P-12 P sienos pjūvis;  
P-12 V sienos pjūvis (Kv. Y28–Y23)

M1:40

Brėžinys Nr. 37



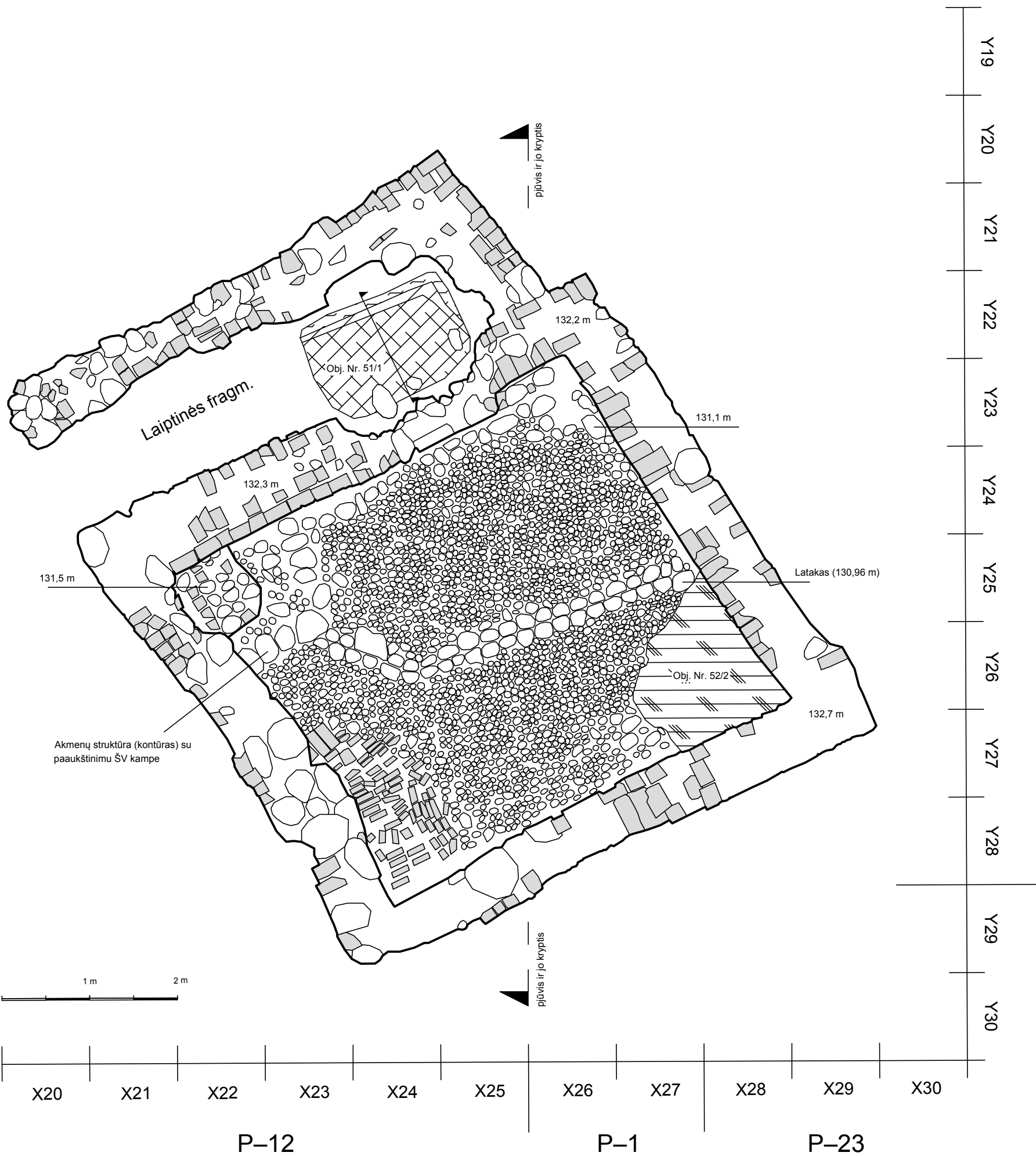

82-P

Gyvenamojo namo Nr. P1 fragm. planas

M1:40

Brėžinys Nr. 38

### Gyvenamojo namo Nr. P1 rūšio P siena

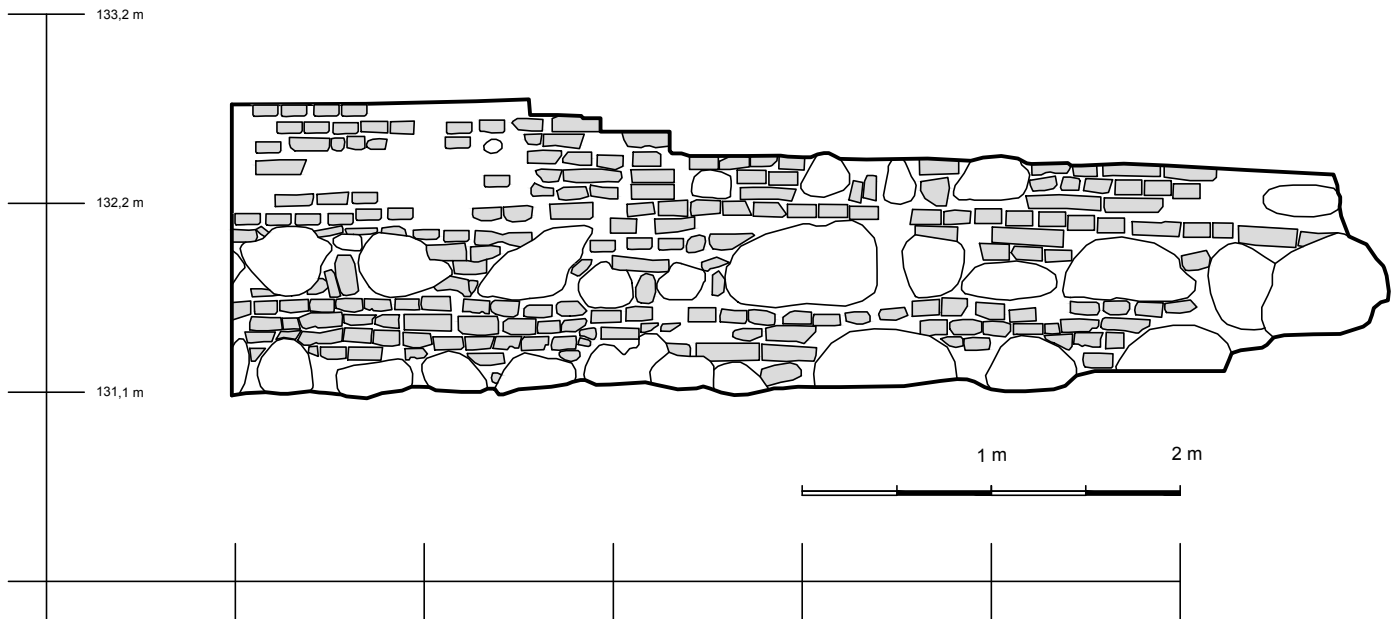

### Gyvenamojo namo Nr. P1 rūšio V siena

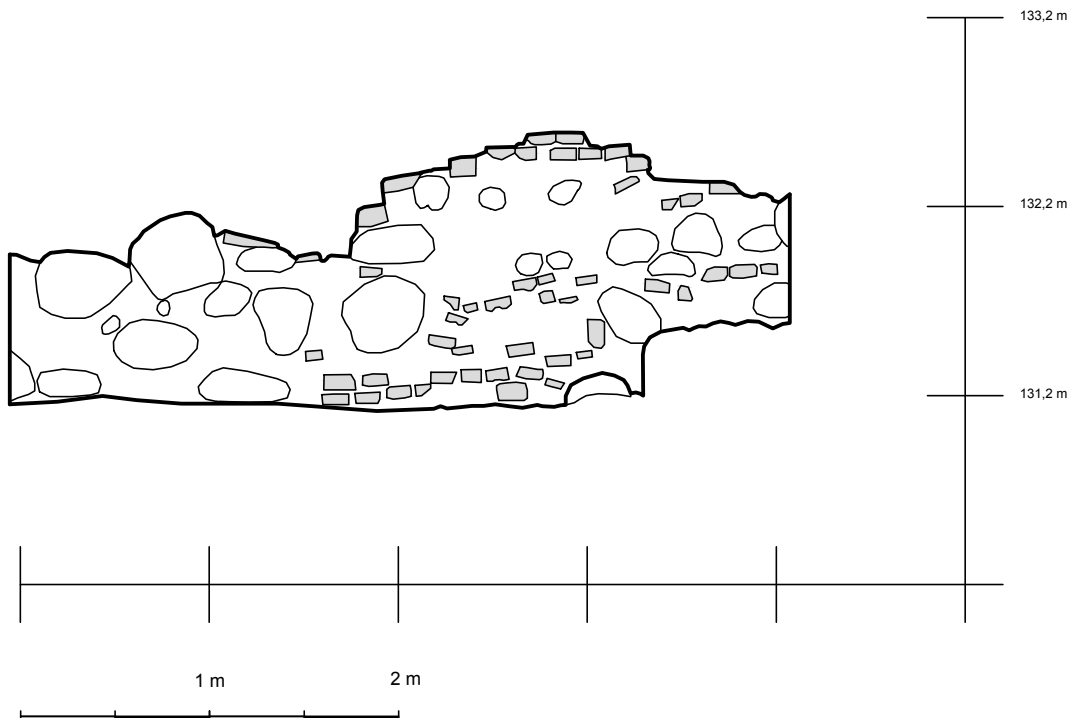

Gyvenamojo namo Nr. P1 rūšio P, V sienos

M1:40

Brėžinys Nr. 39

## Gyvenamojo namo Nr. P1 rūšio Š siena



## Gyvenamojo namo Nr. P1 rūšio R siena

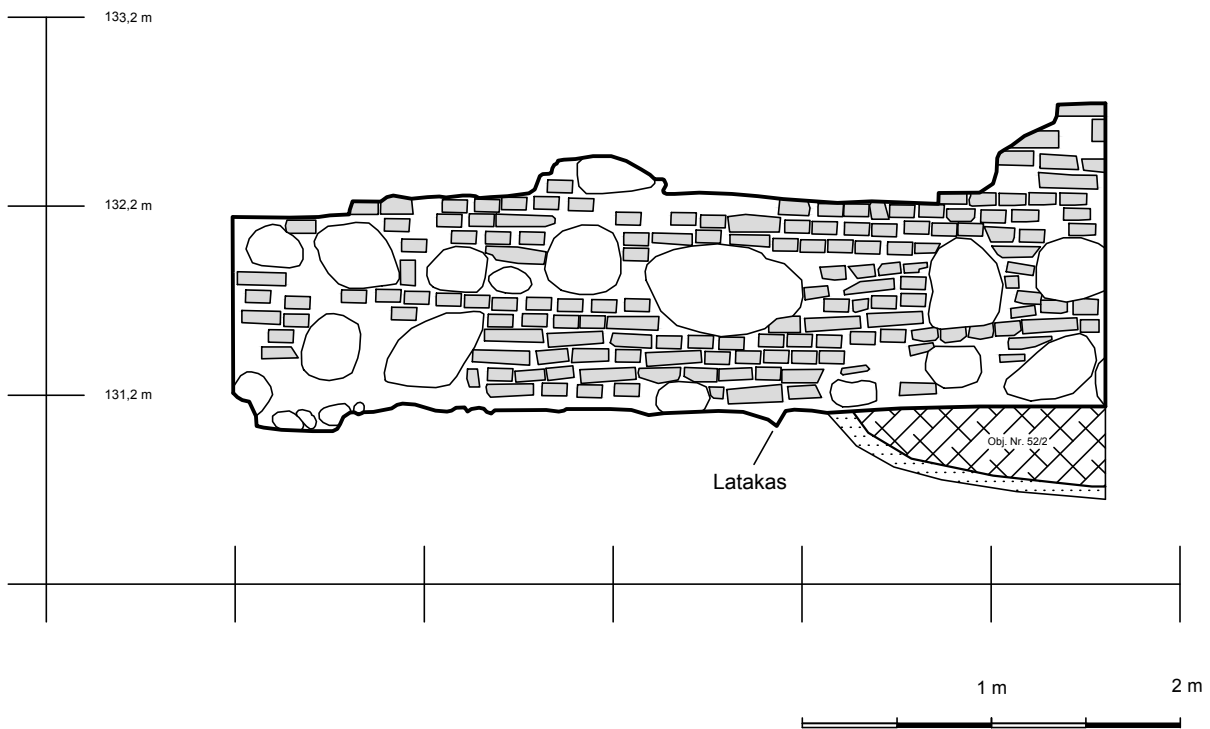

Gyvenamojo namo Nr. P1 rūšio Š, R sienos

M1:40

Brėžinys Nr. 40

### Gyvenamojo namo Nr. P1 laiptinės į rūšį Š siena

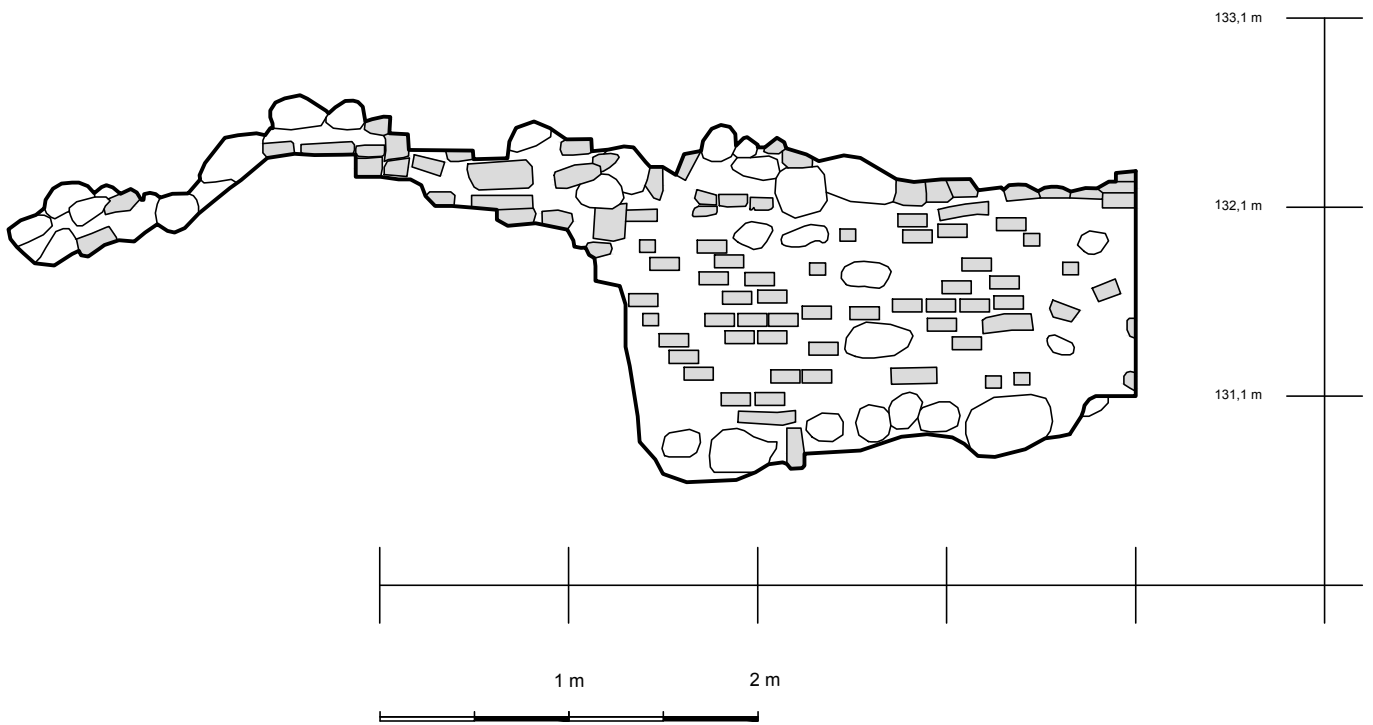

### Gyvenamojo namo Nr. P1 laiptinės į rūšį R siena

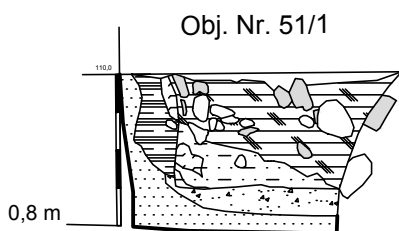
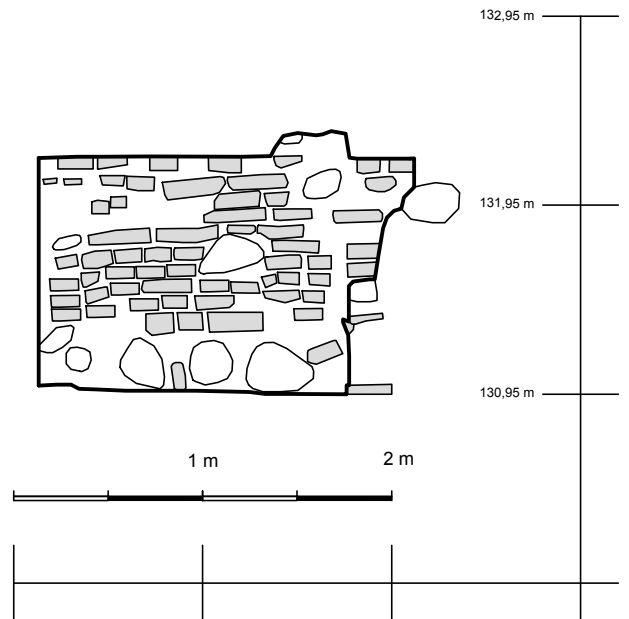

Gyvenamojo namo Nr. P1 Š, R sienos ir obj. Nr. 51/1

M1:40

Brėžinys Nr. 41

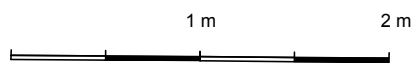
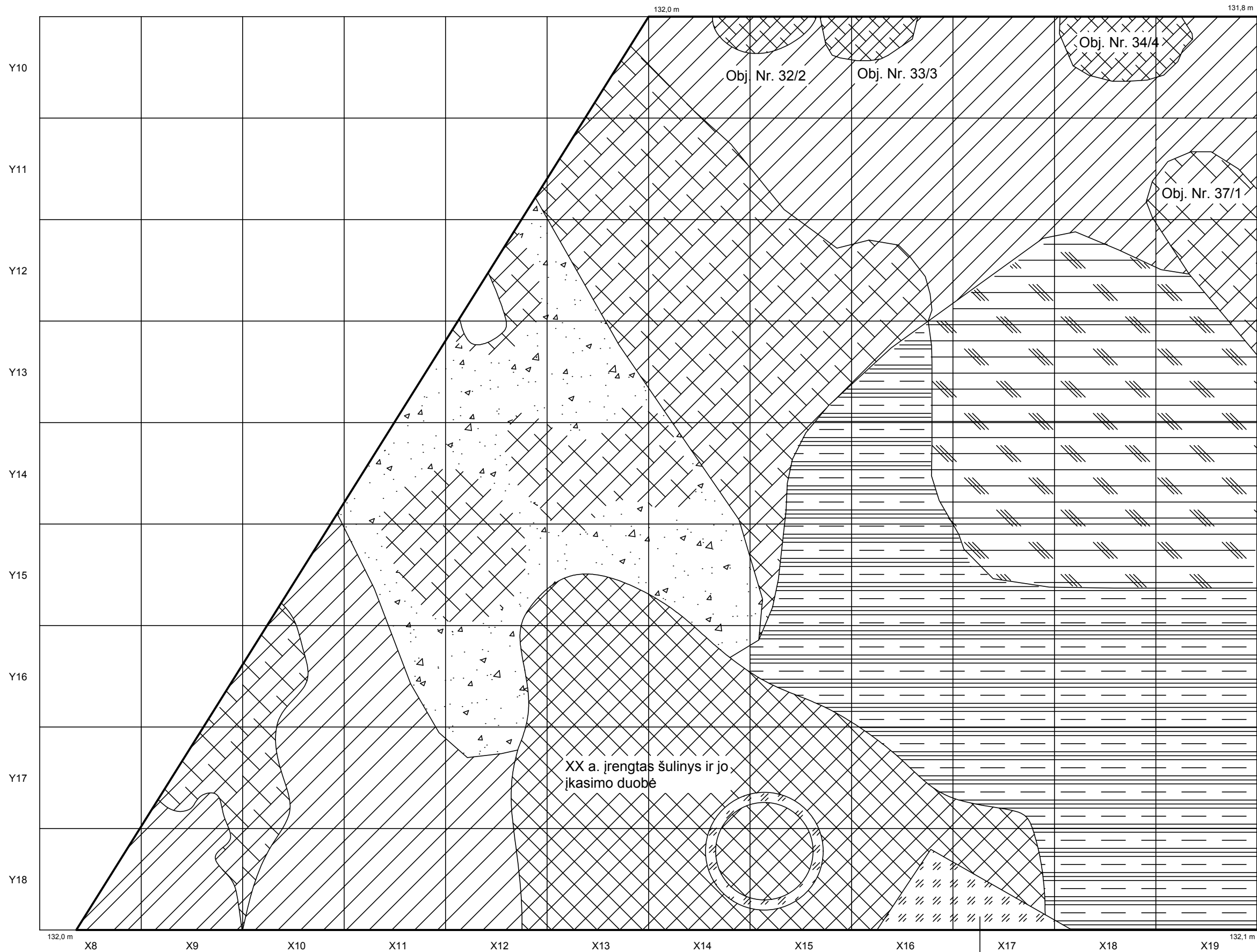

XX a. garažo  
konstrukcija

P-13 t. p. ž. sluoksnio (XV a.) sit. planas  
(0,8–0,9 m gylis)

M1:40

Brėžinys Nr. 42

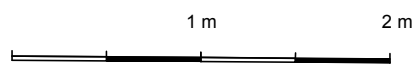
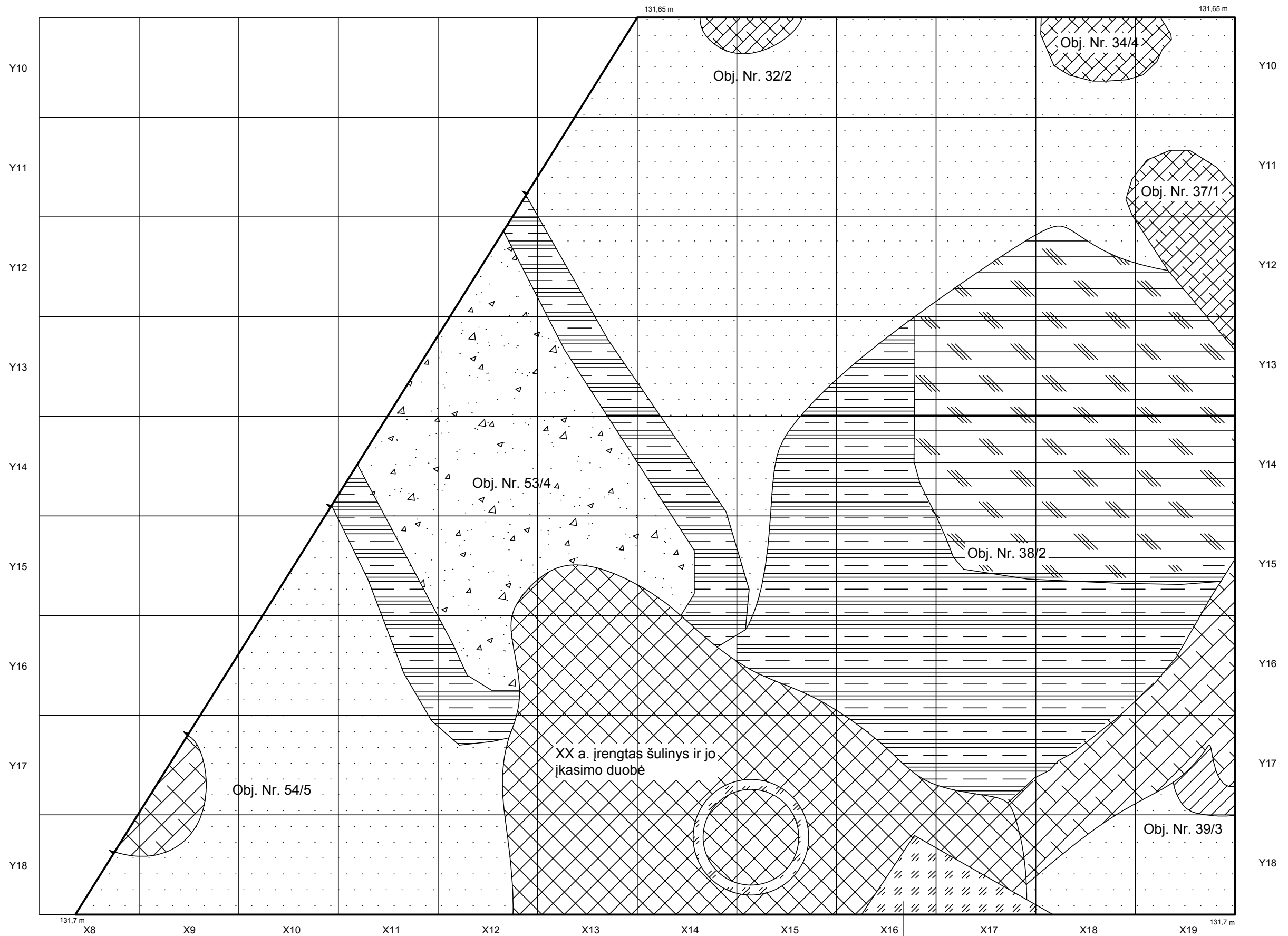

P-13 obj. sit. planas įžemyje (1-1,1 m gylis)
M1:40
Brėžinys Nr. 43

P-13 ŠV sienos pjūvis

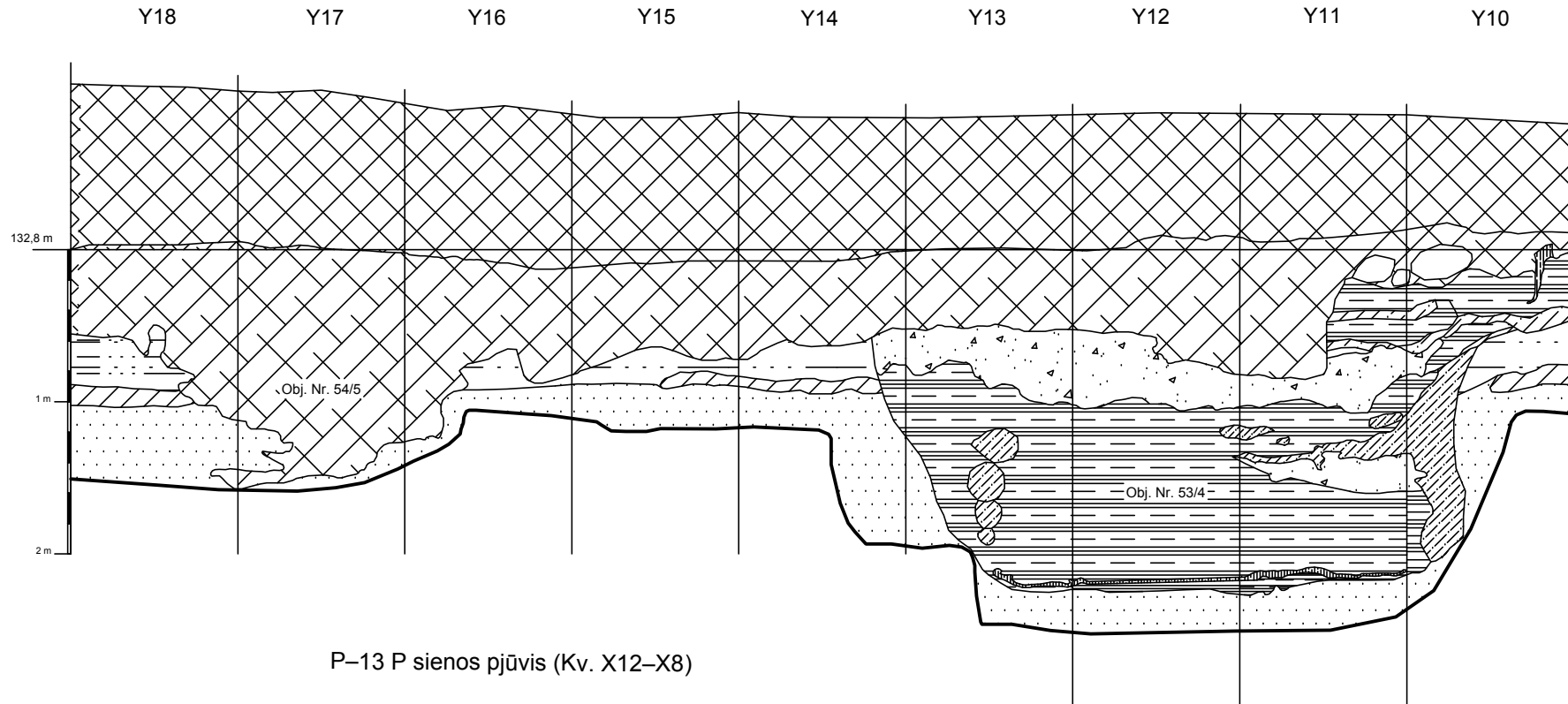

P-13 P sienos pjūvis (Kv. X12-X8)

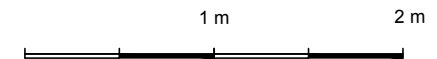
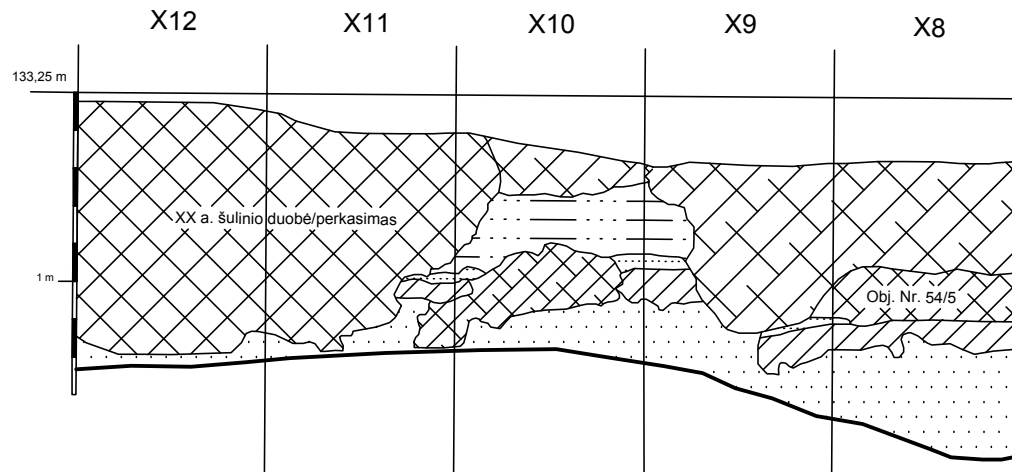

P-13 P, ŠV sienų pjūviai

M1:40

Brėžinys Nr. 44

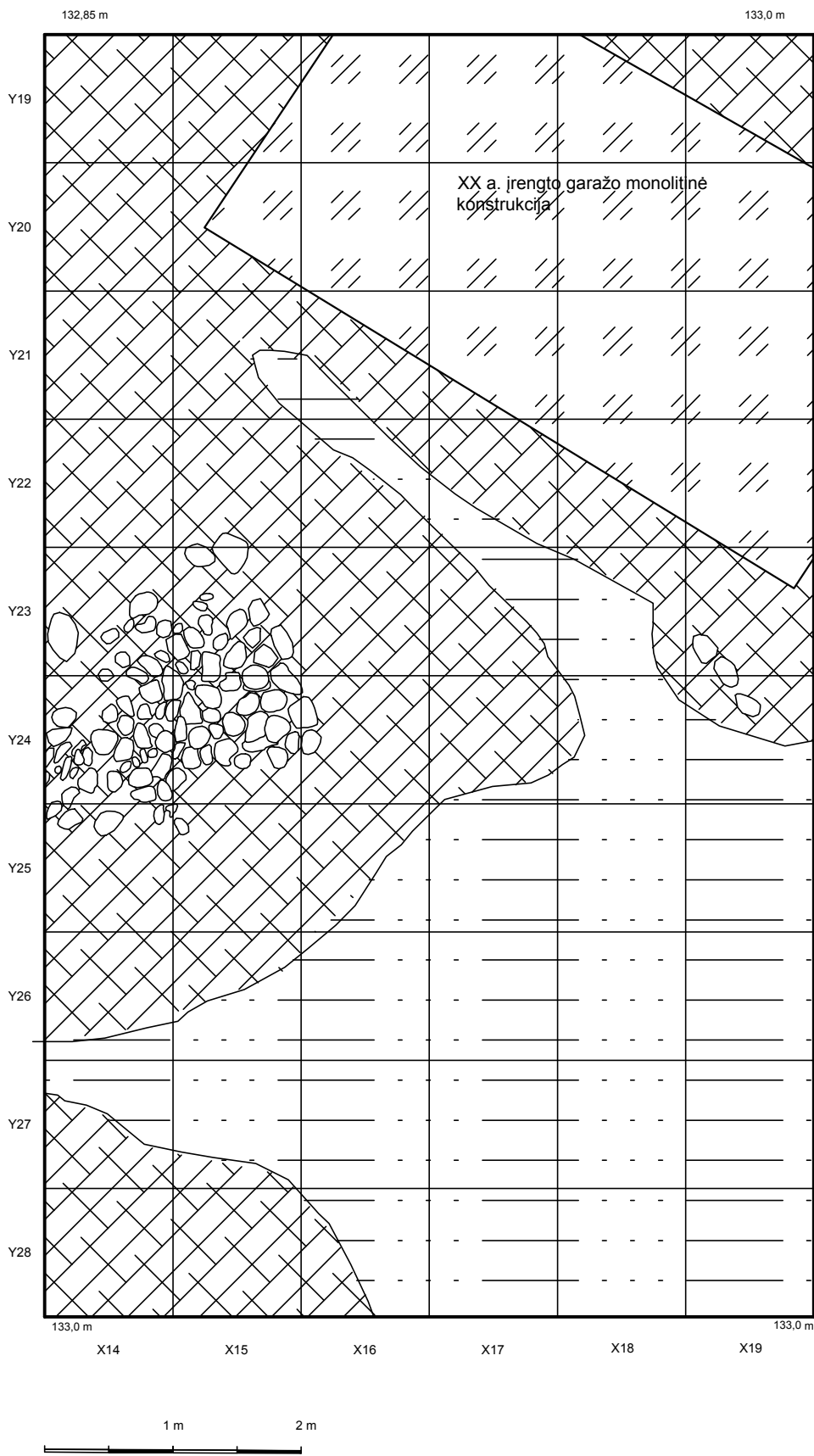

P-14 sit. planas (0,2 m gylis)

M1:50

Brėžinys Nr. 45



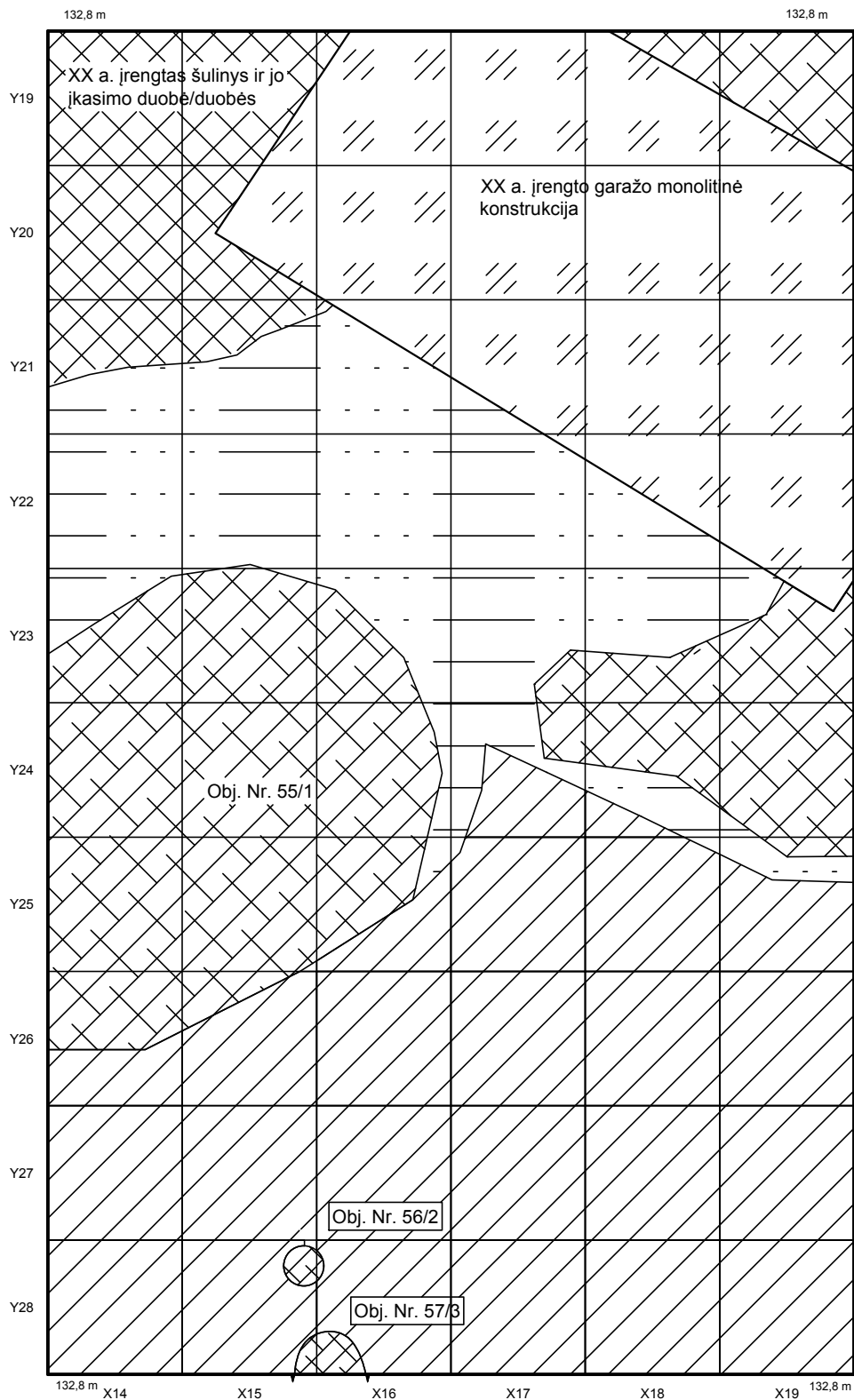

P-14 t. p. ž. sluoksniu (XV a.) sit. planas (0,5–0,6 m gylis)

M1:50

Brėžinys Nr. 46

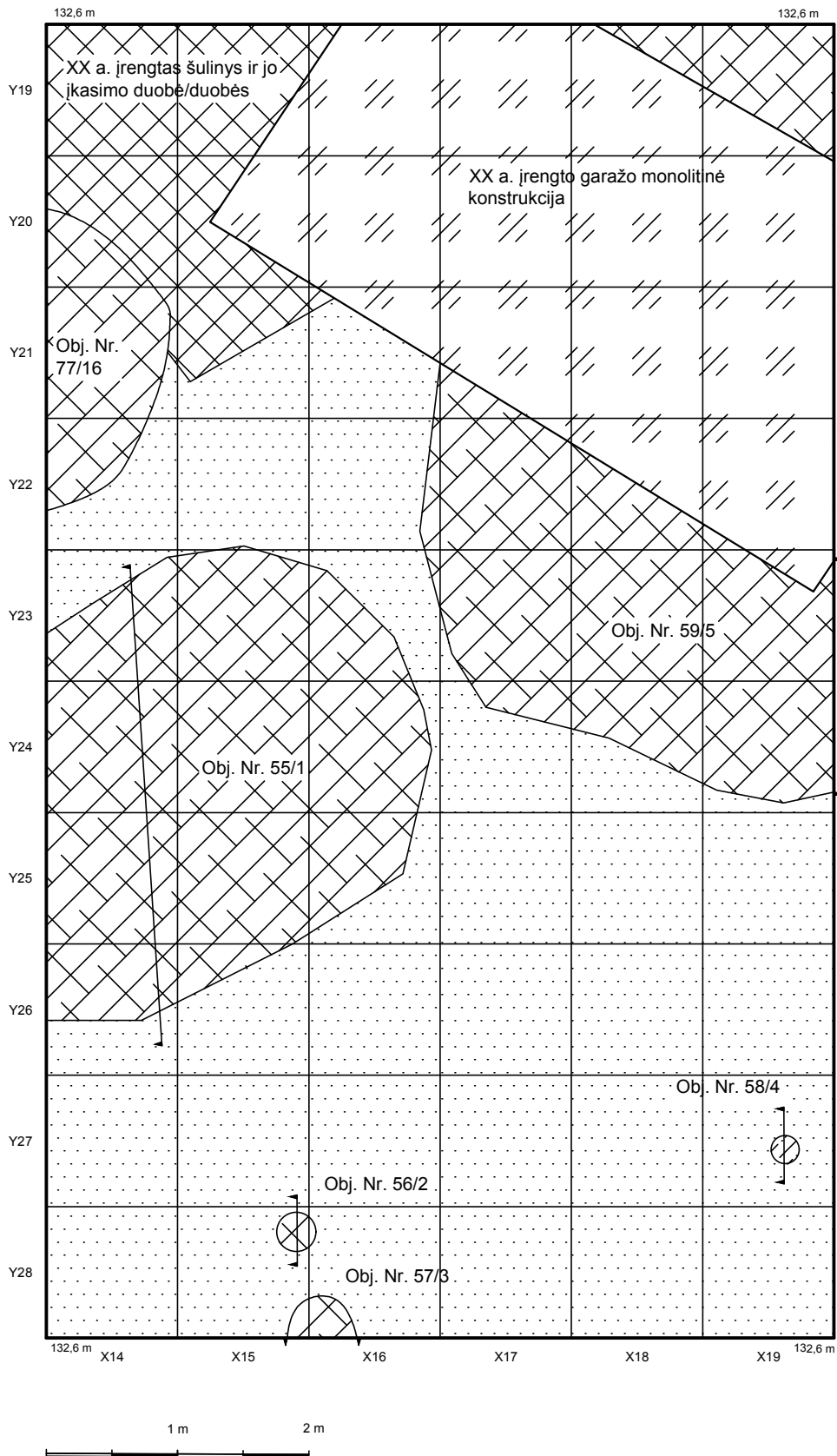

P-14 obj. sit. planas įžemyje (0,6–0,7 m gylis)

M1:50

Brėžinys Nr. 47

P-14 P sienos pjūvis

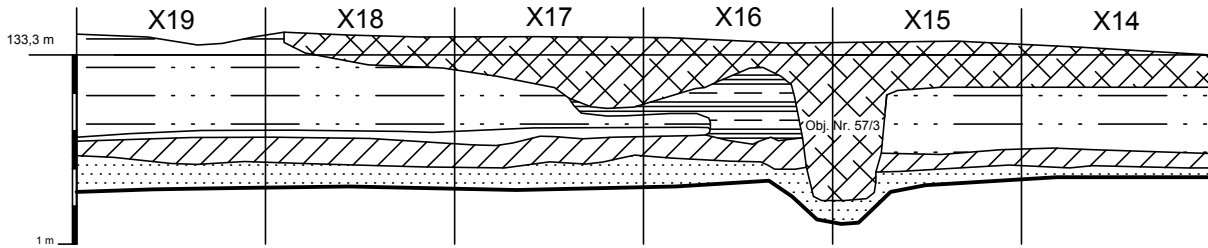

P-14 V sienos pjūvis (Kv. Y28-Y23)

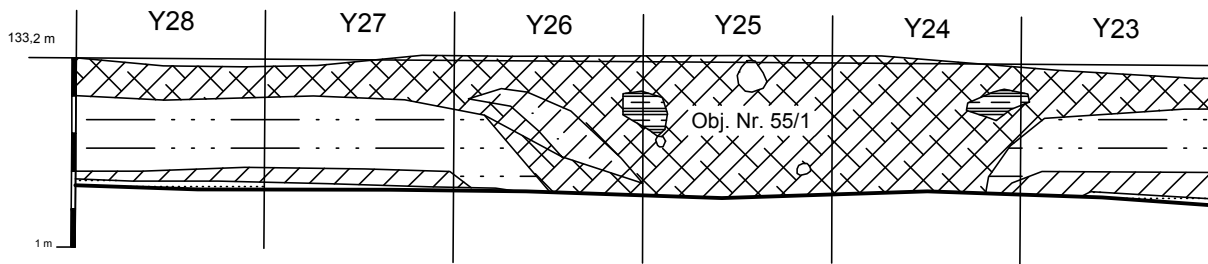

Obj. Nr. 55/1

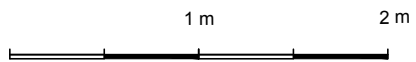
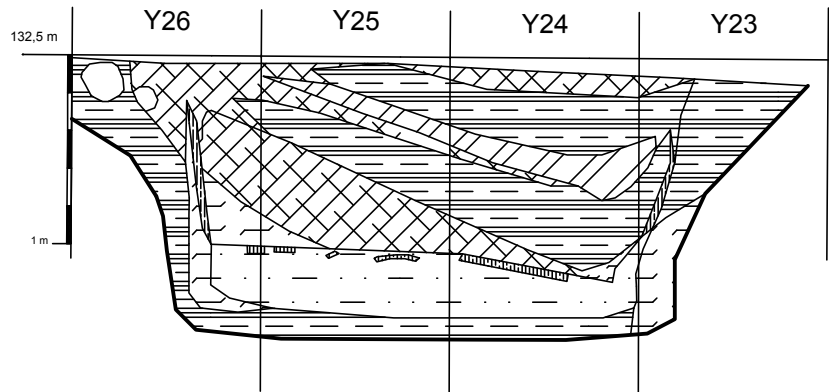

P-14 P sienos pjūvis;  
P-14 V sienos pjūvis (Kv. Y28-Y23);  
Obj. Nr. 55/1 pjūvis

M1:40

Brēžinys Nr. 48

# Obj. Nr. 60/6

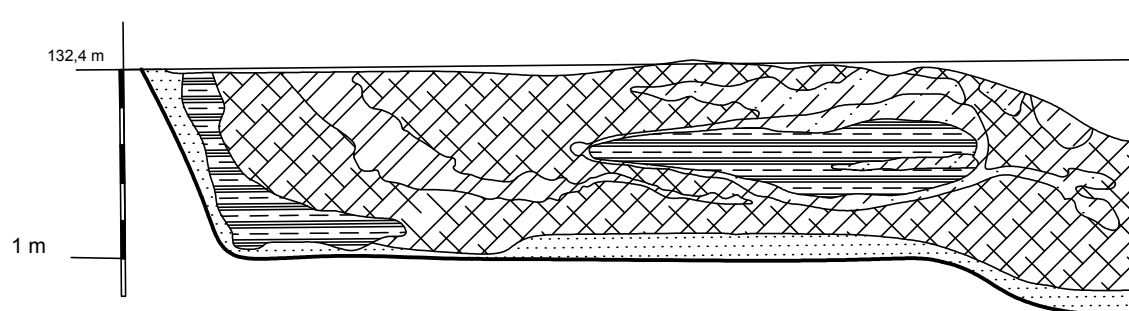

## Obj. Nr. 61/7

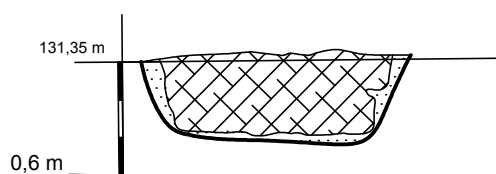

## Obj. Nr. 62/8

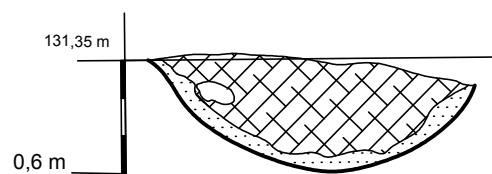

Obj. Nr. 60/6–62/8

M1:40

Brėžinys Nr. 49

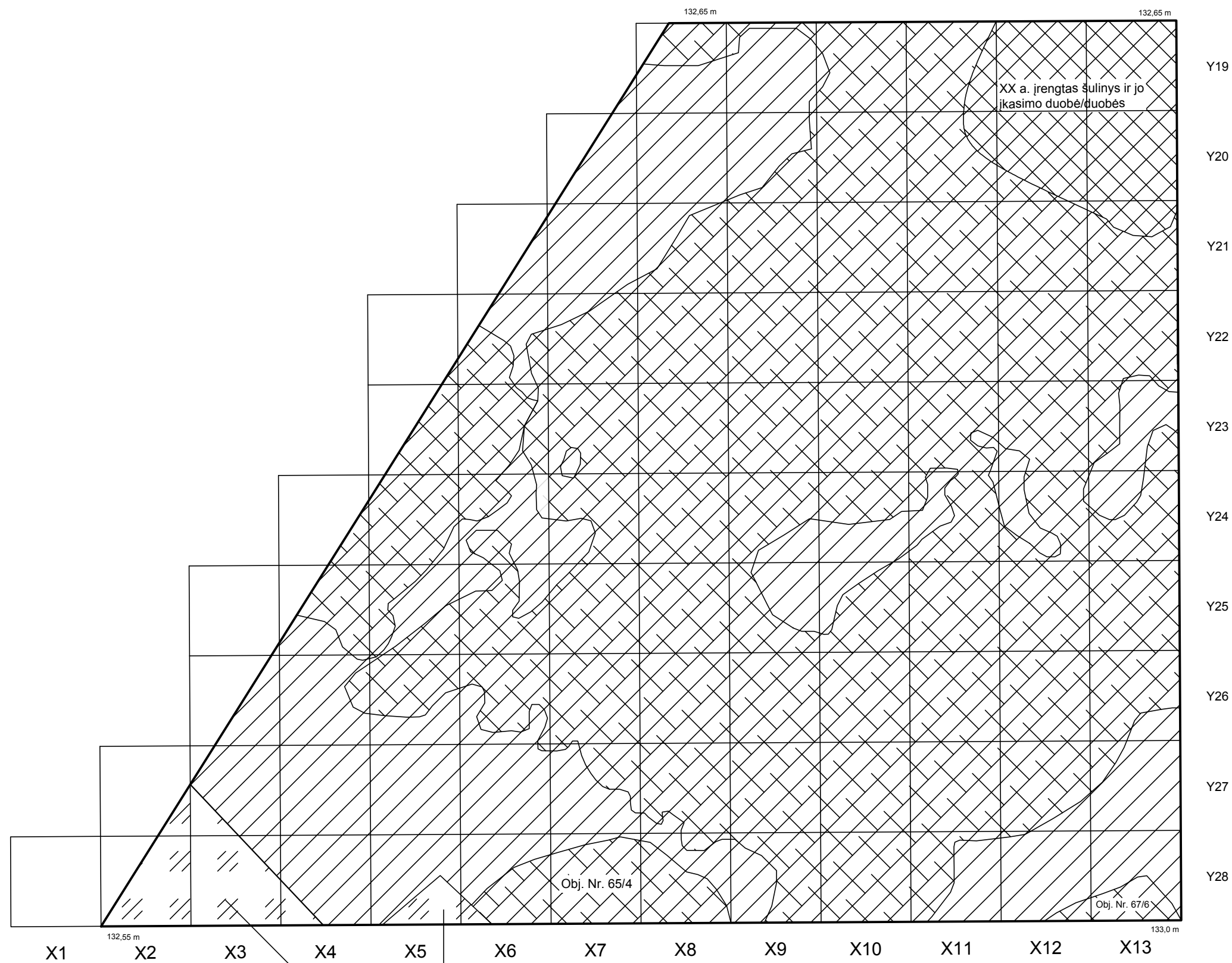

XX a. įrengtas šulinys ir jo  
ikasimo duobė/duobės

Obj. Nr. 65/4

Obj. Nr. 67/6

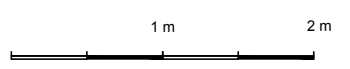

XX a. įrengtų garažų  
konstrukcijų fragm.

P-15 t. p. ž. sluksnio (XV a.) sit. planas (0,3–0,6 m gylis)	
M1:50	
Brėžinys Nr. 50	60

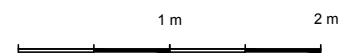
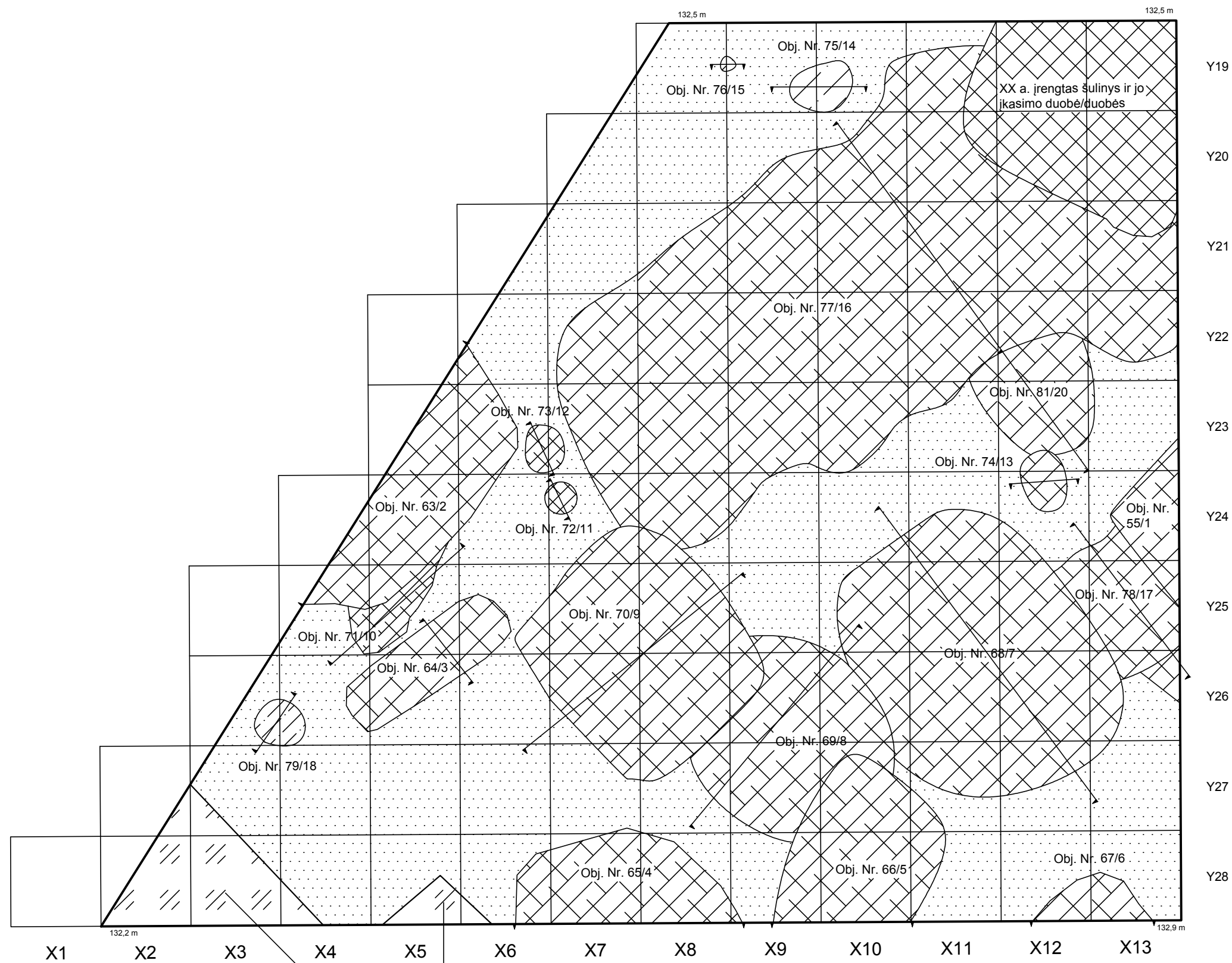

XX a. įrengtų garažų konstrukcijų fragm.

P-15 obj. sit. planas įžemyje (0,45–0,75 m gylis)
M1:50
Brėžinys Nr. 51

Obj. Nr. 68/7

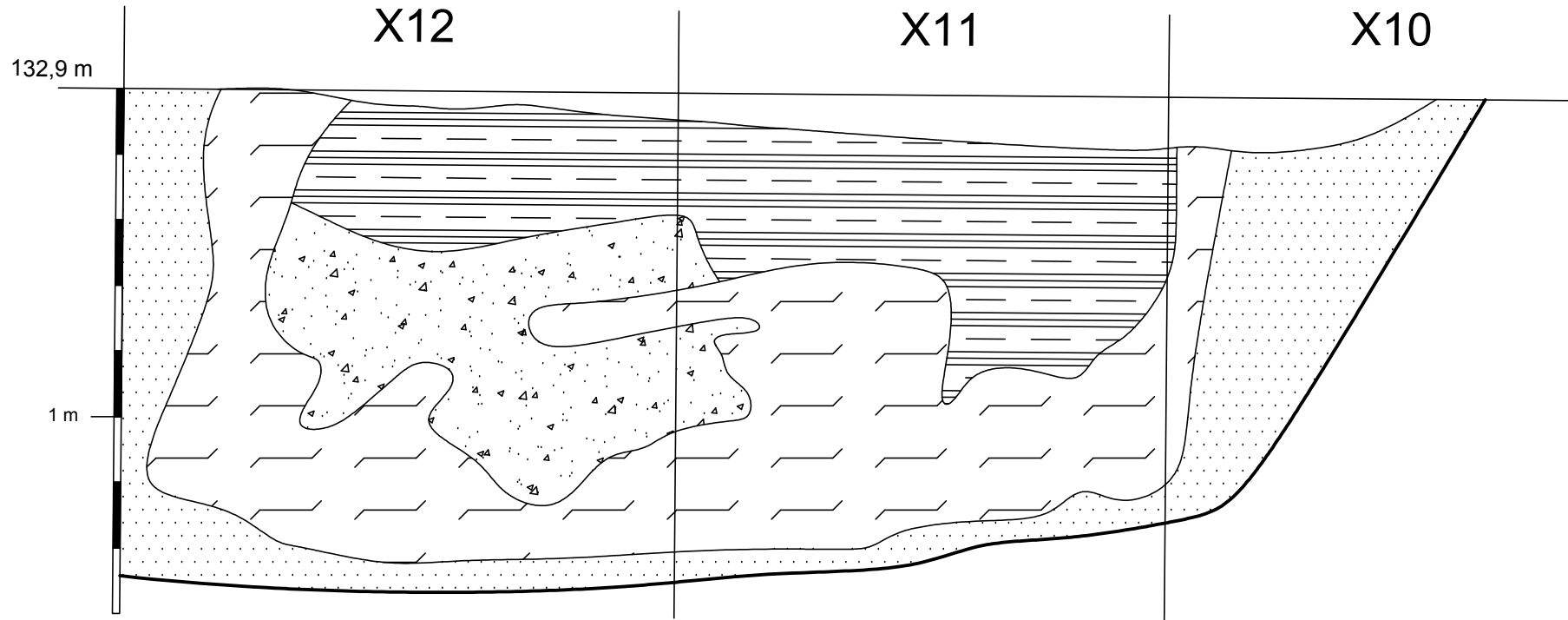

Obj. Nr. 64/3, Obj. Nr. 80/19

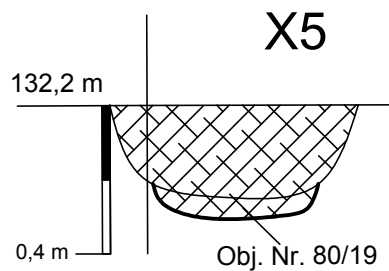

Obj. Nr. 64/3, 68/7, 80/19

M1:20

Brėžinys Nr. 52

Obj. Nr. 69/8

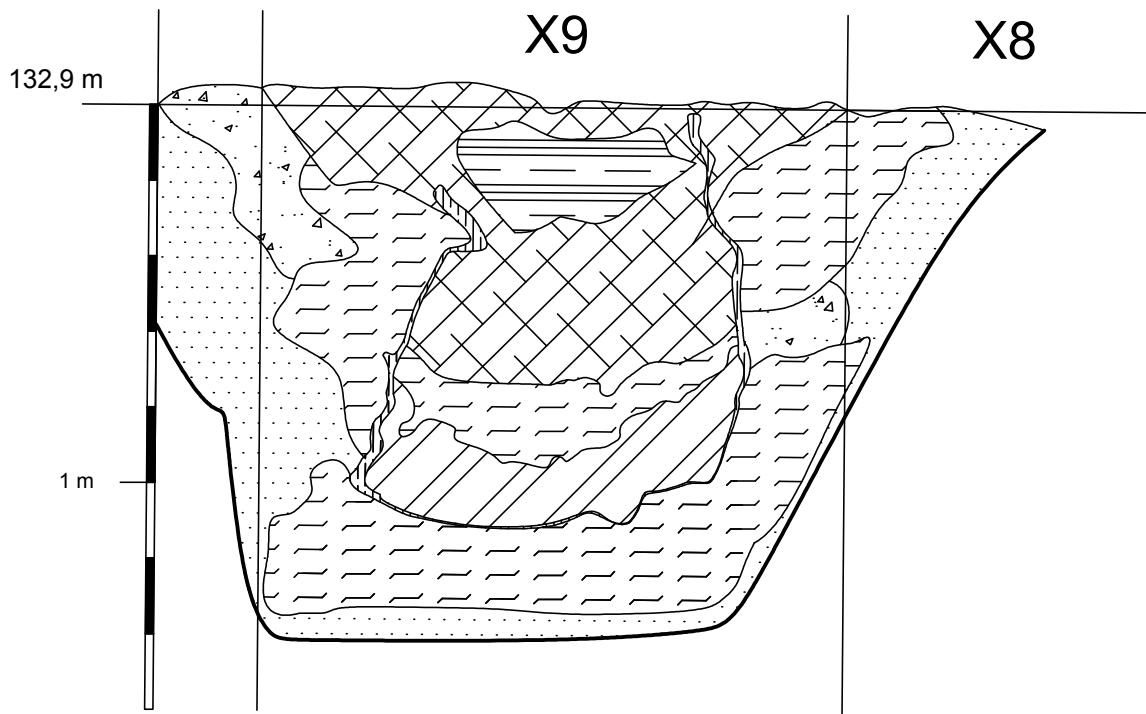

Obj. Nr. 70/9

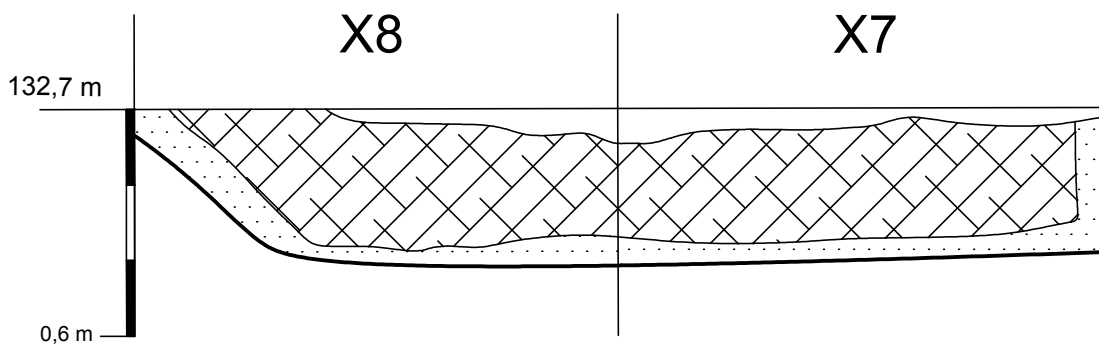

Obj. Nr. 71/10

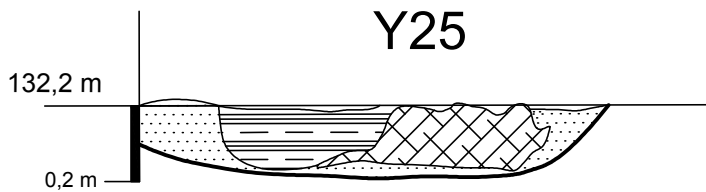

Obj. Nr. 72/11

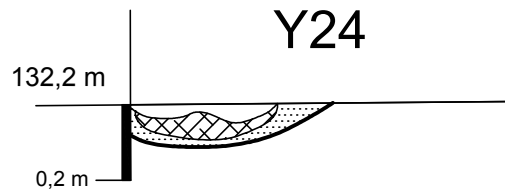

Obj. Nr. 69/8–72/11

M1:20

Brėžinys Nr. 53



Obj. Nr. 73/12

Obj. Nr. 74/13

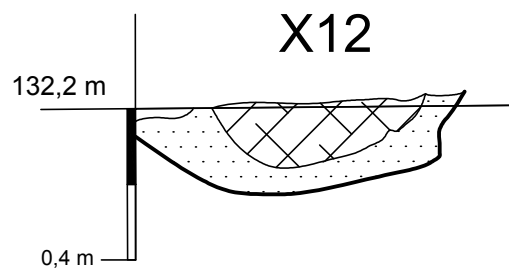
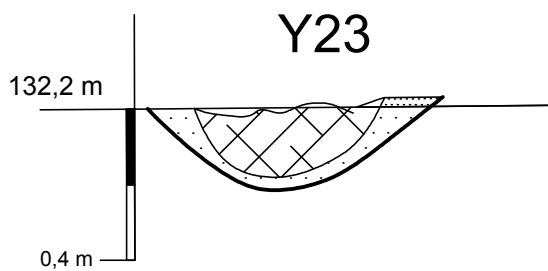

Obj. Nr. 75/14

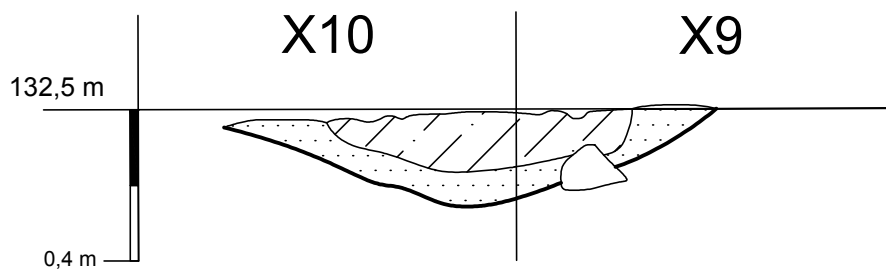

Obj. Nr. 78/17

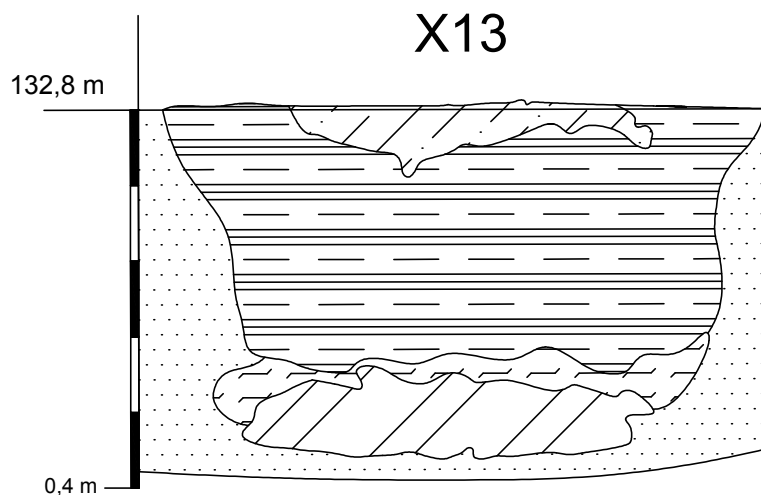

Obj. Nr. 73/12–75/14, 78/17

M1:20

Brėžinys Nr. 54

Obj. Nr. 81/20

Obj. Nr. 77/16

X12

X11

X10

132,5 m

1 m

0,2 m

1 m

Obj. Nr. 77/16, 81/20

M1:20

Brėžinys Nr. 55

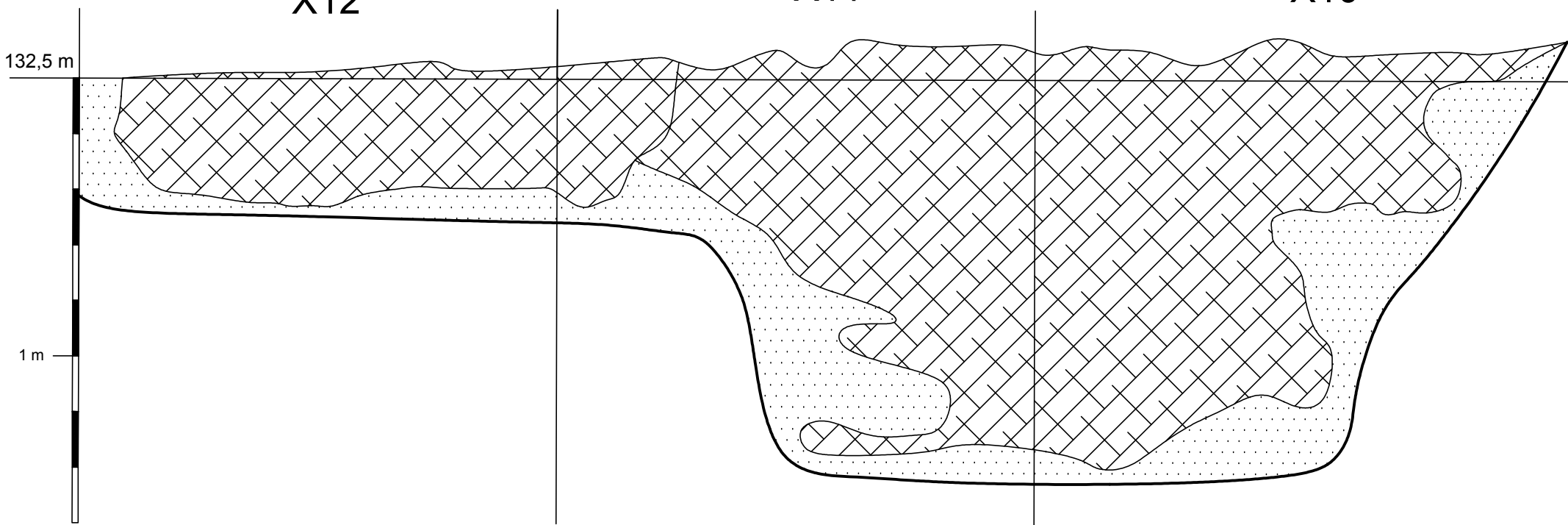

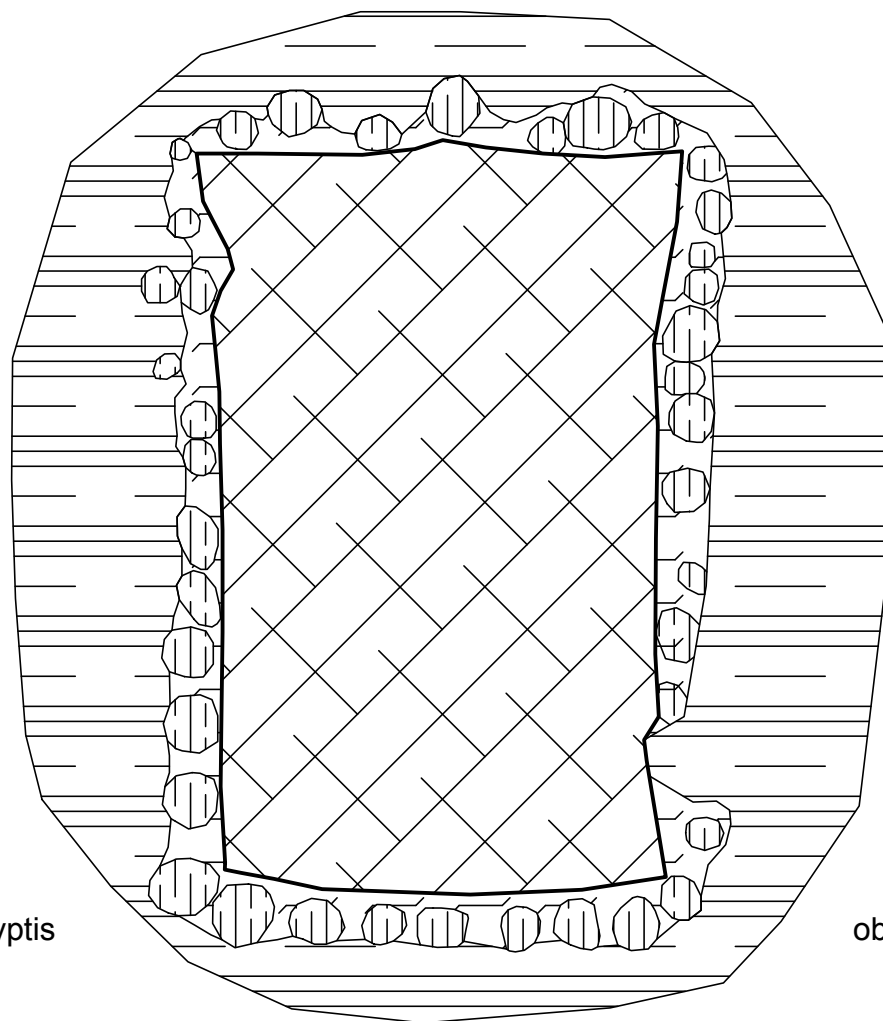

129,75 m

129,75 m



objekto pjūvio kryptis



objekto pjūvio kryptis



Obj. Nr. 82/21 planas

M1:20

Brėžinys Nr. 56

Obj. Nr. 82/21 konstrukcijos pjūvis

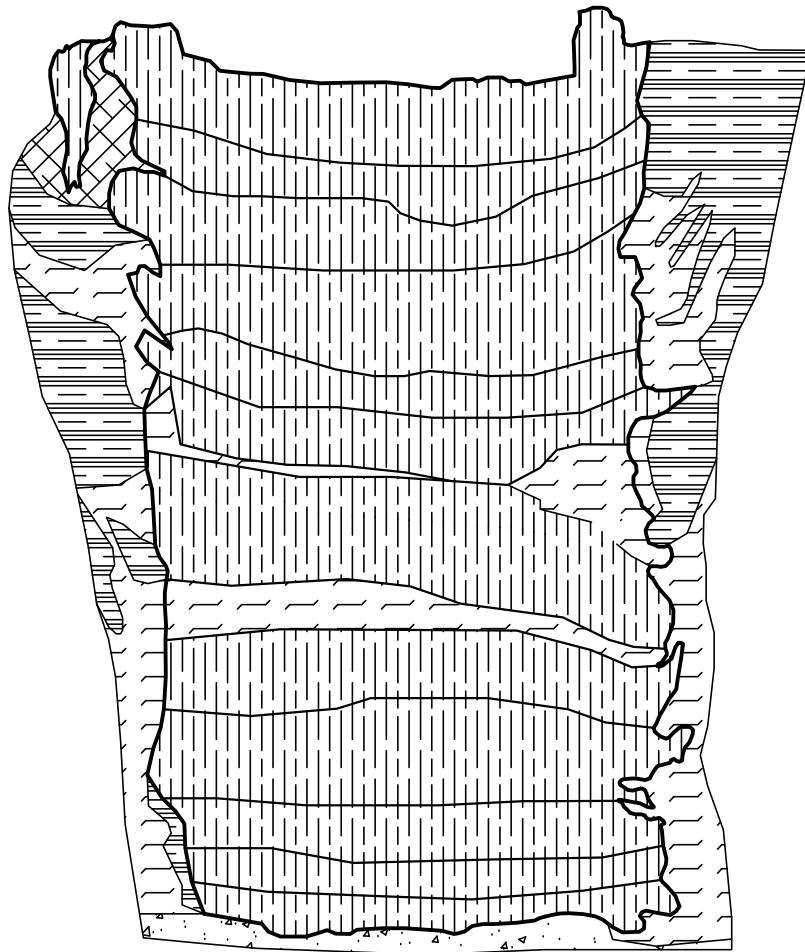

Obj. Nr. 82/21 užpildo pjūvis

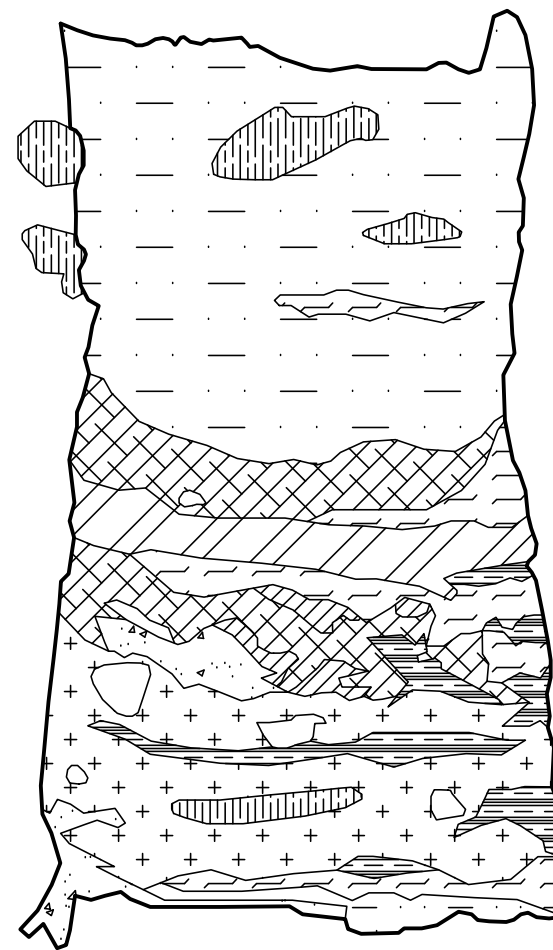

Obj. Nr. 82/21 konstrukcijos ir užpildo pjūvis

M1:20

Brėžinys Nr. 57



P-16 sit. planas (0,1–0,2 m gylis)

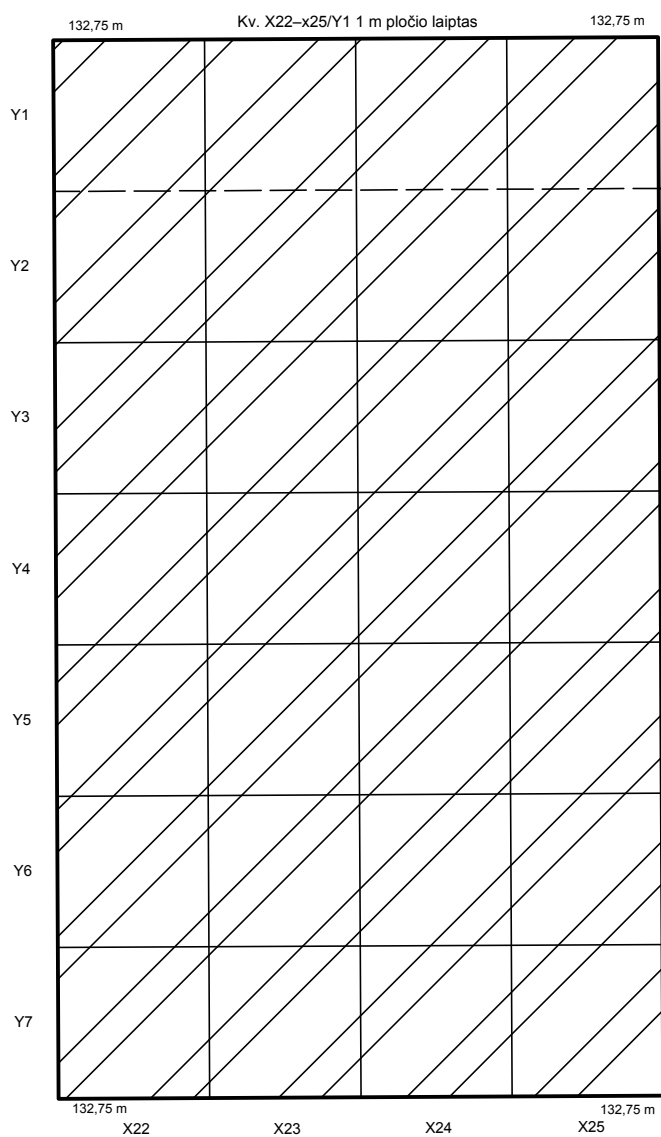

1 m 2 m

P-16 sit. planas (0,4–0,5 m gylis)

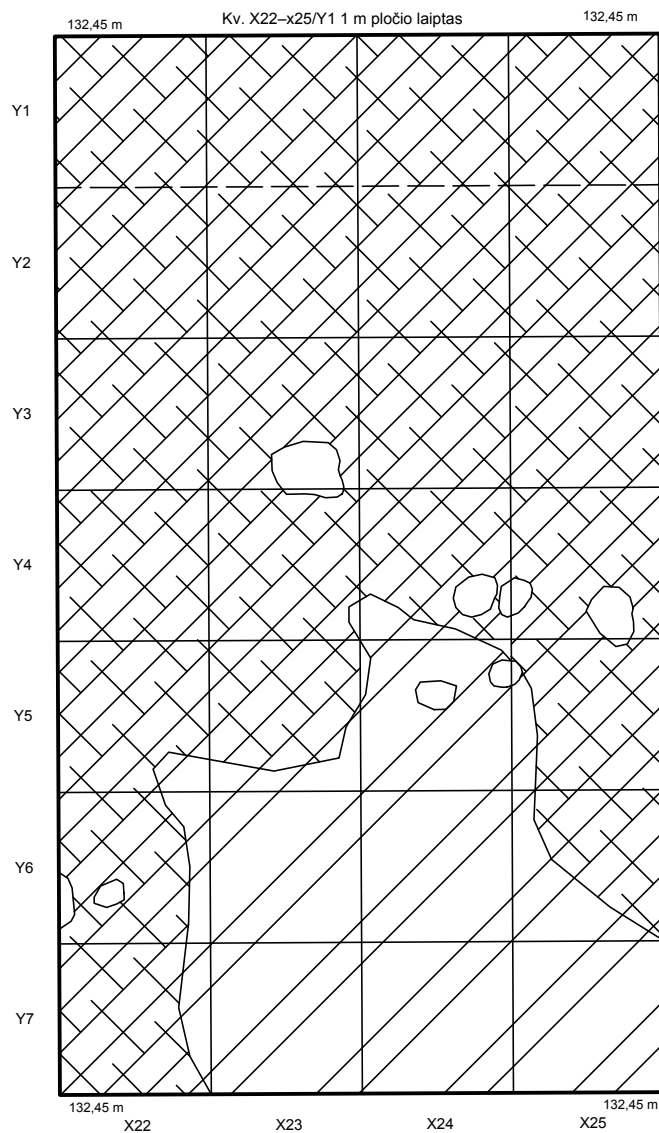

1 m 2 m

P-16 sit. planas (0,1–0,2 m gylis); P-16 sit. planas (0,4–0,5 m gylis)

M1:50

Brėžinys Nr. 58



P-16 t. p. ž. sluoksnio (XV a.) sit. planas  
(1,5–1,6 m gylis)

P-16 obj. sit. planas įžemyje (1,6–1,7 m gylis)

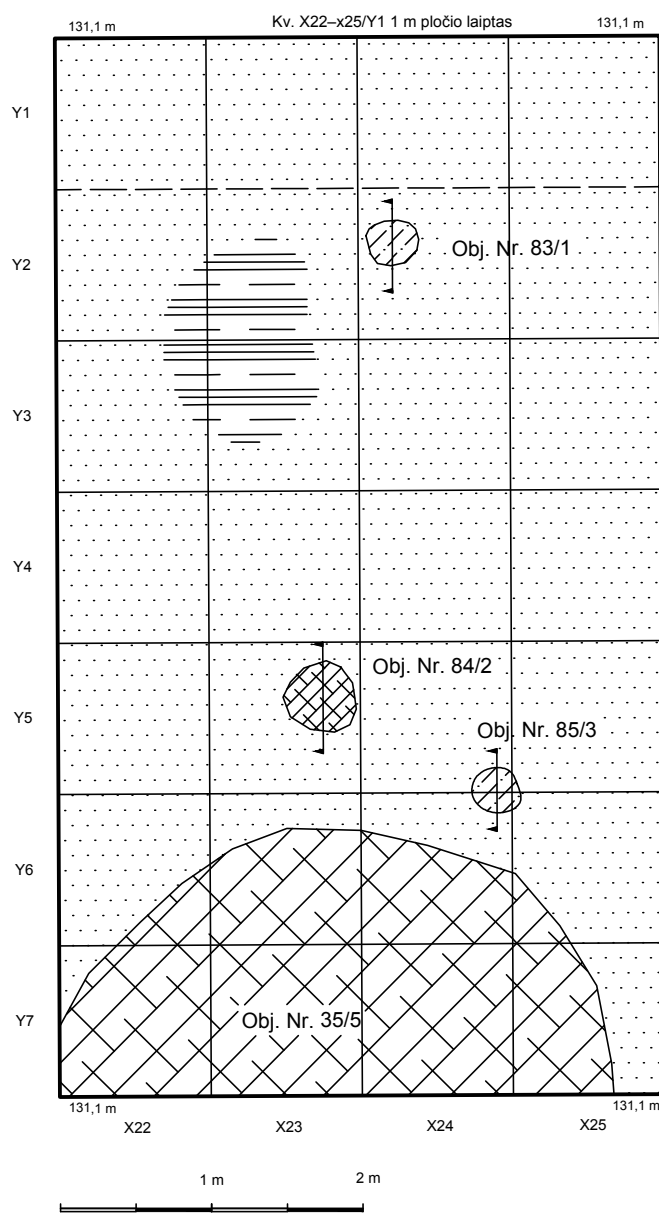
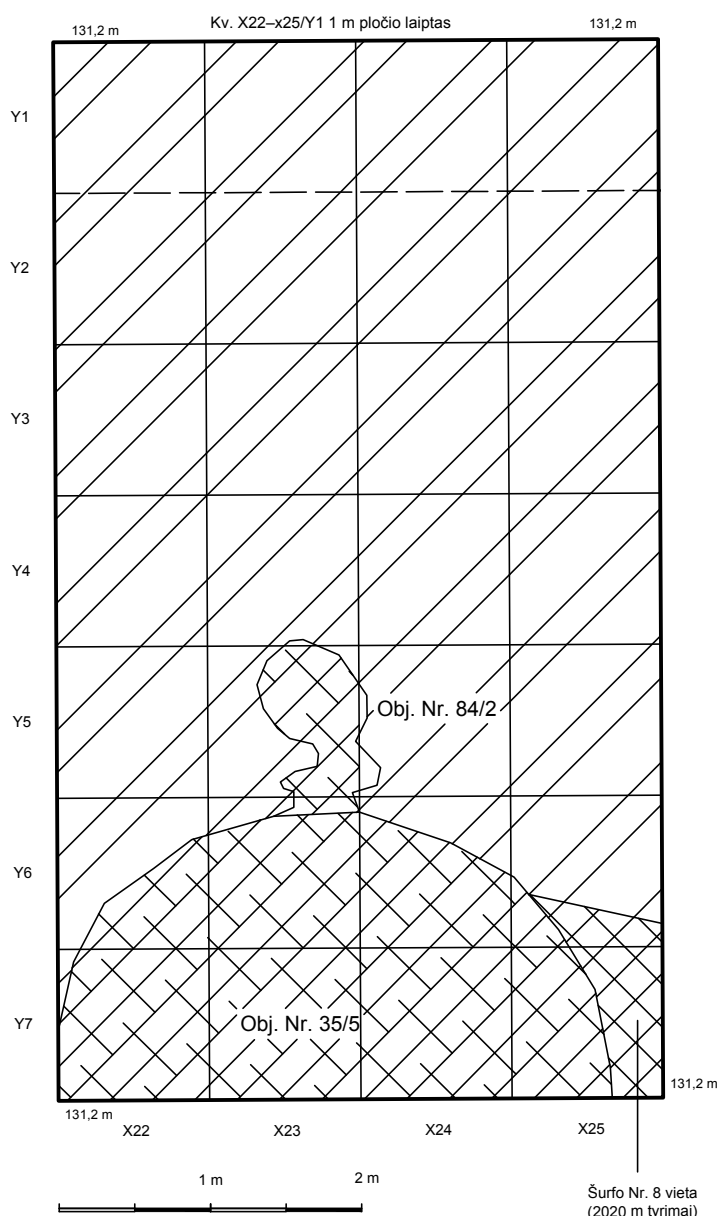

P-16 t. p. ž. sluoksnio (XV a.) sit. planas (1,5–1,6 m gylis);  
P-16 obj. sit. planas įžemyje (1,6–1,7 m gylis)

M1:50

Brėžinys Nr. 59

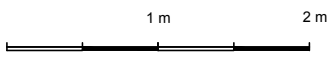
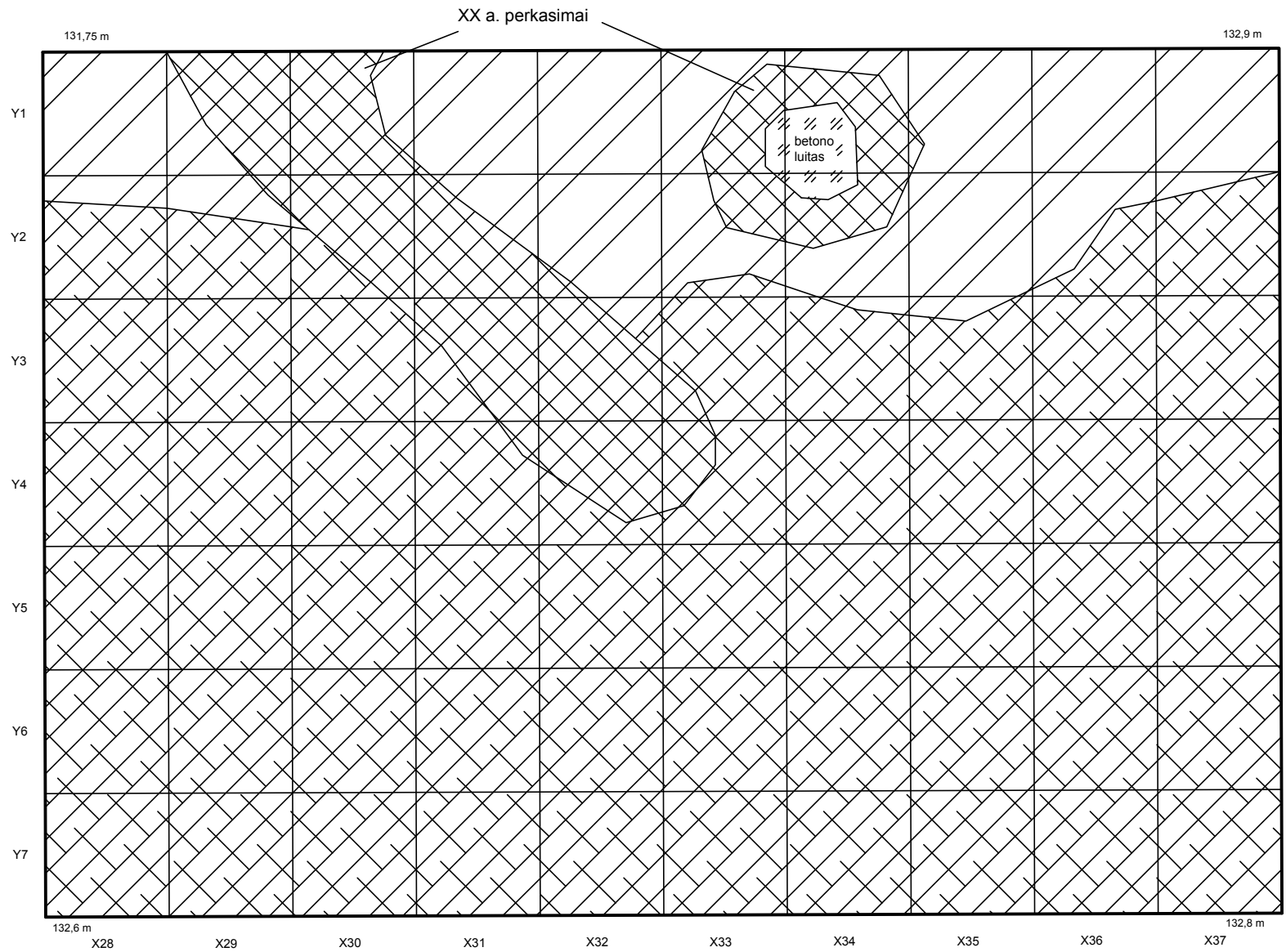

P-17 sit. planas (0,2 m gylis)

M1:50

Brėžinys Nr. 60

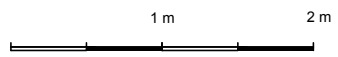
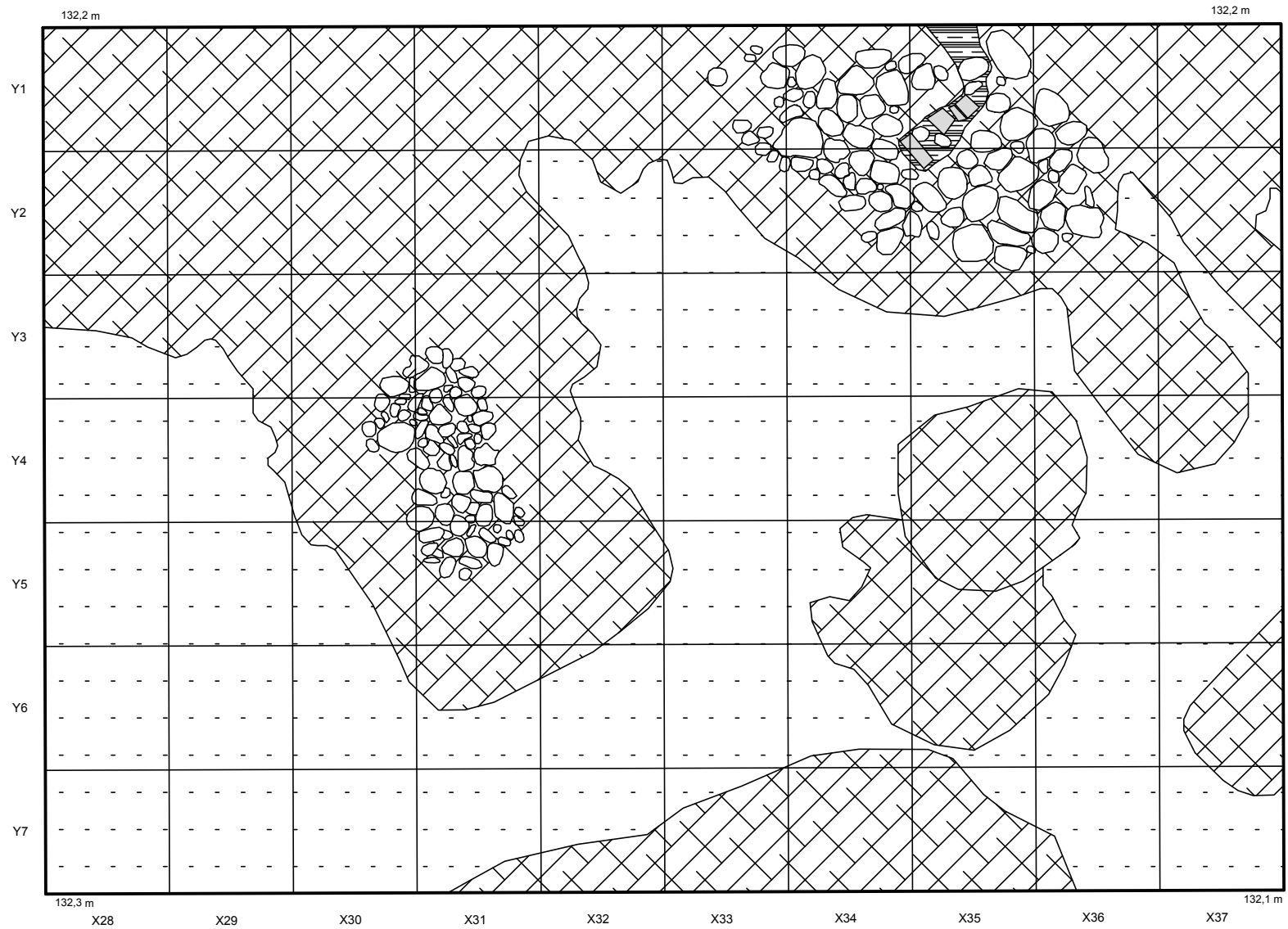

P-17 sit. planas (0,7–0,9 m gylis)	
M1:50	
Brėžinys Nr. 61	71



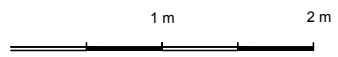
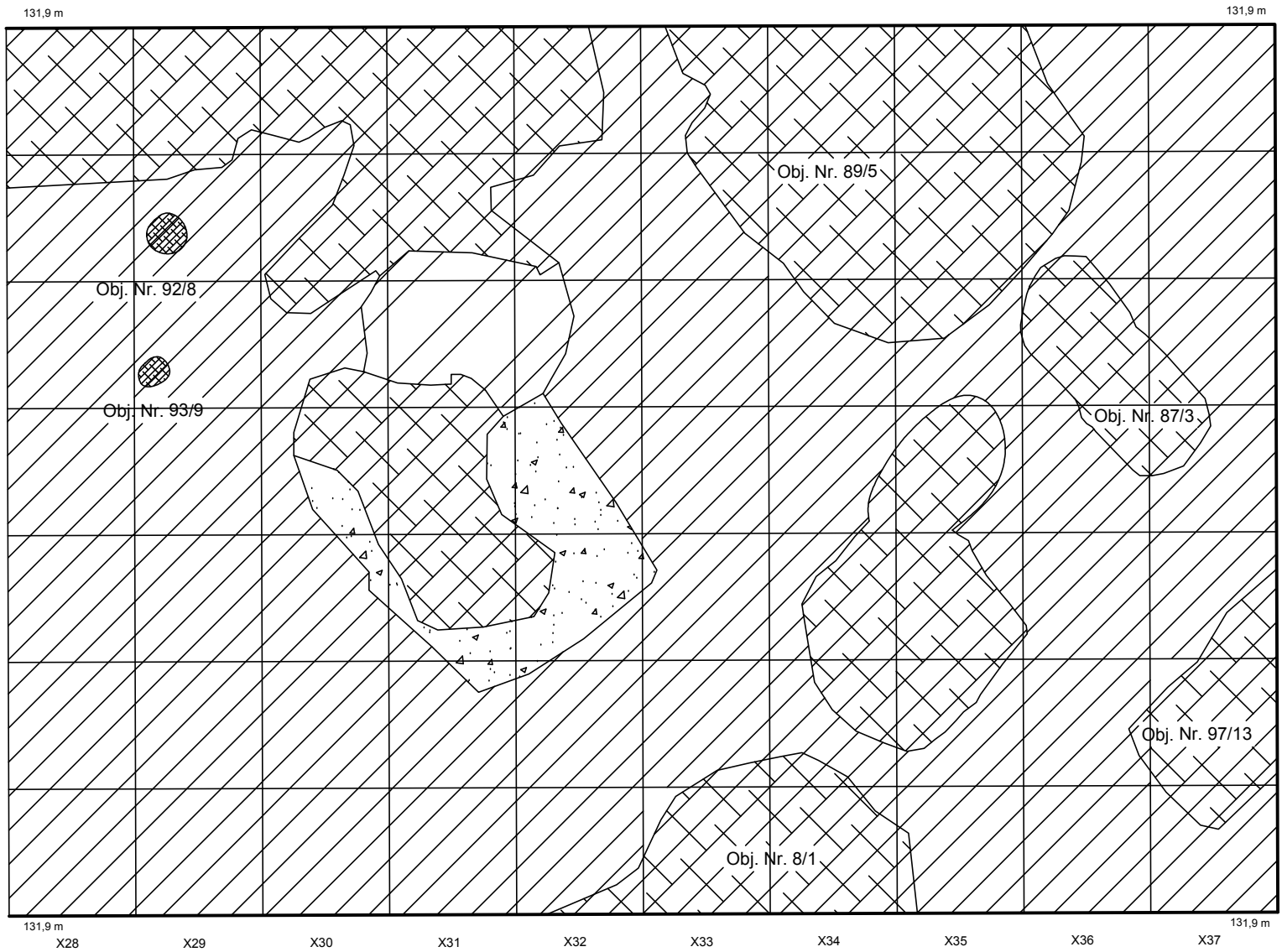

P-17 t. p. ž. sluoksnio (XV a.) sit. planas (1-1,1 m gylis)	
M1:50	
Brėžinys Nr. 62	72

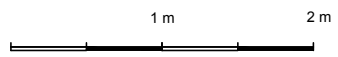
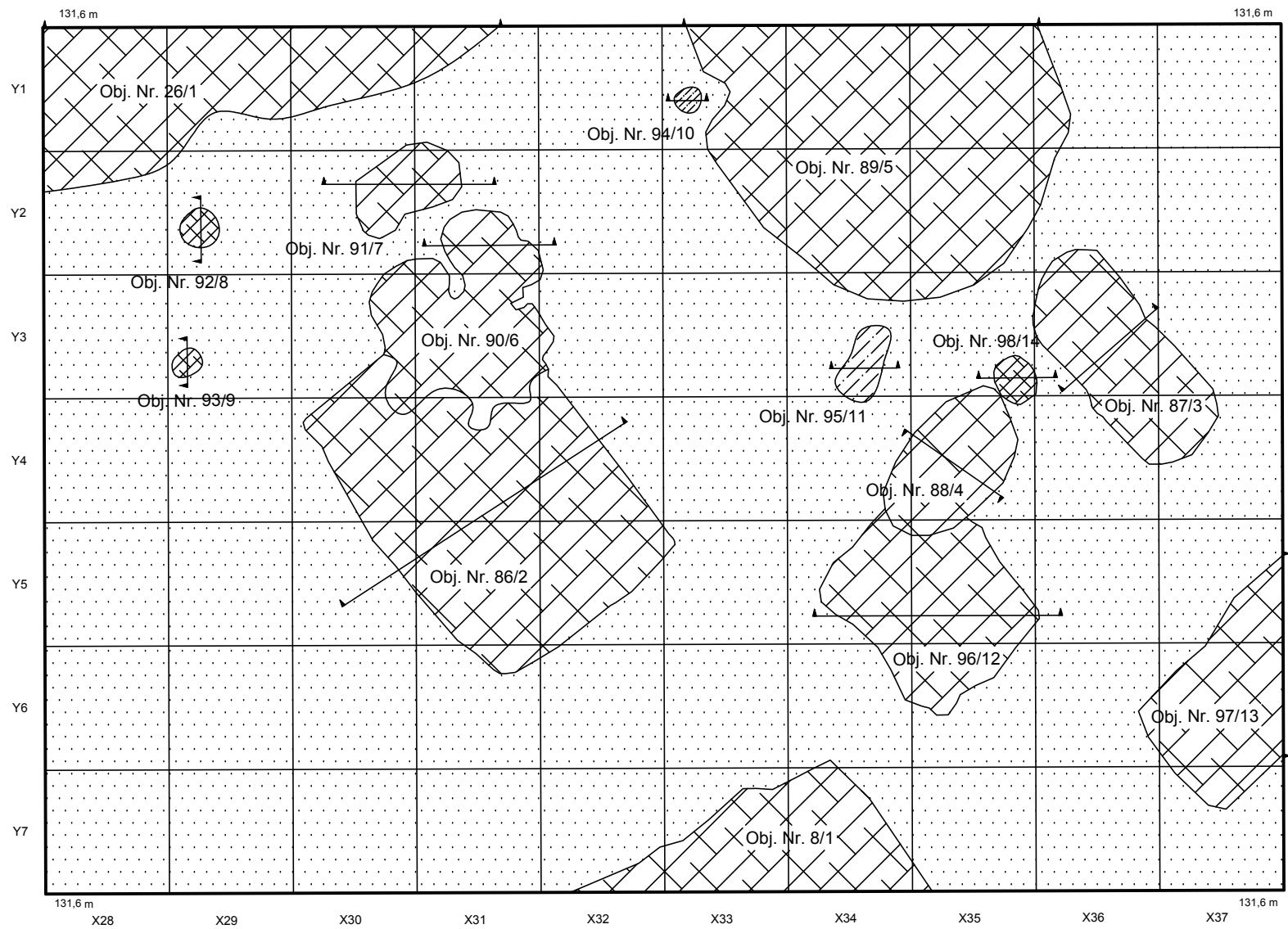

P-17 obj. sit. planas žemyje (1,2 m gylis)
M1:50
Brėžinys Nr. 63

P-15 P sienos pjūvis

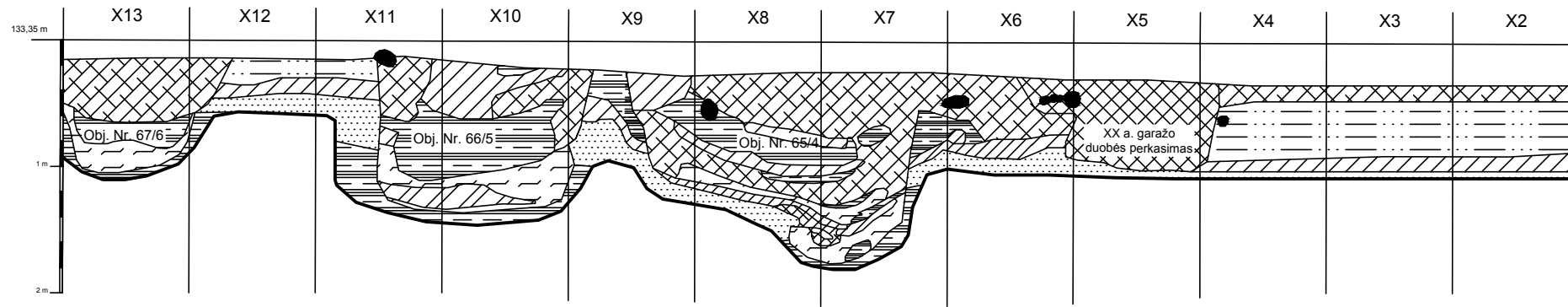

P-16 Š sienos pjūvis

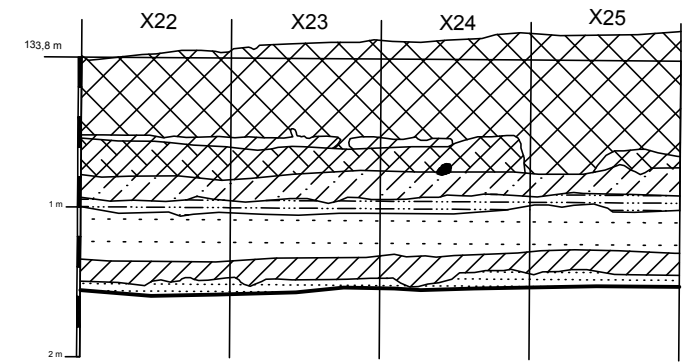

P-15 ŠV sienos pjūvis (KV. Y27-Y19)

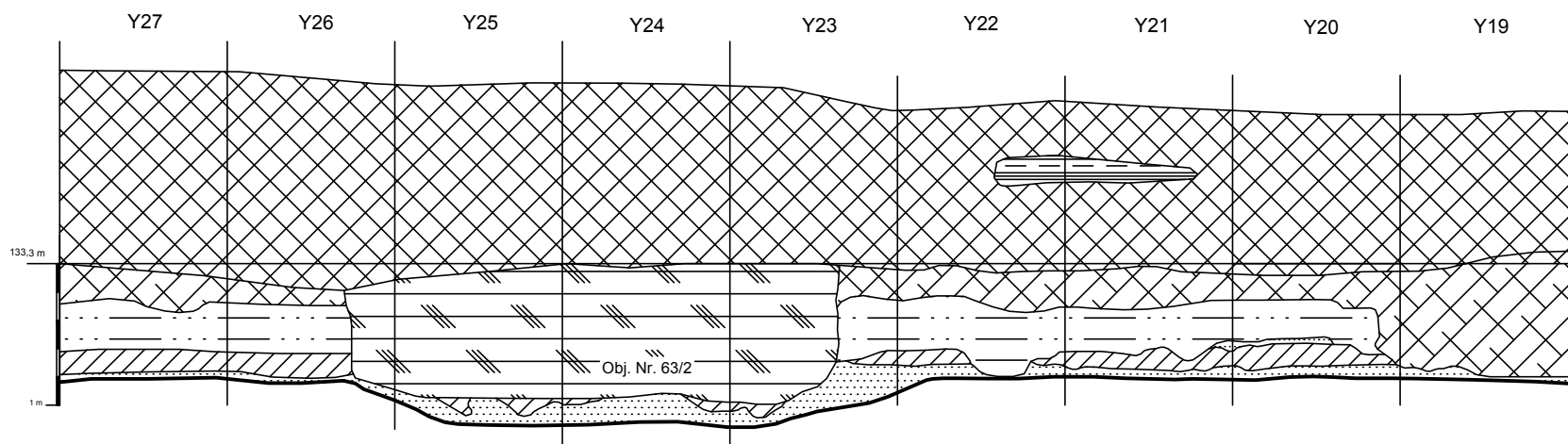

P-16 V sienos pjūvis

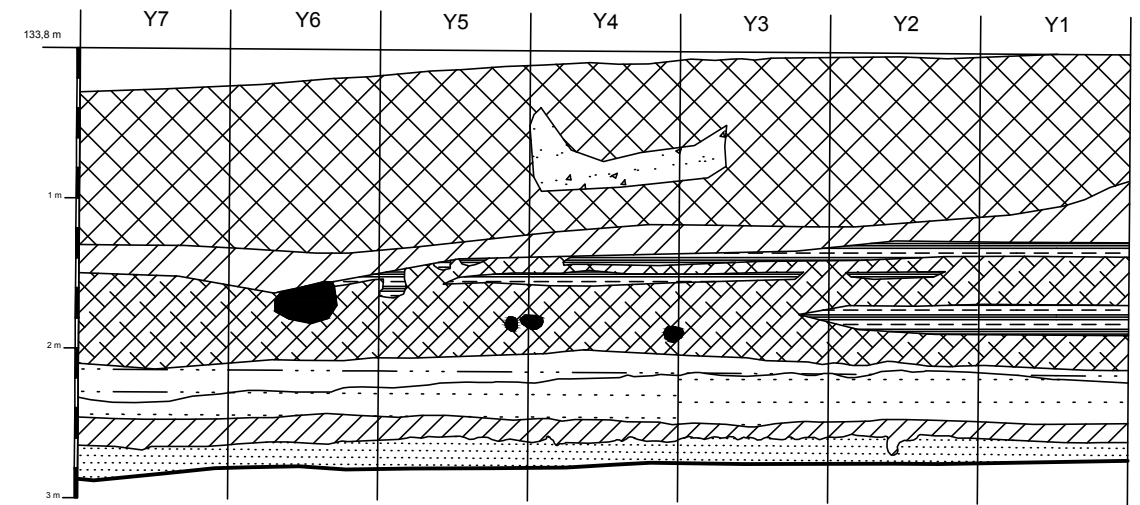

P-17 Š sienos pjūvis

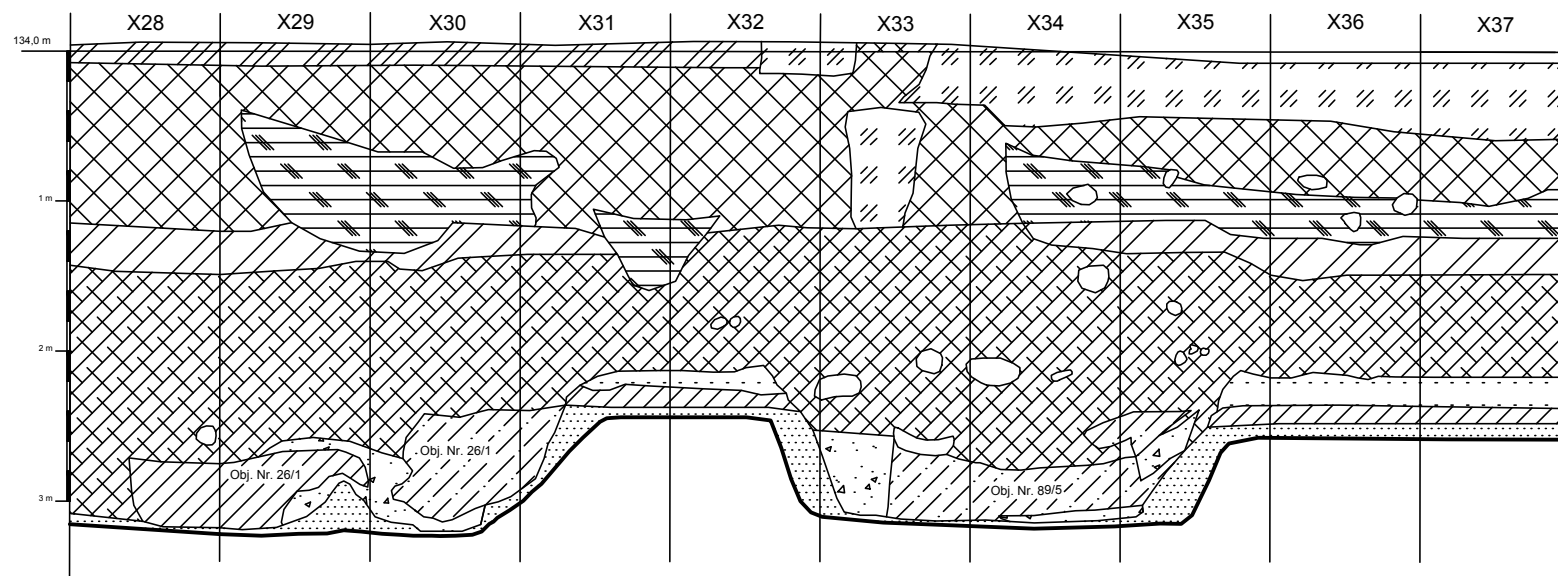

P-17 R sienos pjūvis

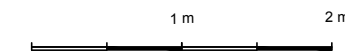
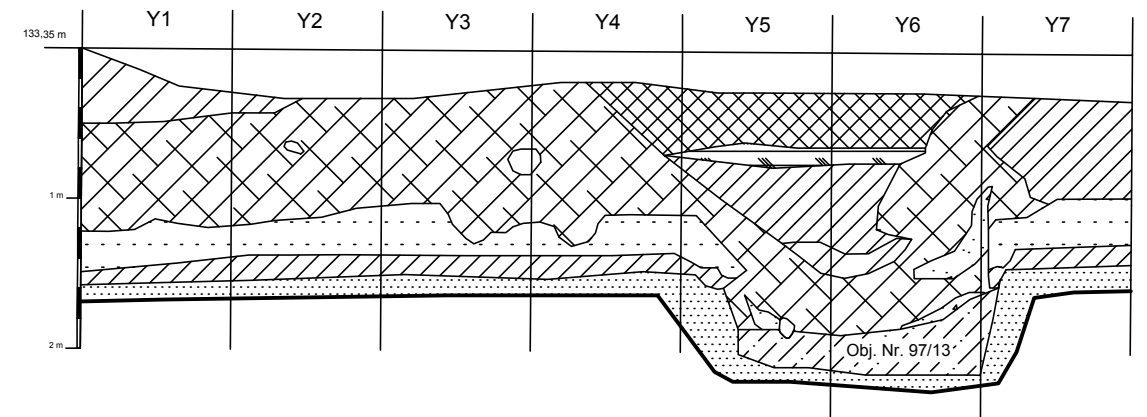

P-15 P sienos pjūvis;  
 P-15 ŠV sienos pjūvis (KV. Y27-Y19);  
 P-16 Š, V sienų pjūviai;  
 P-17 Š, R sienų pjūviai

M1:40

Brėžinys Nr. 64

Kv. X38–X48/Y1 1 m pločio laiptas

132,8 m

132,8 m

Y1

Y2

Y3

Y4

Y5

Y6

Y7

betono  
lūptas

133,3 m

Gyvenamojo namo  
Nr. P2 fragm.

132,8 m

X38

X39

X40

X41

X42

X43

X44

X45

X46

X47

X48

132,85 m

1 m

2 m



P–18 sit. planas (0,2 m gylis)

M1:50

Brėžinys Nr. 65

131,8 m

Kv. X38–X48/Y1 1 m pločio laiptas

131,8 m

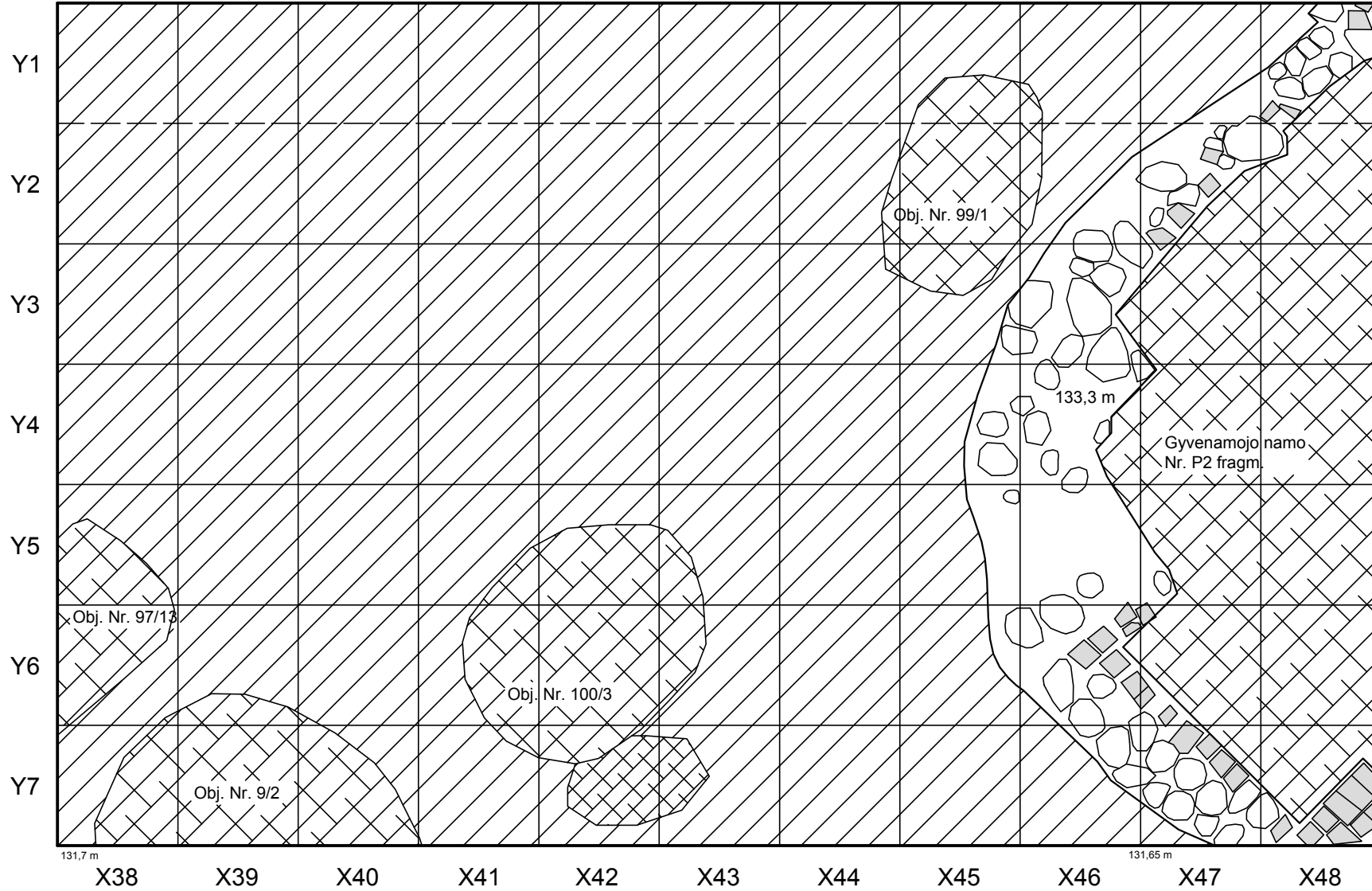

131,7 m

X38

X39

X40

X41

X42

X43

X44

X45

X46

X47

X48

131,65 m

1 m

2 m



P–18 t. p. ž. sluoksniu (XV a.) sit. planas (0,9–1 m gylis)

M1:50

Brėžinys Nr. 66

132,5 m

Kv. X38–X48/Y1 1 m pločio laiptas

132,5 m

Y1

Y2

Y3

Y4

Y5

Y6

Y7



Obj. Nr. 99/1

133,3 m

Gyvenamojo namo  
Nr. P2 fragm.

Obj. Nr. 97/13

Obj. Nr. 100/3

Obj. Nr. 9/2

132,5 m

X38

X39

X40

X41

X42

X43

X44

X45

X46

X47

X48

132,5 m

1 m

2 m



P-18 obj. sit. planas įžemyje (1–1,15 m gylis)

M1:50

Brėžinys Nr. 67

P-18 Š sienos pjūvis

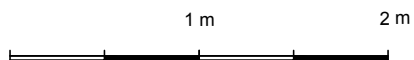
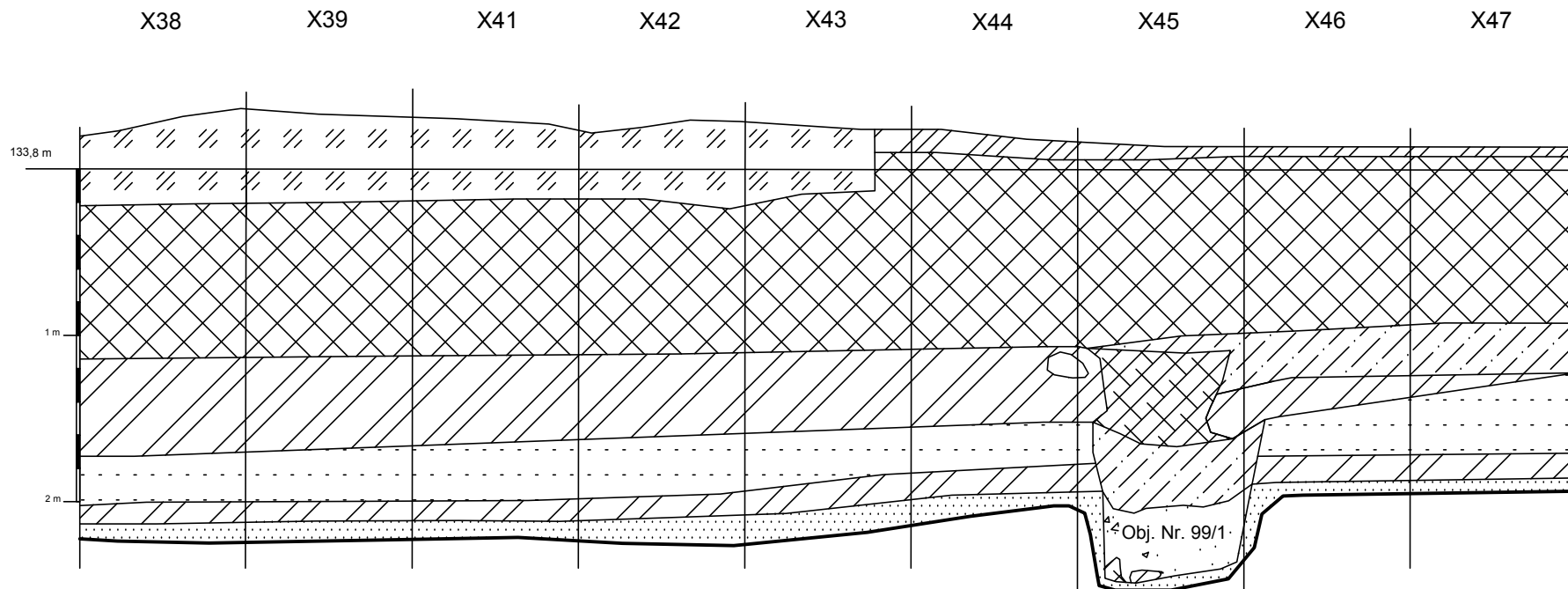

P-18 Š sienos pjūvis

M1:40

Brēžinys Nr. 68

Obj. Nr. 83/1

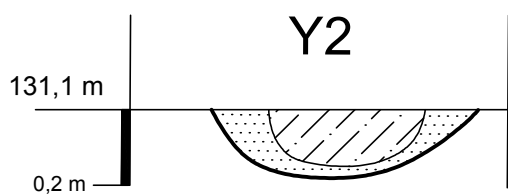

Obj. Nr. 84/2

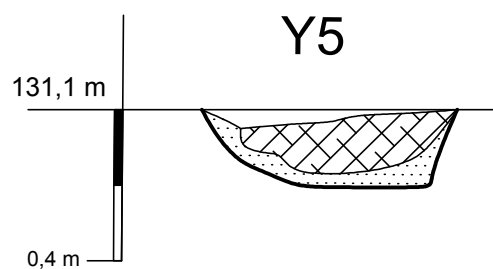

Obj. Nr. 85/3

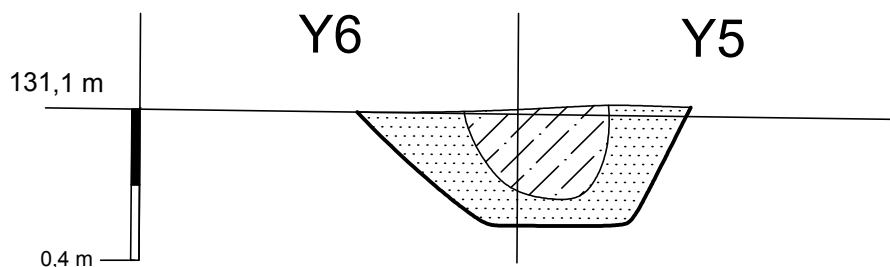

Obj. Nr. 86/2

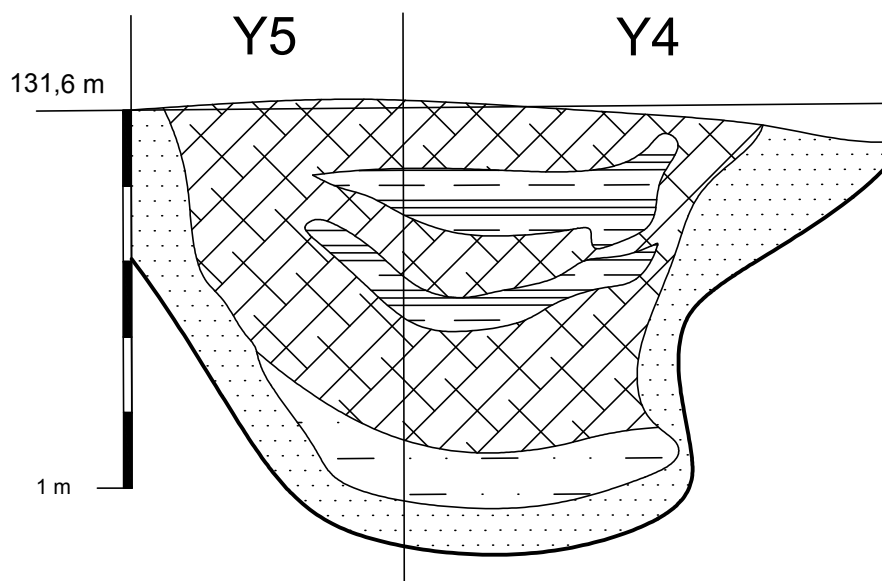

Obj. Nr. 83/1–86/2

M1:20

Brėžinys Nr. 69



Obj. Nr.87/3

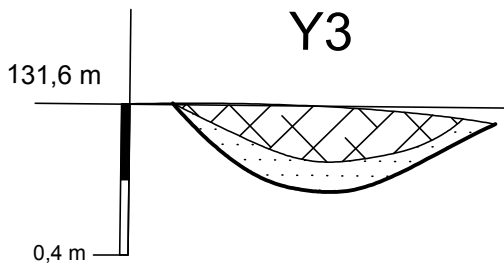

Obj. Nr.88/4

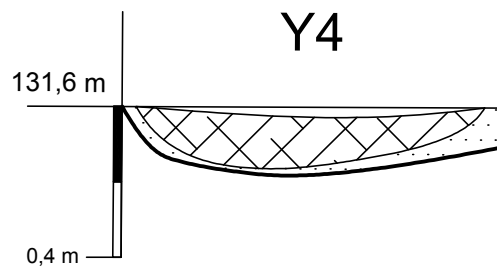

Obj. Nr. 91/7

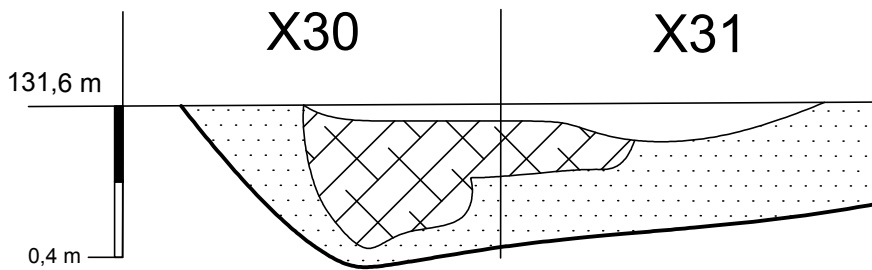

Obj. Nr.90/6

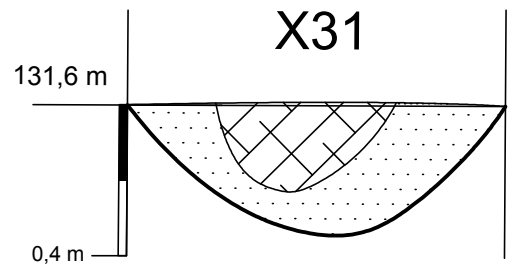

Obj. Nr. 92/8

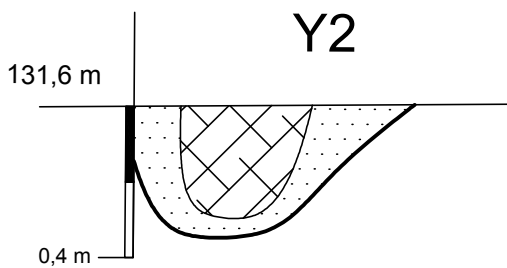

Obj. Nr. 93/9

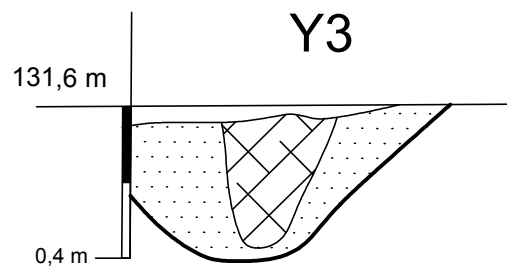

Obj. Nr. 94/10

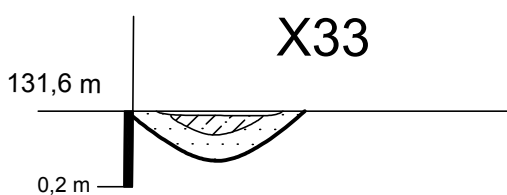

Obj. Nr. 87/3–94/10

M1:20

Brėžinys Nr. 70

Obj. Nr. 95/11

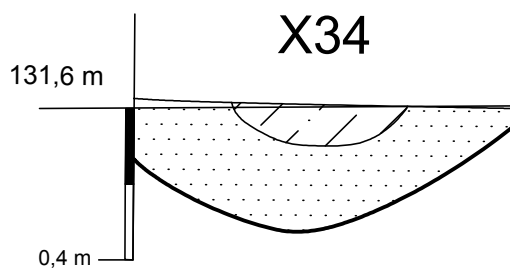

Obj. Nr. 98/14

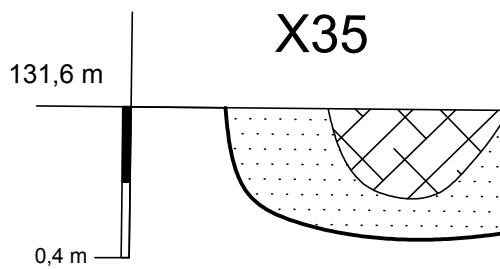

Obj. Nr. 96/12

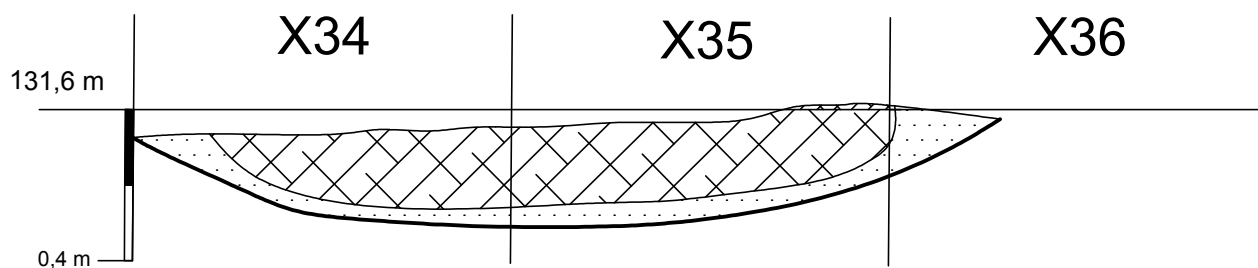

Obj. Nr. 100/3

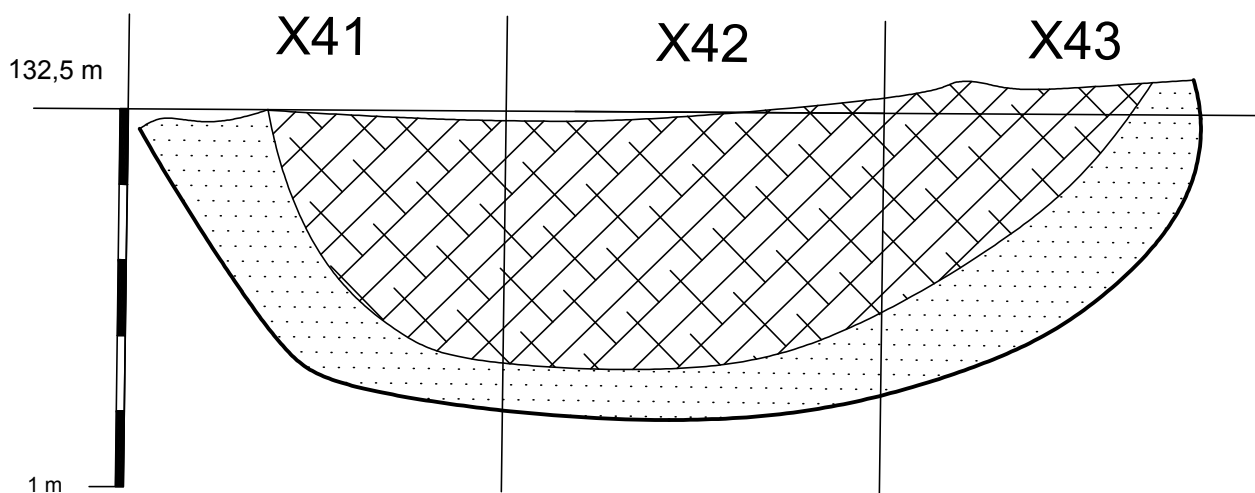

Obj. Nr. 95/11–96/12, 98/14, 100/3

M1:20

Brėžinys Nr. 71

Kv. X51–X63/Y1 1 m pločio laiptas

133,3 m

133,65 m

Y1

Y2

Y3

Y4

Y5

Y6

Y7

Gyvenamojo namo  
Nr. P2 fragm.

133,1 m

XX a. perkasimas

XX a. perkasimas

133,3 m

Kv. X51–X63/Y7 0,5 m pločio kontrolinė juosta

133,65 m

X51

X52

X53

X54

X55

X56

X57

X58

X59

X60

X61

X62

X63

1 m

2 m

P–19 sit. planas (0,2 m gylis)

M1:50

Brėžinys Nr. 72

132,5 m Kv. X51–X63/Y1 1 m pločio laiptas

132,9 m



Y1  
Y2  
Y3  
Y4  
Y5  
Y6  
Y7

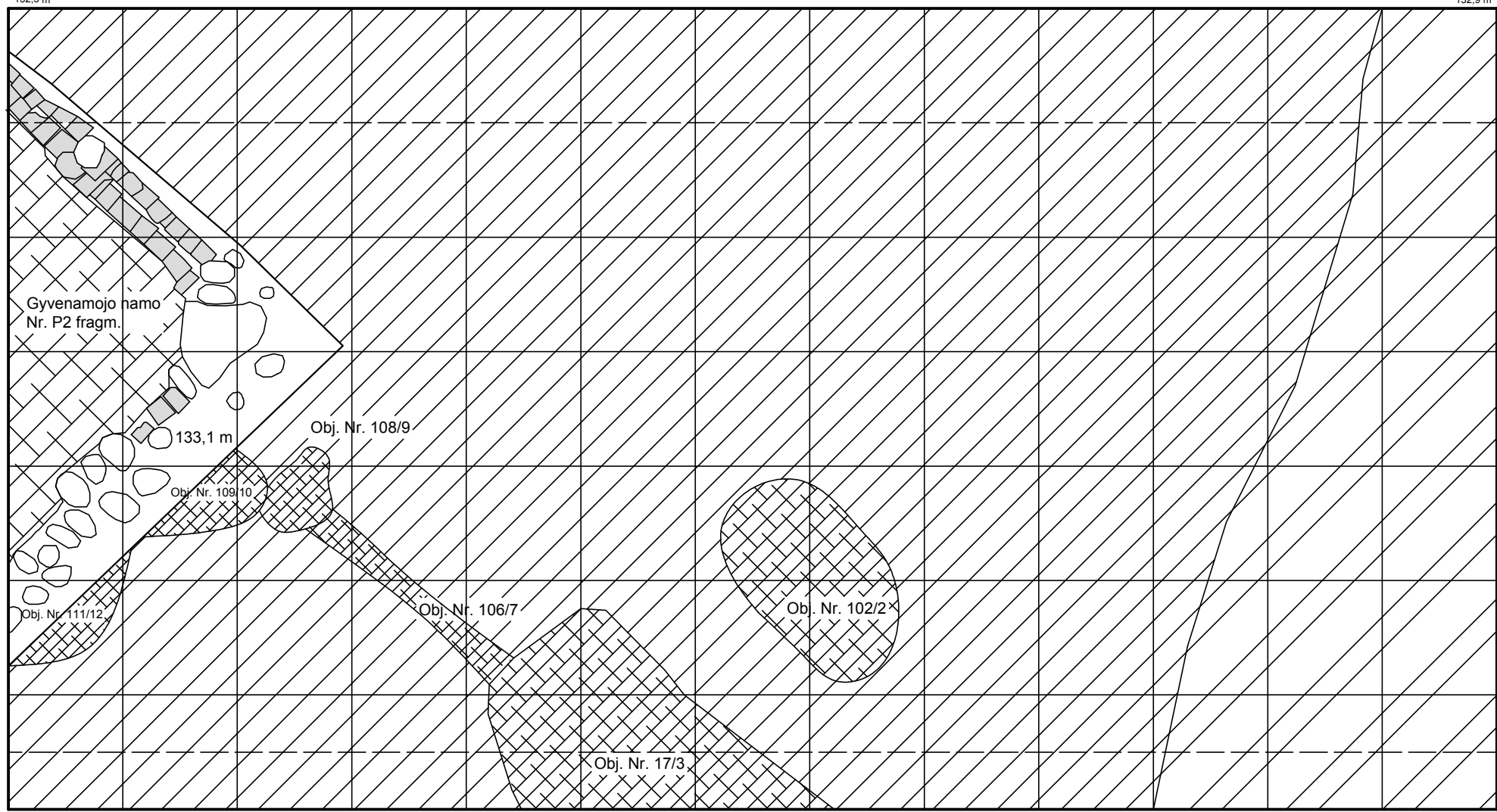

132,5 m Kv. X51–X63/Y7 0,5 m pločio kontrolinė juosta

132,9 m

X51 X52 X53 X54 X55 X56 X57 X58 X59 X60 X61 X62 X63

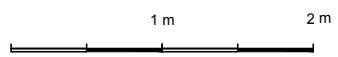

P–19 t. p. ž. sluoksniu (XV a.) sit. planas (0,5–1,3 m gylis)
M1:50
Brėžinys Nr. 73

Kv. X51–X63/Y1 1 m pločio laiptas

132,8 m

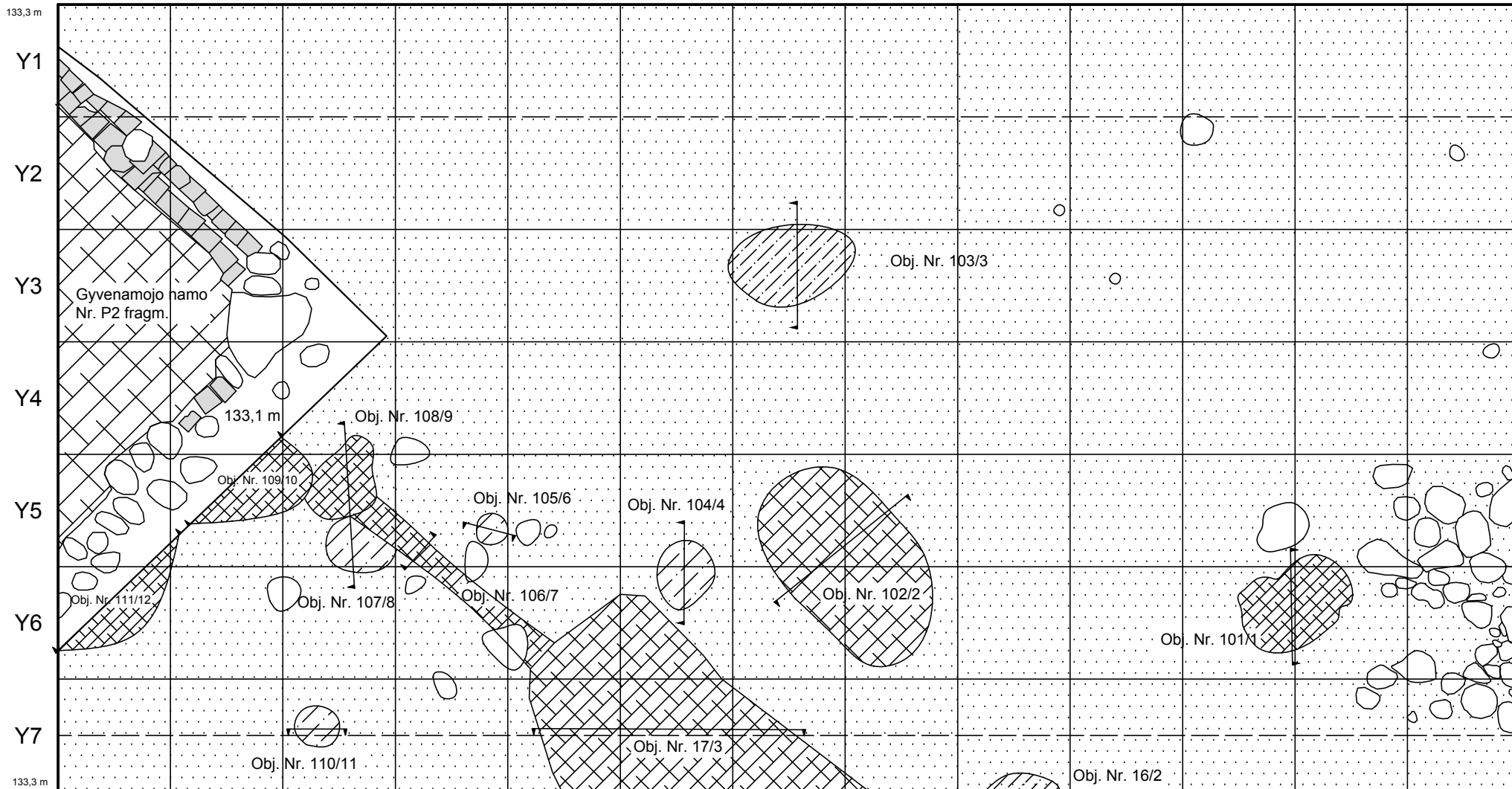

Y1

Y2

Y3

Y4

Y5

Y6

Y7

133,3 m

133,3 m

Kv. X51–X63/Y7 0,5 m pločio kontrolinė juosta

132,8 m

X51

X52

X53

X54

X55

X56

X57

X58

X59

X60

X61

X62

X63

1 m

2 m

P–19 obj. sit. planas žemyje (0,55–1,4 m gylis)

M1:50

Brėžinys Nr. 74

Obj. Nr. 101/1

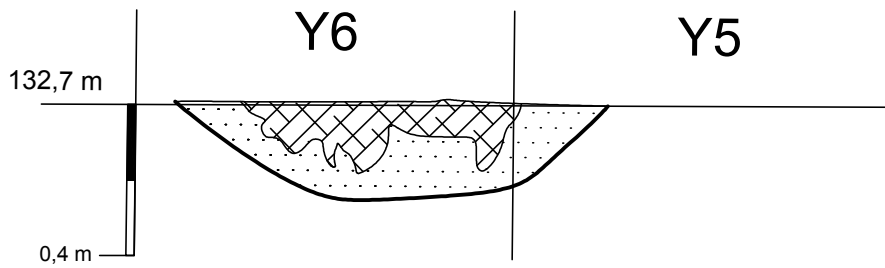

Obj. Nr. 102/2

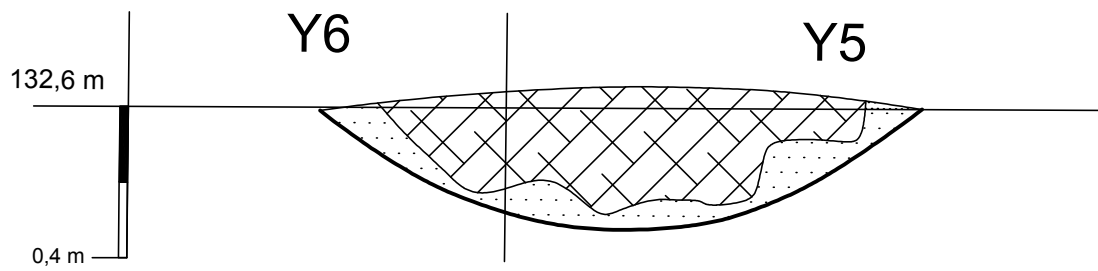

Obj. Nr. 103/3

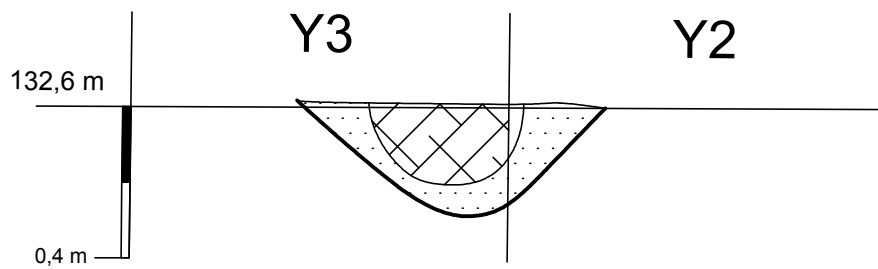

Obj. Nr. 101/1–103/3

M1:20

Brėžinys Nr. 75

Obj. Nr. 104/4

Obj. Nr. 105/6

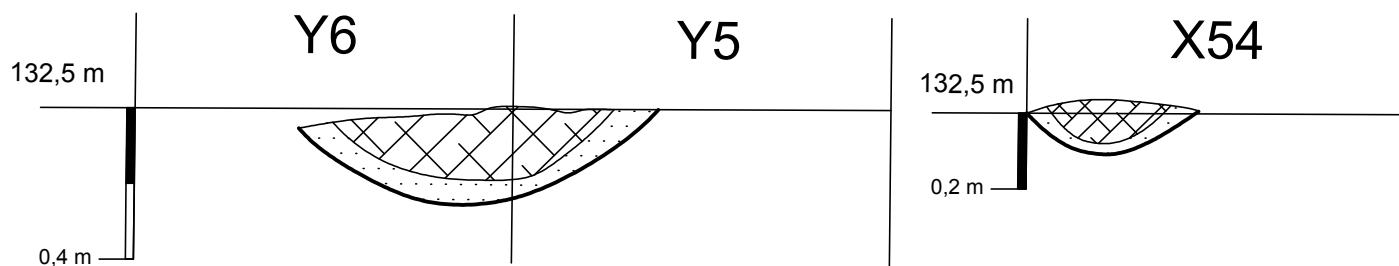

Obj. Nr. 106/7

Obj. Nr. 107/8

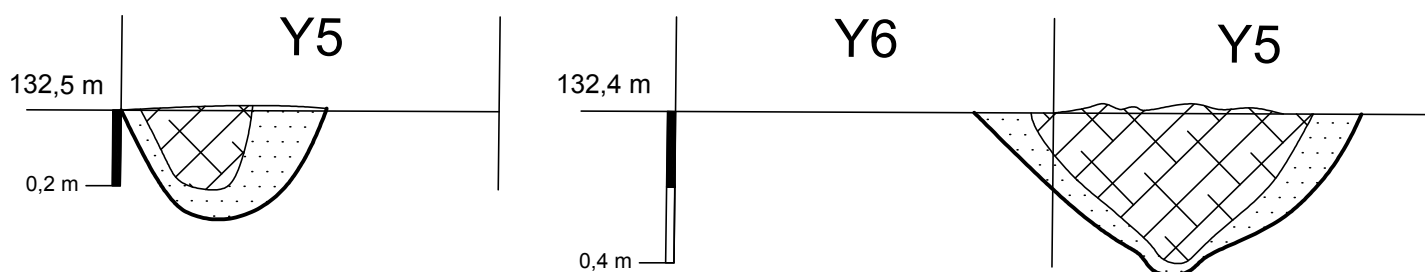

Obj. Nr. 108/9

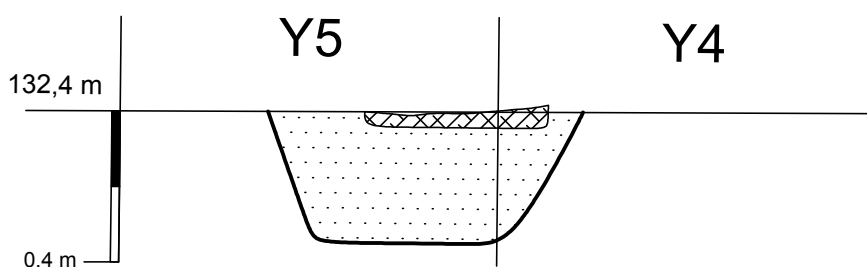

Obj. Nr. 104/4–108/9

M1:20

Brėžinys Nr. 76

Obj. Nr. 109/10

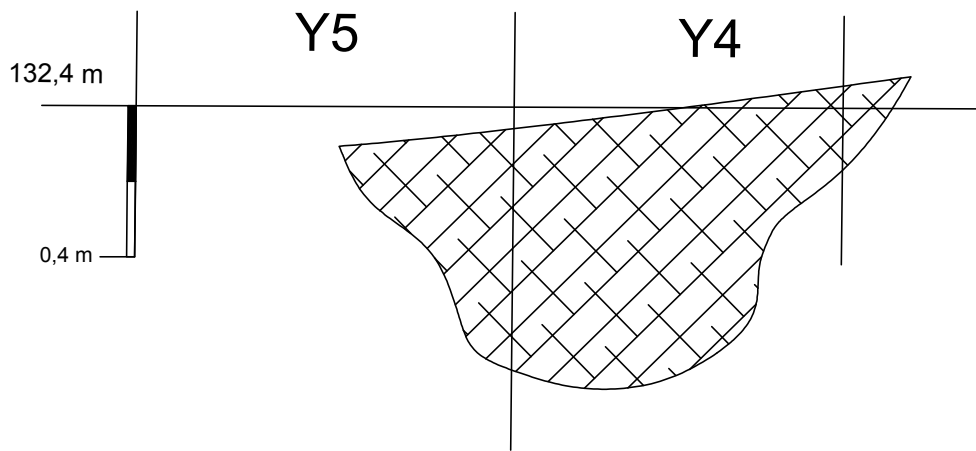

Obj. Nr. 111/12

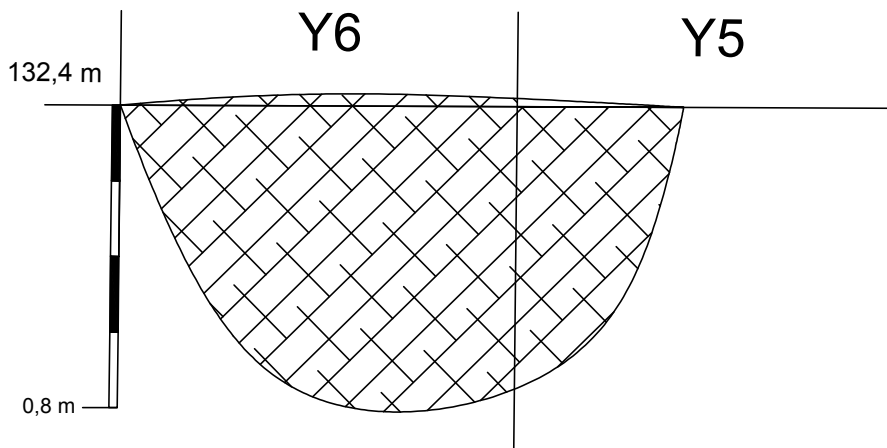

Obj. Nr. 109/10, 111/12

M1:20

Brėžinys Nr. 77



P-19 Š sienos pjūvis

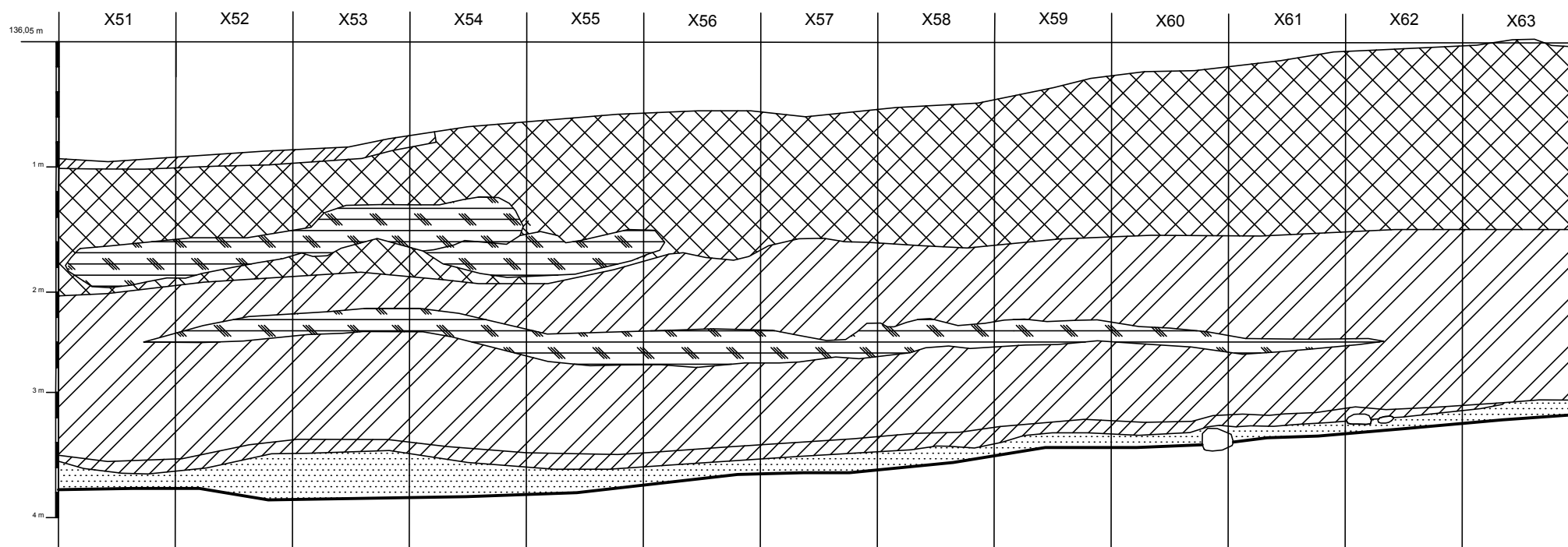

P-19 R sienos pjūvis

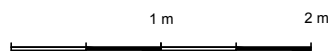
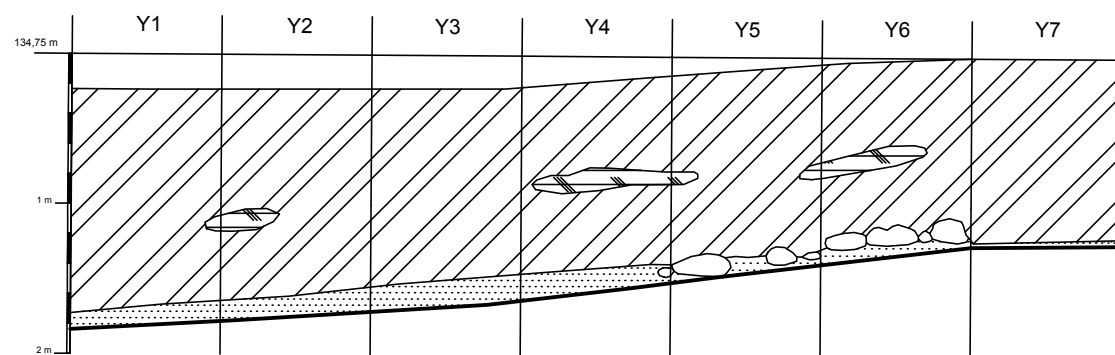

P-19 P sienos pjūvis

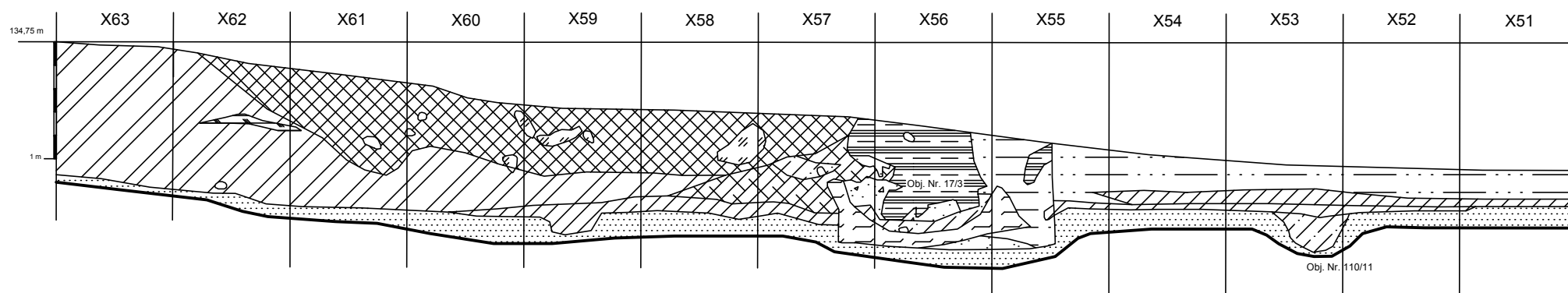

P-19 Š, R, P sienų pjūviai

M1:40

Brėžinys Nr. 78

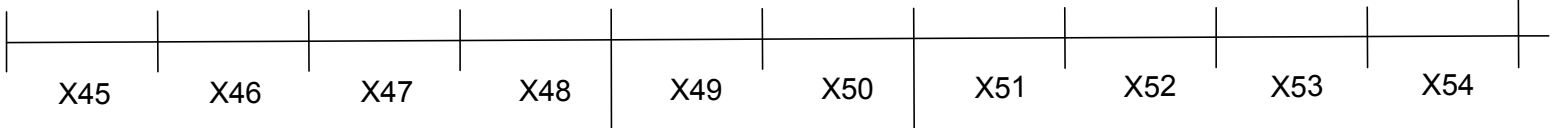
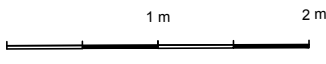
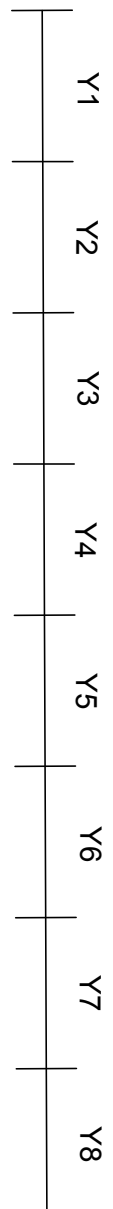
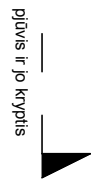
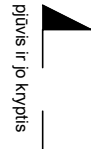

P-18

P-7

P-19

Gyvenamojo namo Nr. P2 fragm. planas
M1:40
Brėžinys Nr. 79

### Gyvenamojo namo Nr. P2 rūšio Š siena

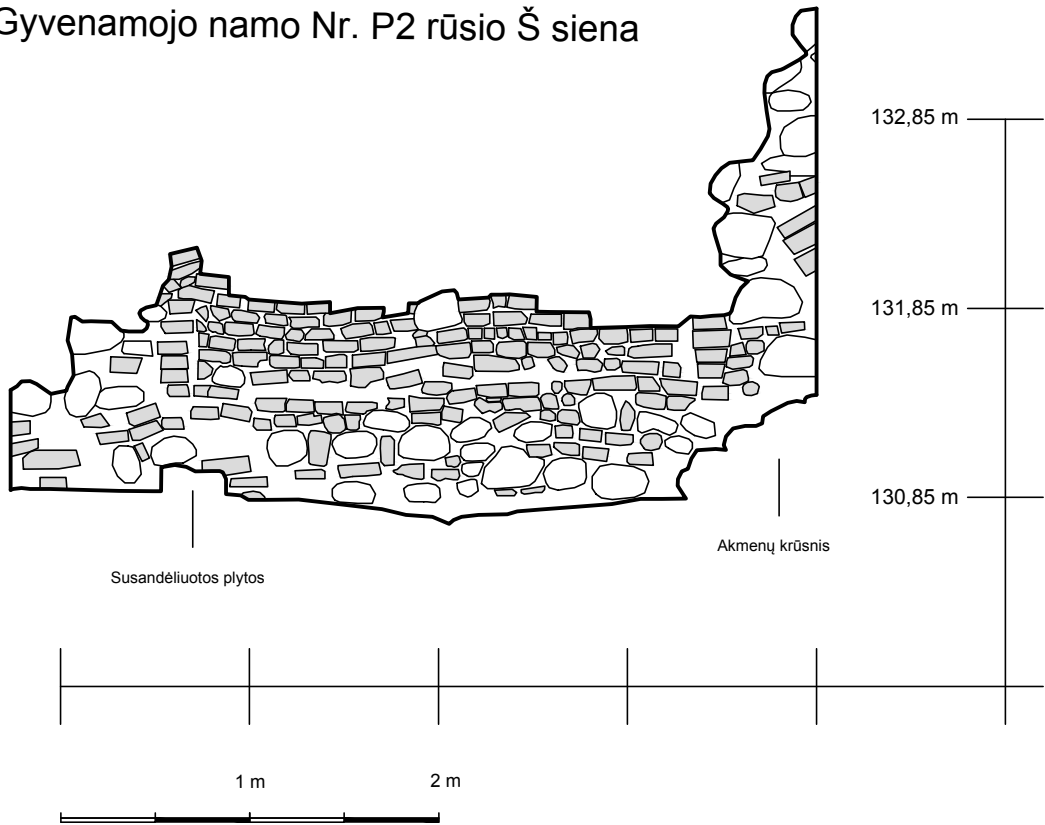

### Gyvenamojo namo Nr. P2 rūšio R siena

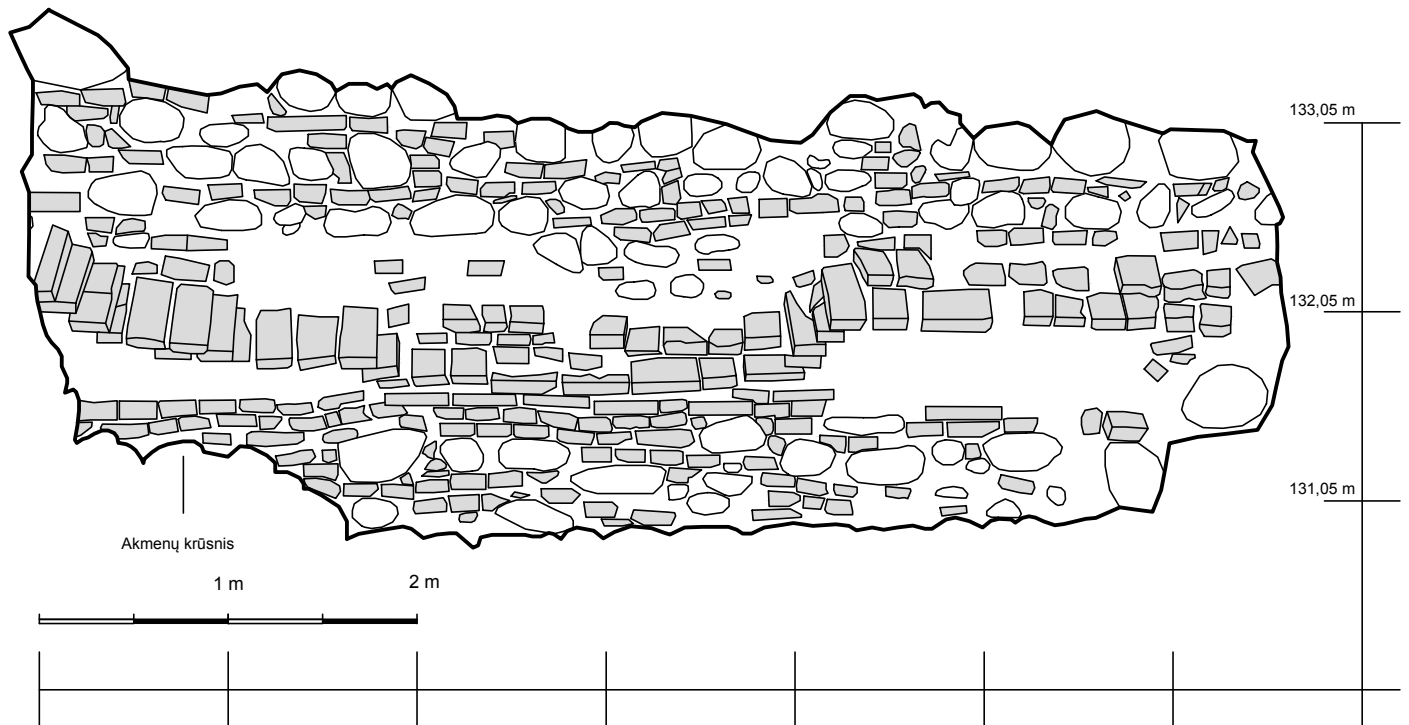

Gyvenamojo namo Nr. P2 rūšio Š, R sienos

M1:40

Brėžinys Nr. 80

### Gyvenamojo namo Nr. P2 rūsio P siena

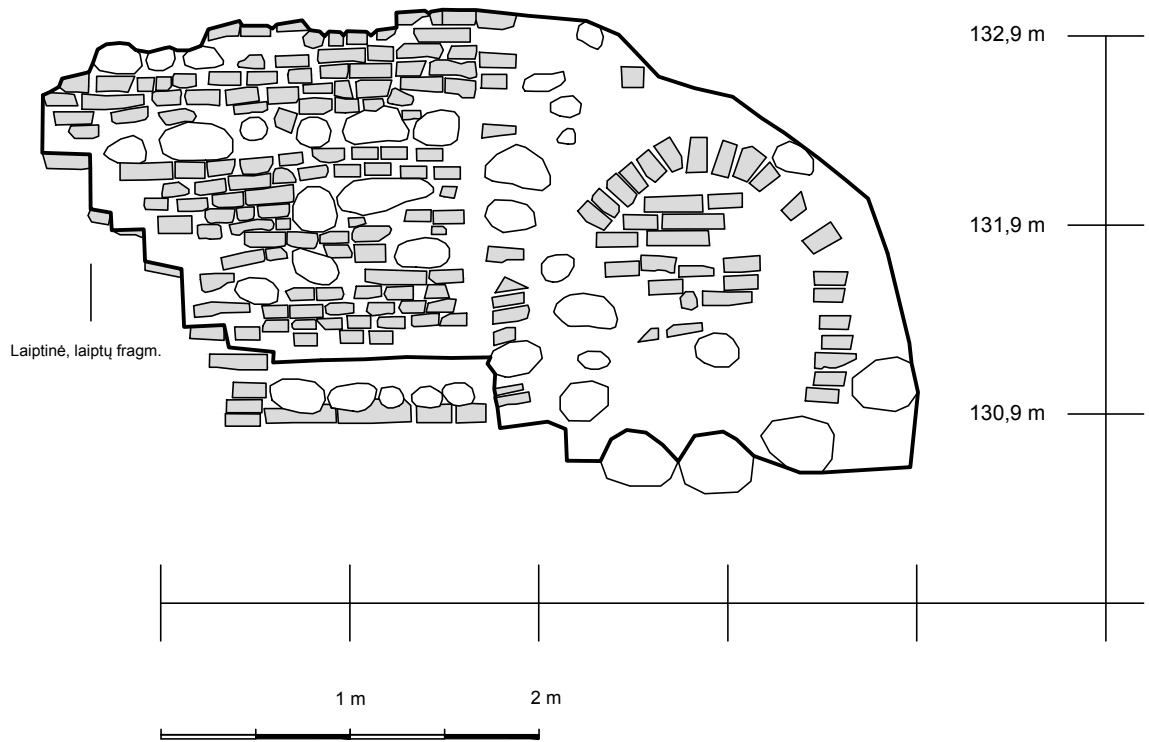

### Gyvenamojo namo Nr. P2 rūsio V siena

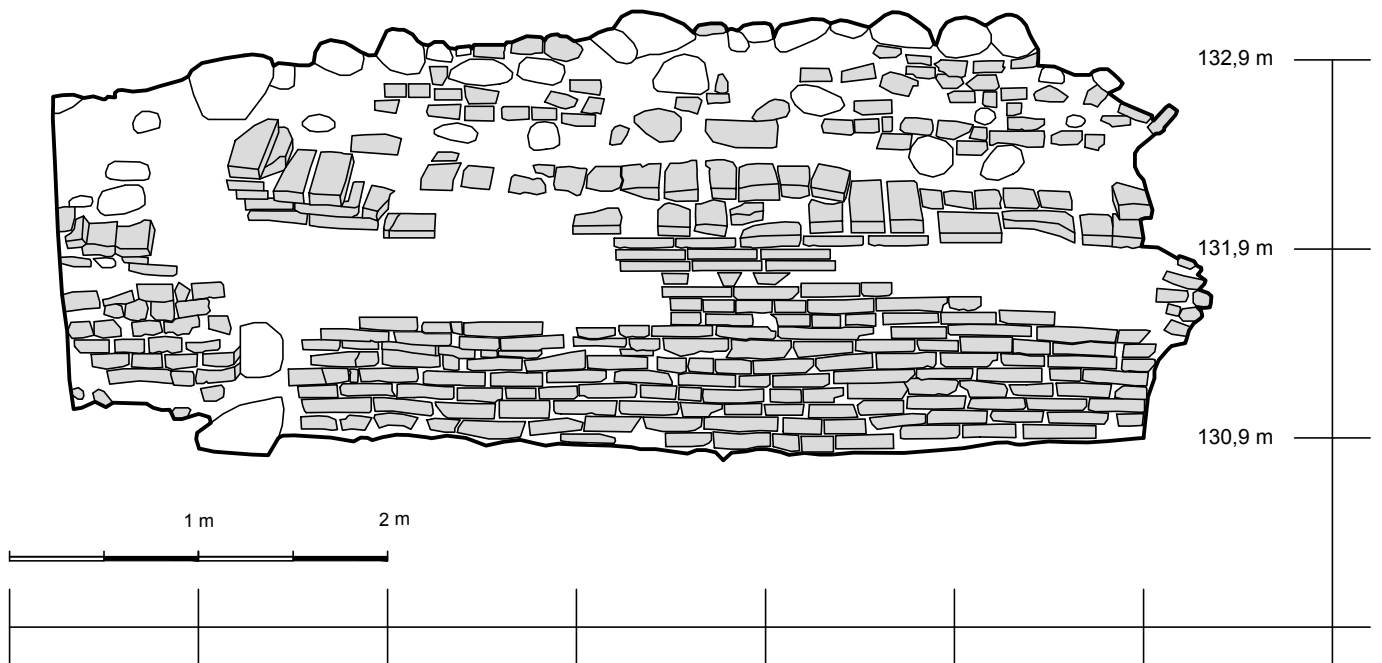

Gyvenamojo namo Nr. P2 rūsio P, V sienos

M1:40

Brėžinys Nr. 81

P-20 sit. planas (0,2 m gylis)

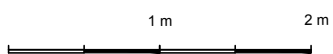
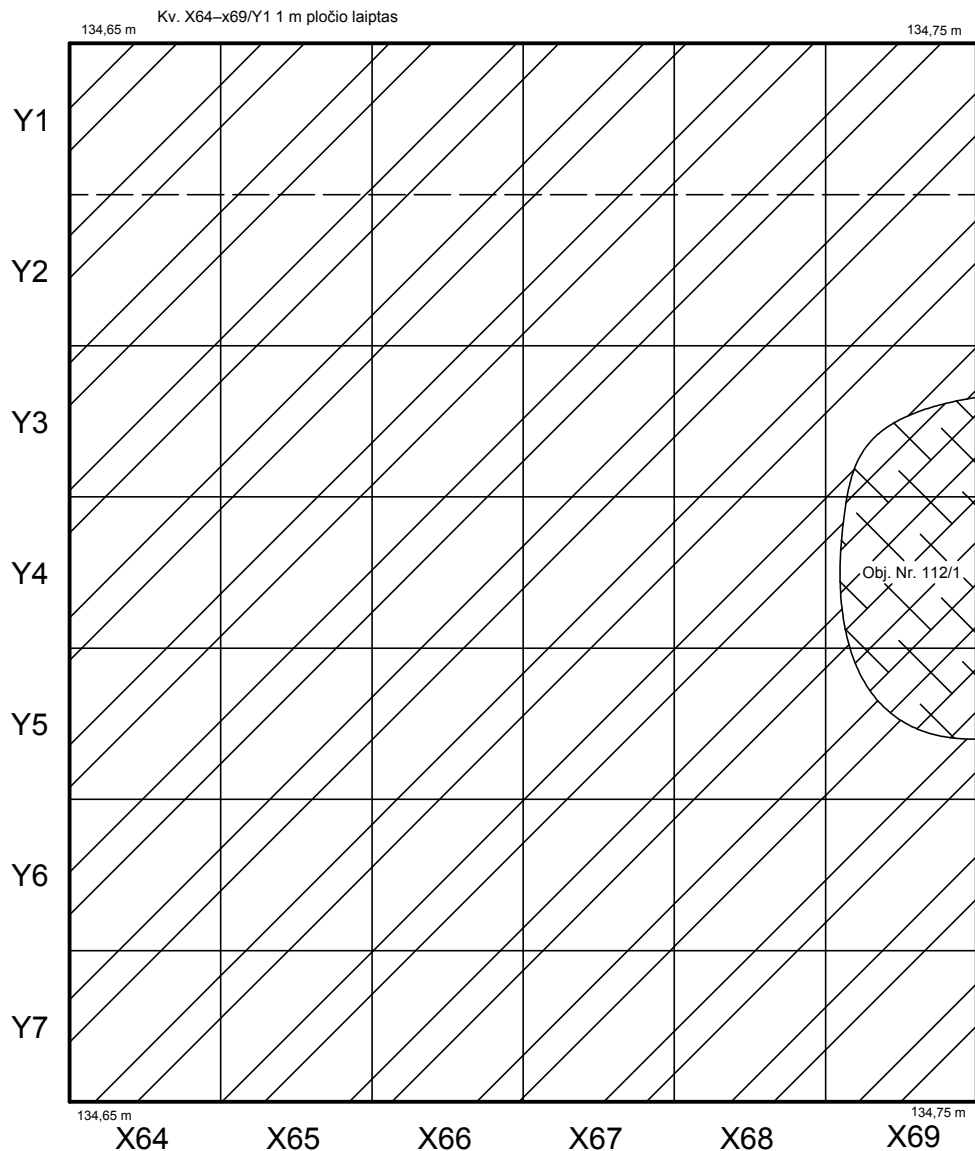

P-20 obj. sit. planas įžemyje (0,8-1 m gylis)

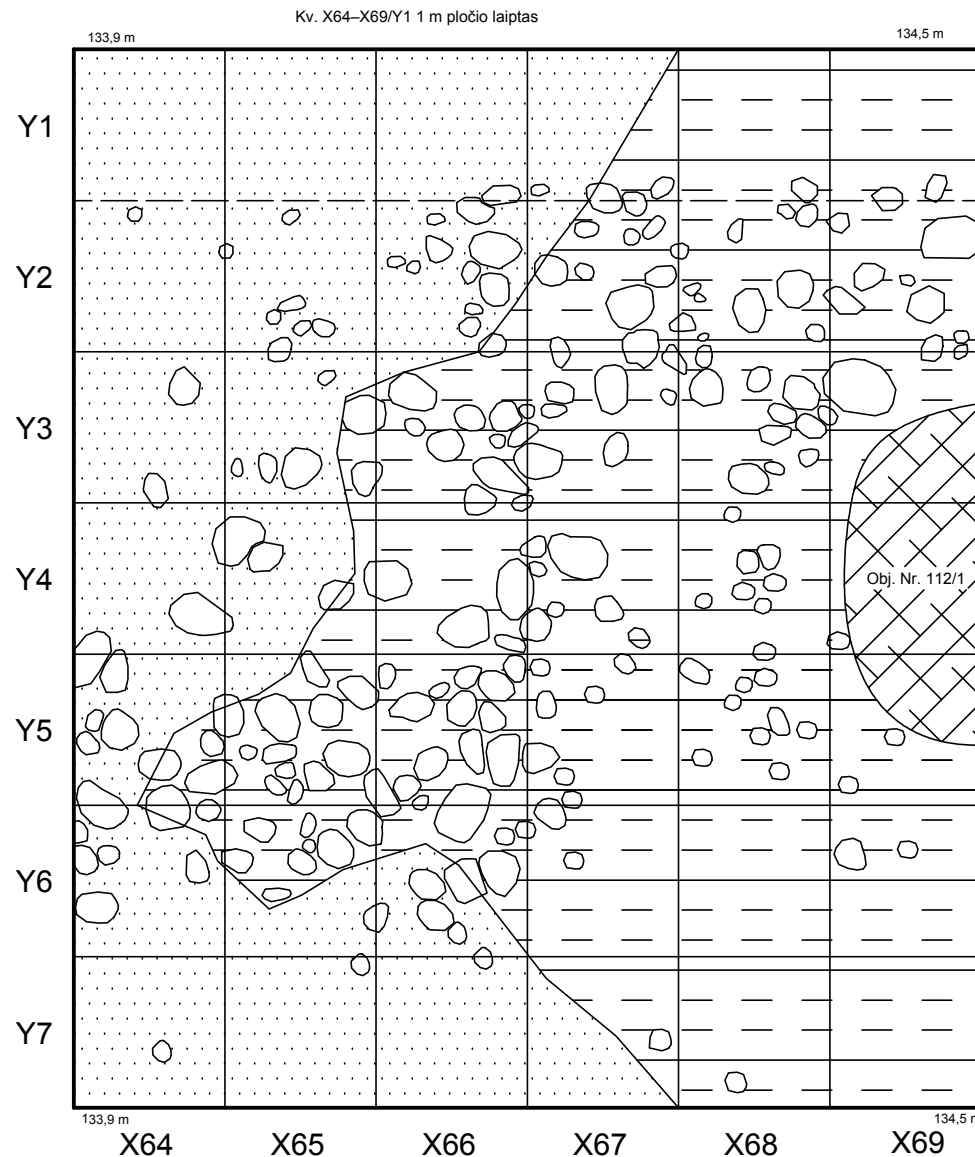

P-20 sit. planas (0,2 m gylis);  
P-20 obj. sit. planas įžemyje (0,8-1 m gylis)

M1:50

Brėžinys Nr. 82

P-20 Š sienos pjūvis

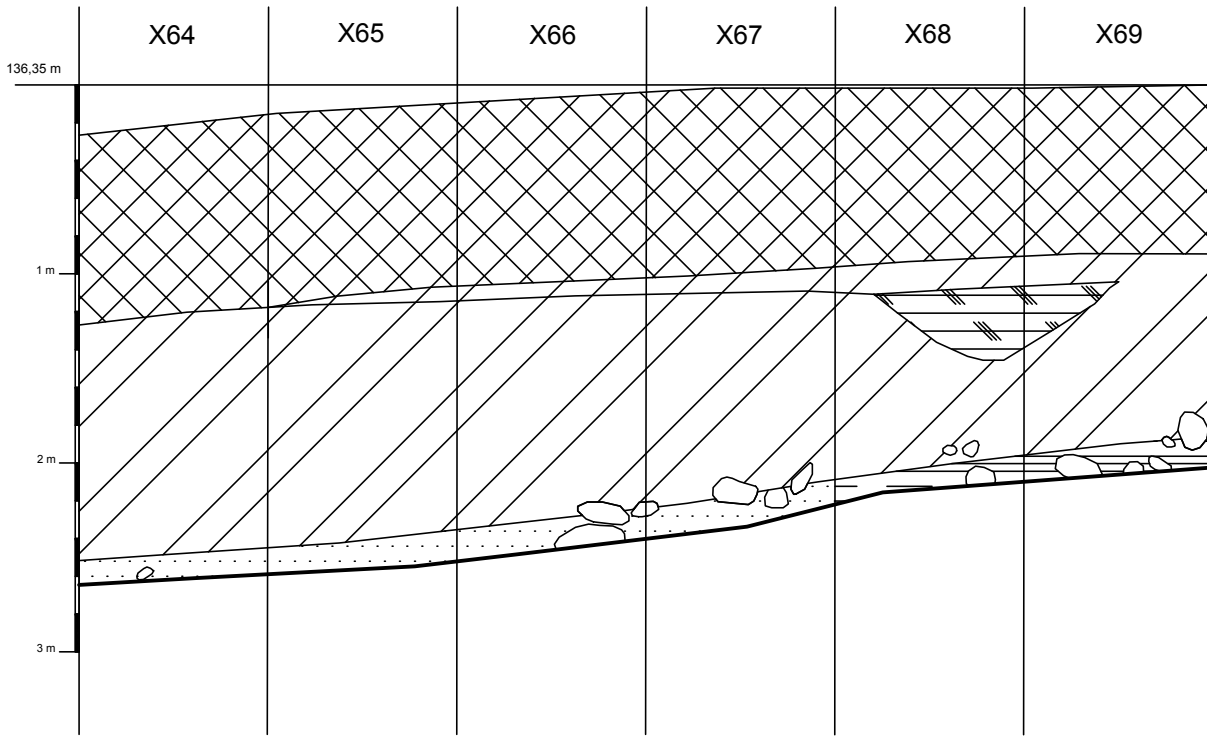

P-20 R sienos pjūvis

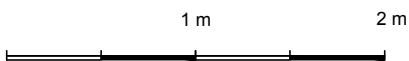
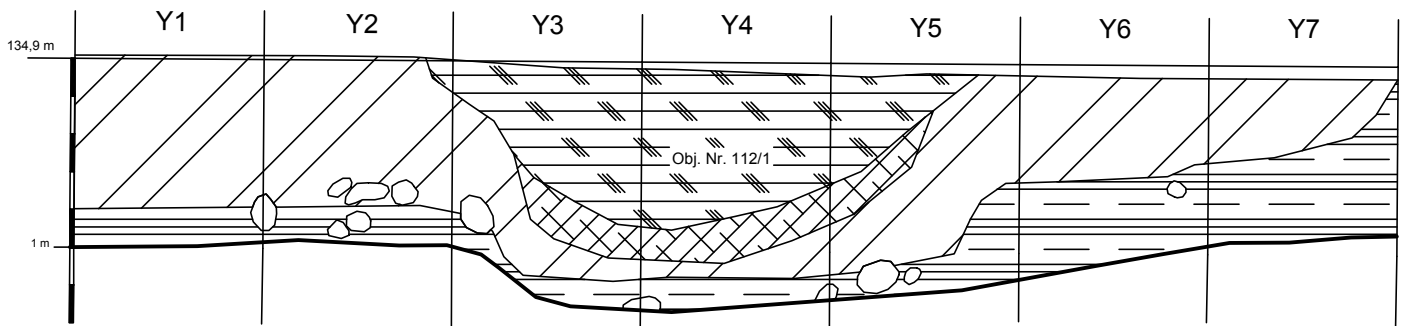

P-20 Š, R sienų pjūviai

M1:40

Brėžinys Nr. 83

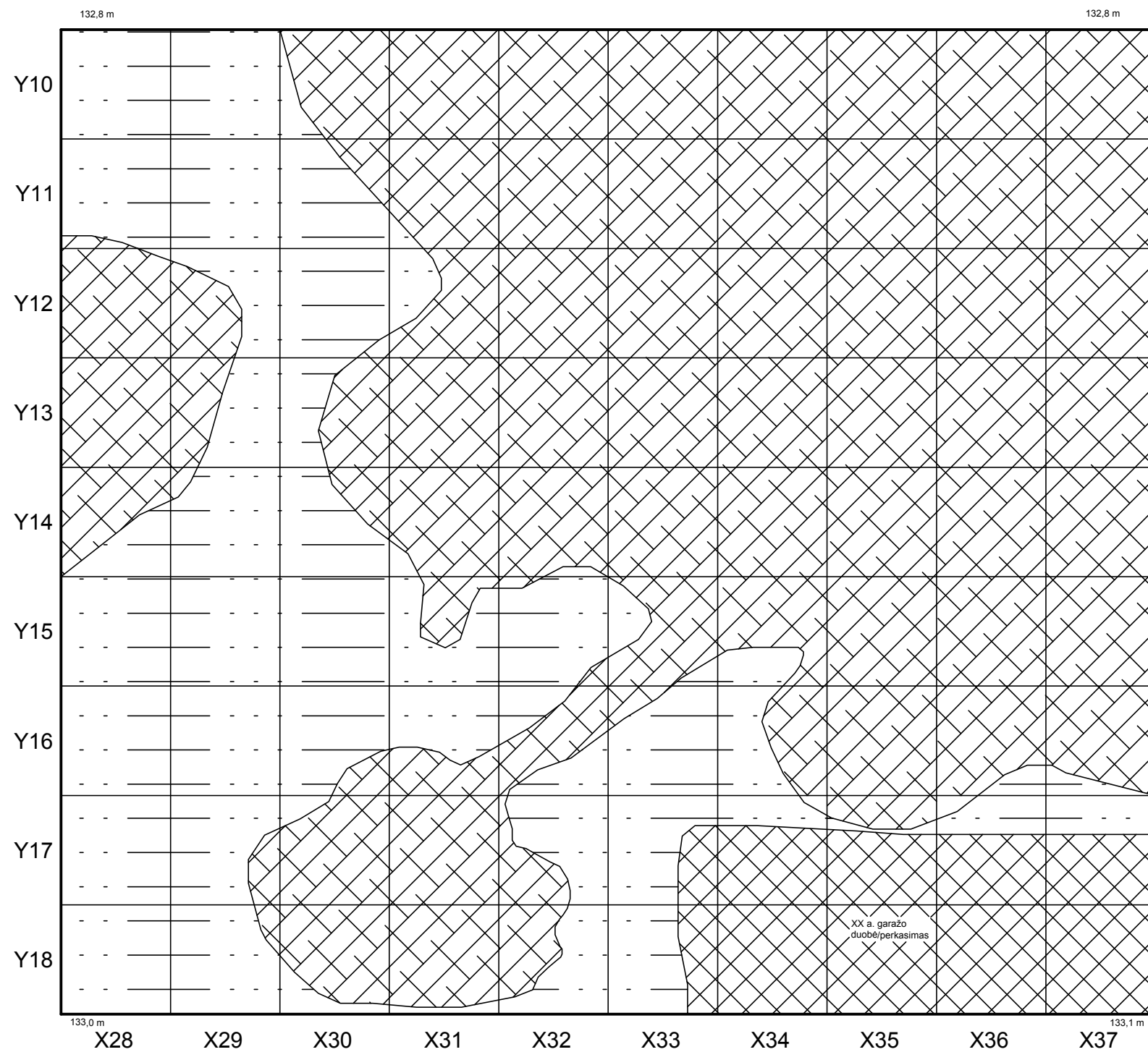

P-21 sit. planas (0,2 m gylis)
M1:50
Brėžinys Nr. 84

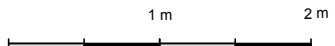
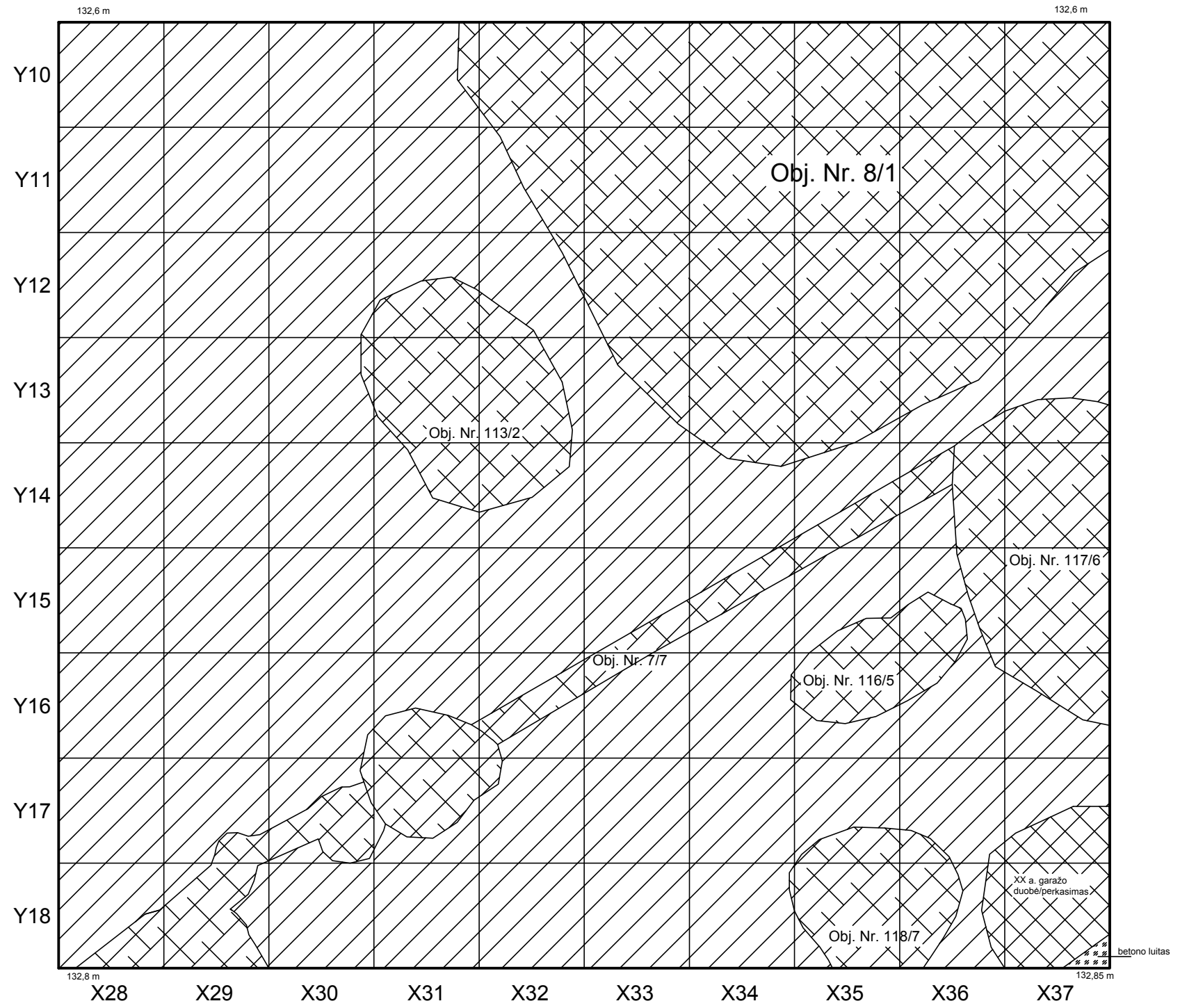

P-21 t. p. ž. sluoksniu (XV a.) sit. planas (0,6 m gylis)
M1:50
Brėžinys Nr. 85



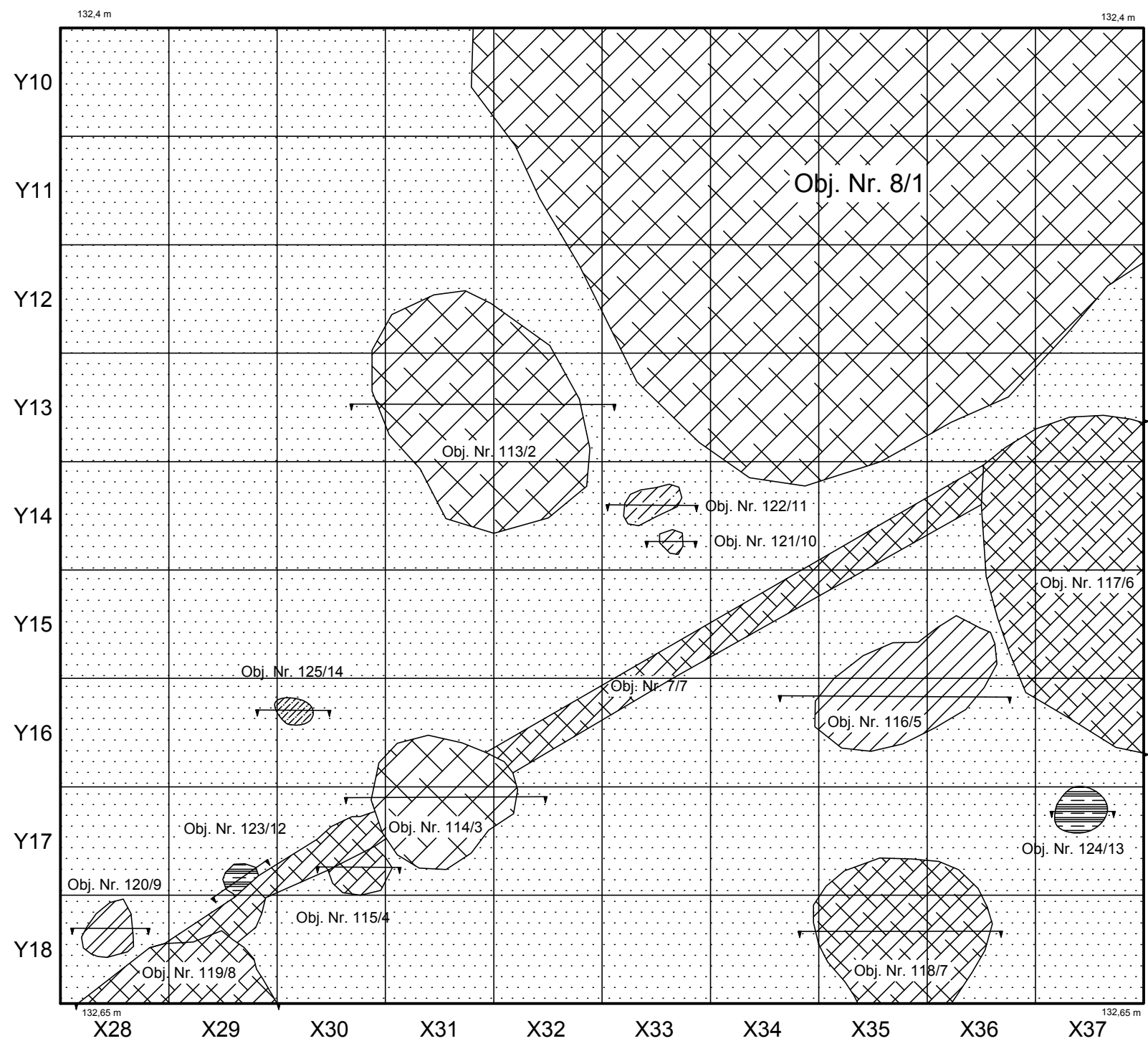

P-21 obj. sit. planas įžemyje (0,8 m gylis)

M1:50

Brėžinys Nr. 86

Obj. Nr. 113/2

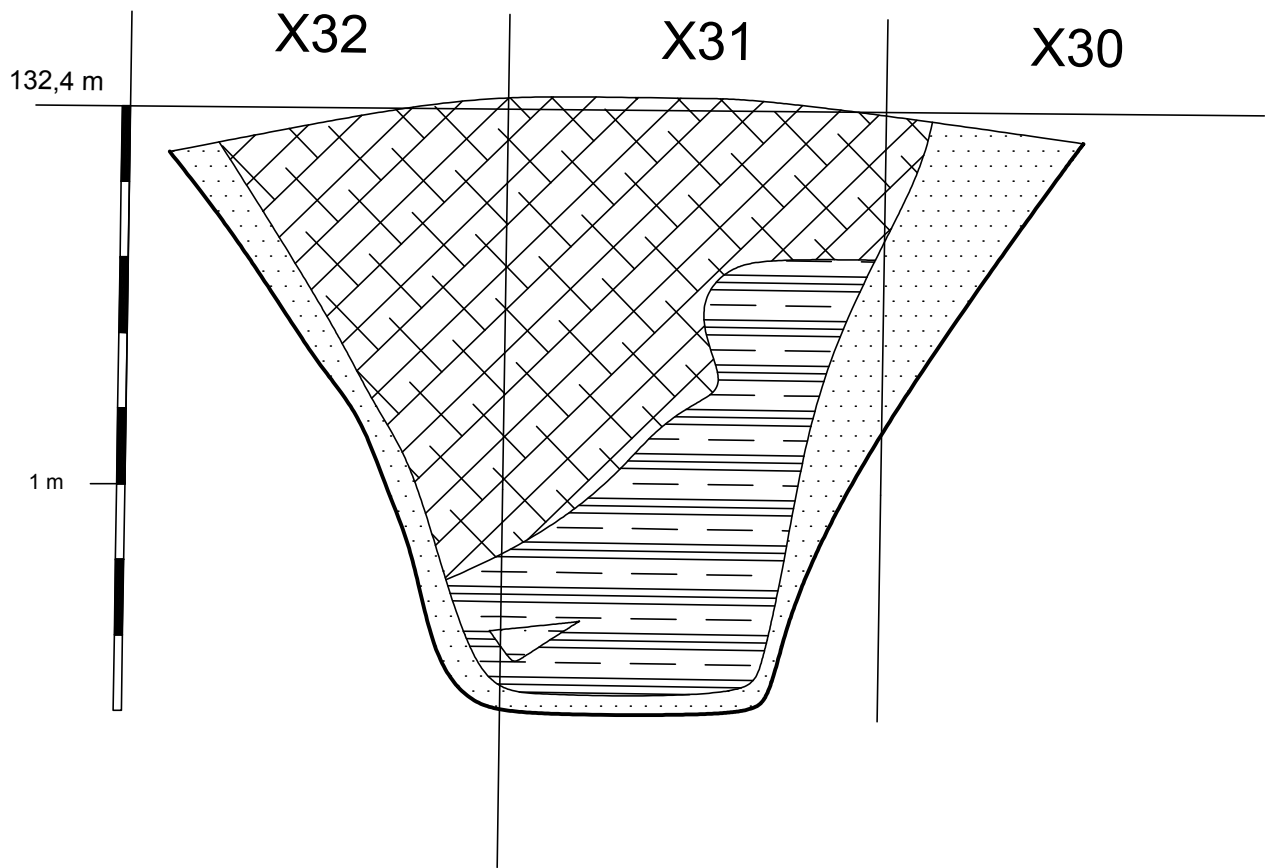

Obj. Nr. 114/3

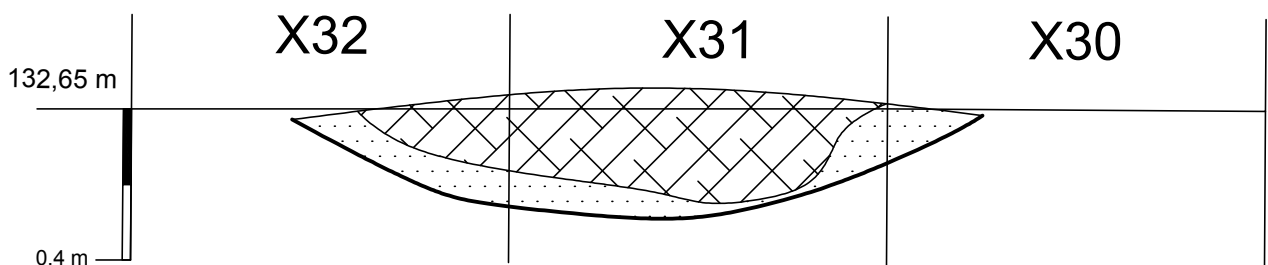

Obj. Nr. 113/2–114/3

M1:20

Brėžinys Nr. 87

Obj. Nr. 115/4

Obj. Nr. 120/9

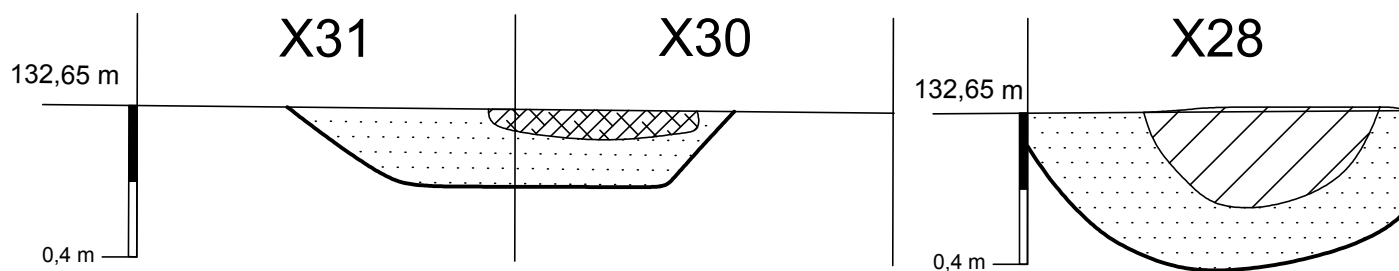

Obj. Nr. 116/5

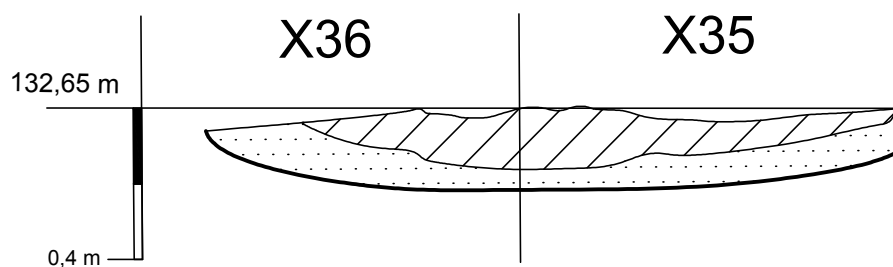

Obj. Nr. 118/7

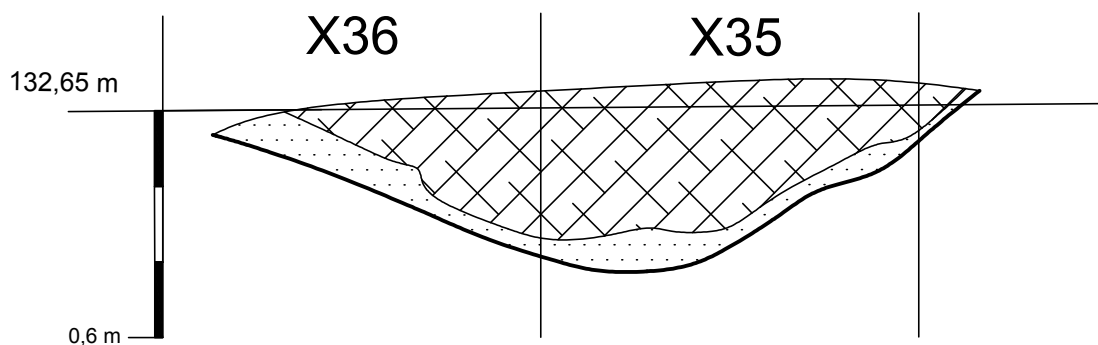

Obj. Nr. 115/4–116/5, 118/7, 120/9

M1:20

Brėžinys Nr. 88

Obj. Nr. 121/10

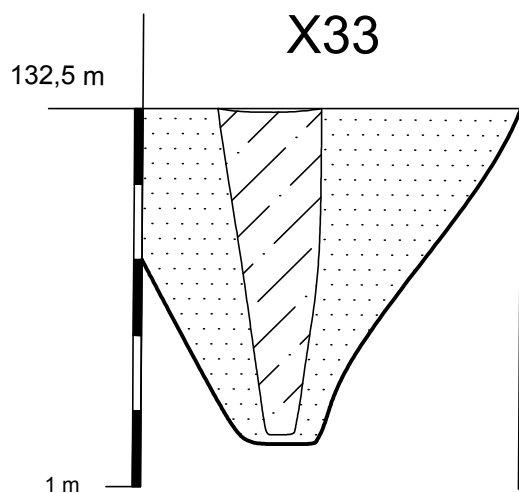

Obj. Nr. 122/11

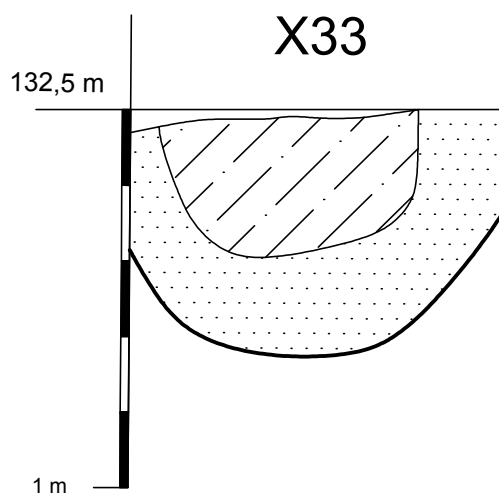

Obj. Nr. 123/12

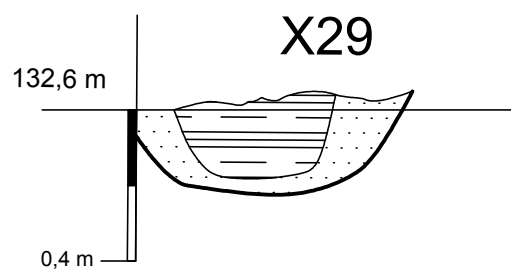

Obj. Nr. 124/13

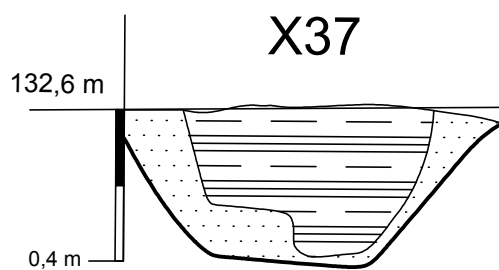

Obj. Nr. 121/10–124/13

M1:20

Brėžinys Nr. 89

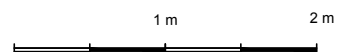
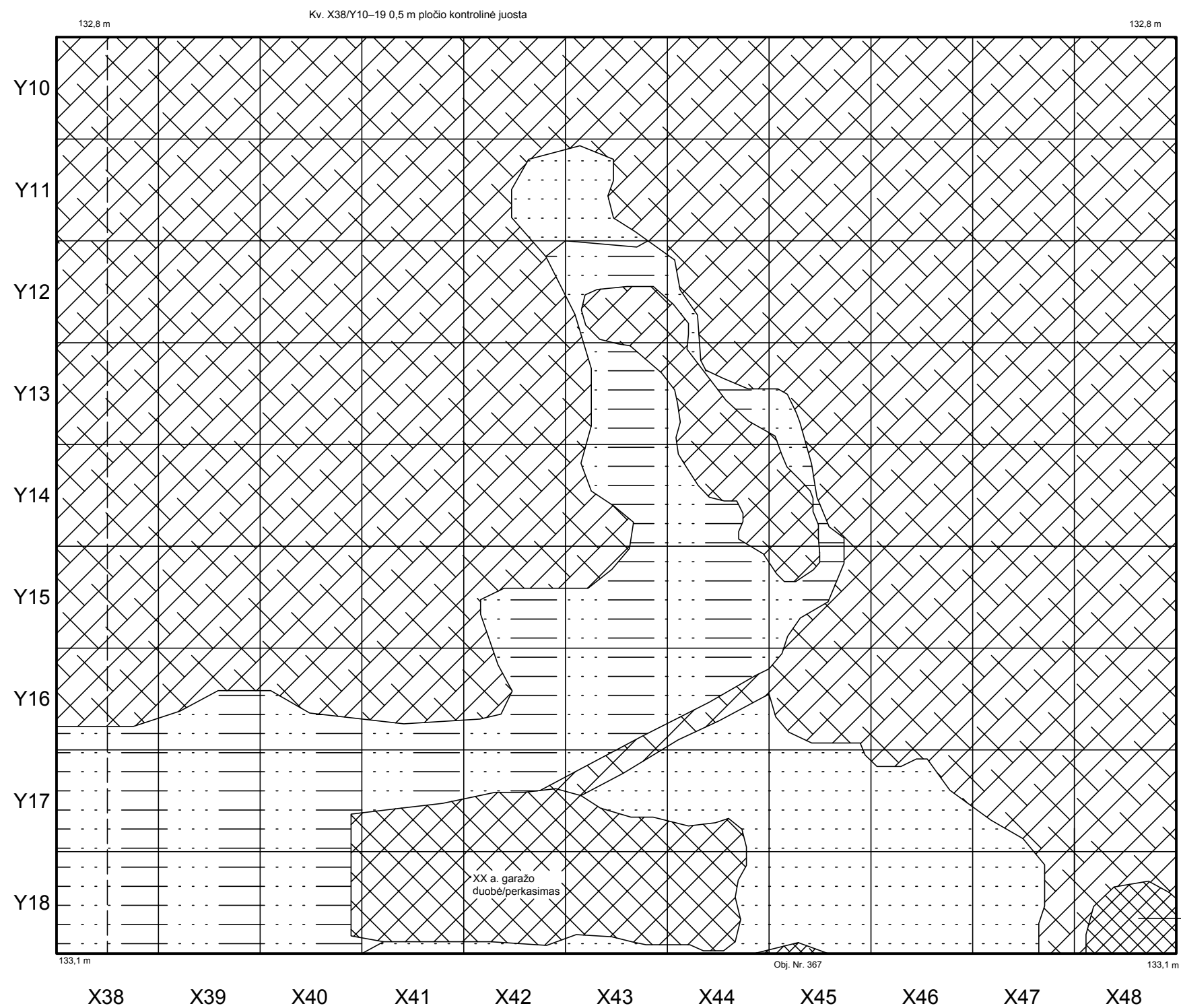

P-22 sit. planas (0,2 m gylis)
M1:50
Brėžinys Nr. 90

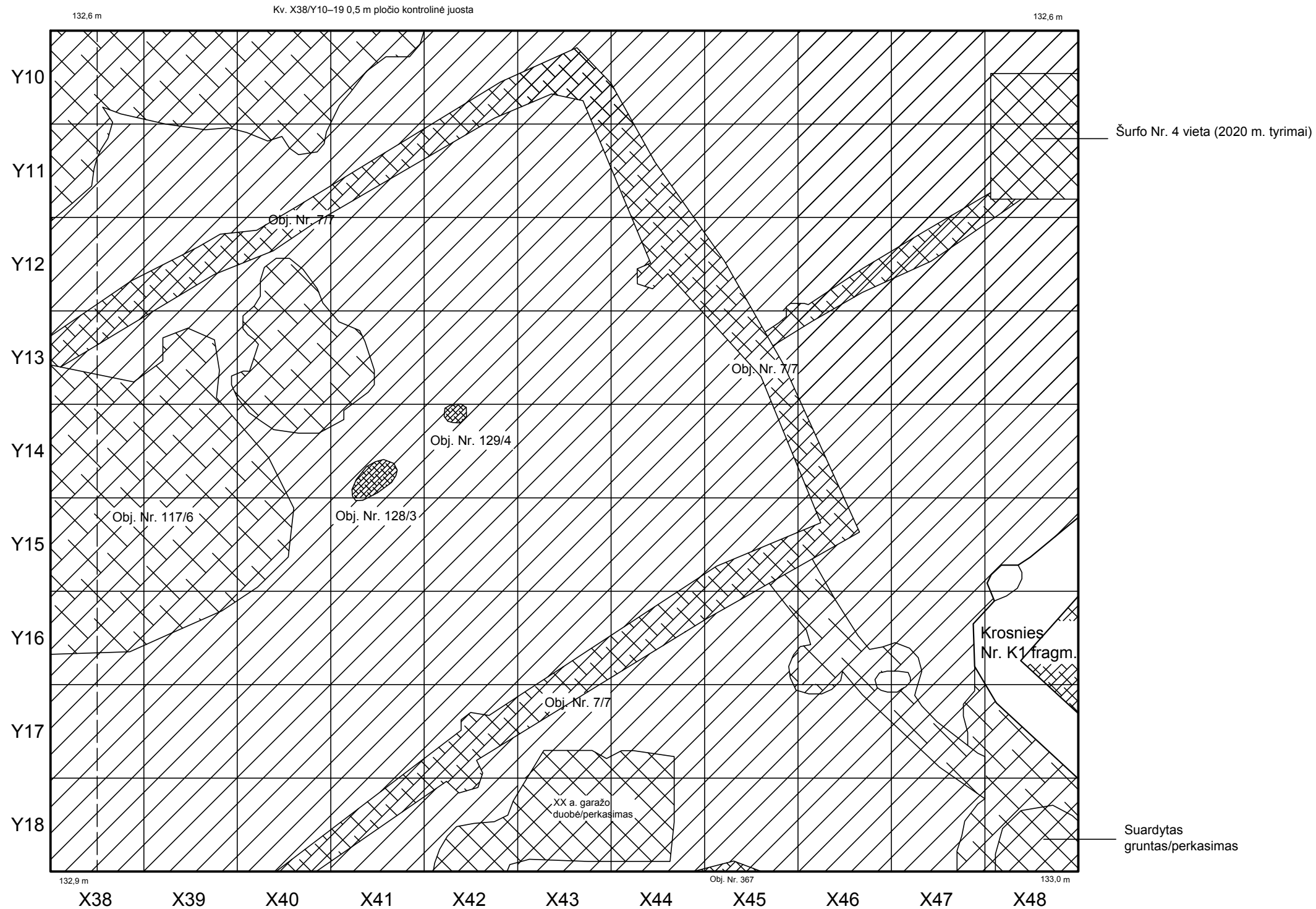

P–22 t. p. ž. sluoksnio (XV a.) sit. planas (0,5–0,6 m gylis)

M1:50

Brėžinys Nr. 91

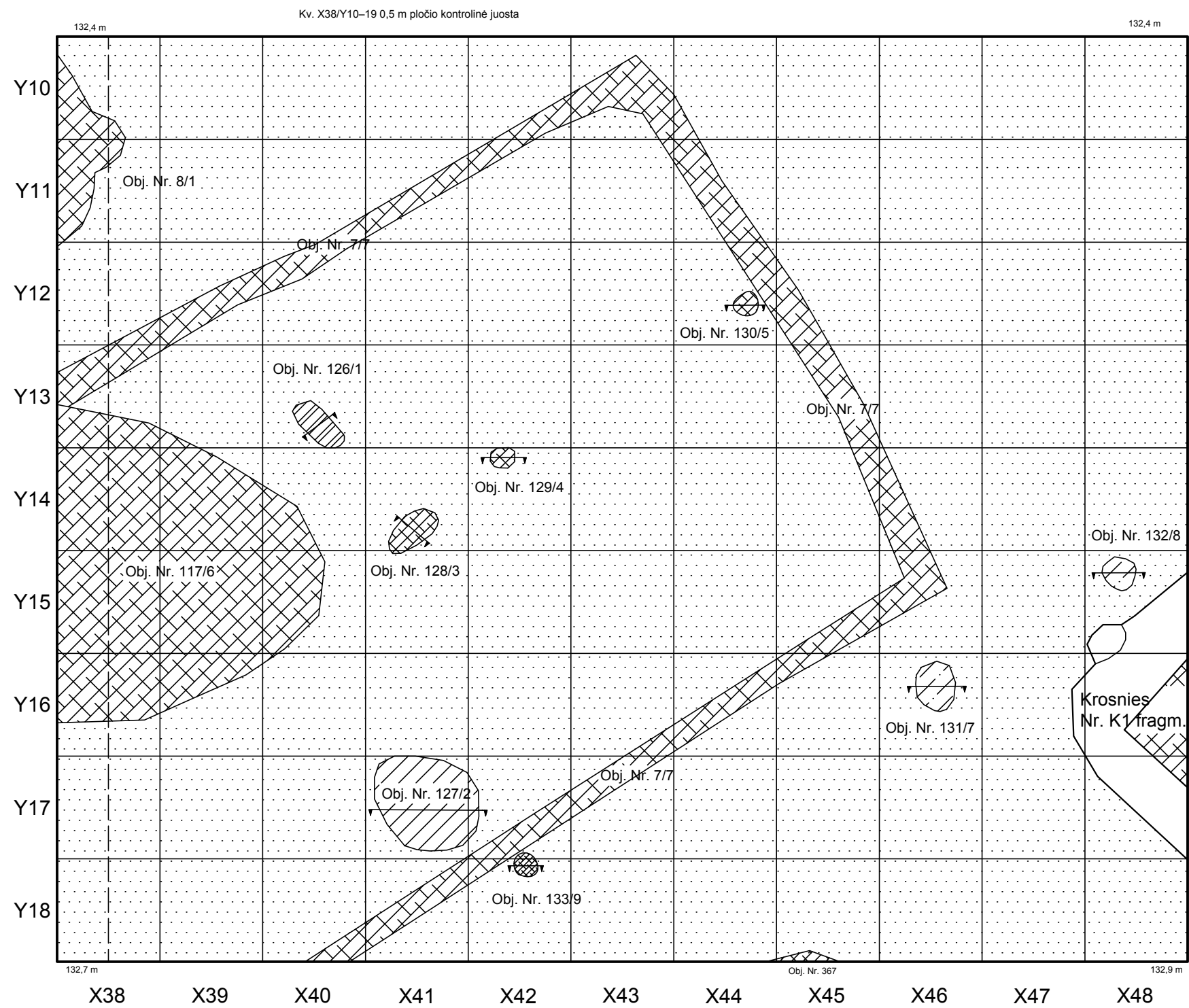

P-22 obj. sit. planas įžemyje (0,5–0,6 m gylis)

M1:50

Brėžinys Nr. 92

Obj. Nr. 126/1

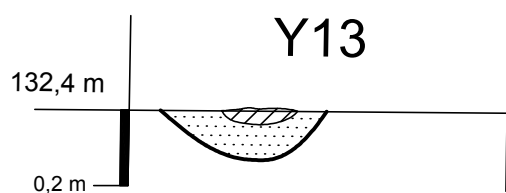

Obj. Nr. 127/2

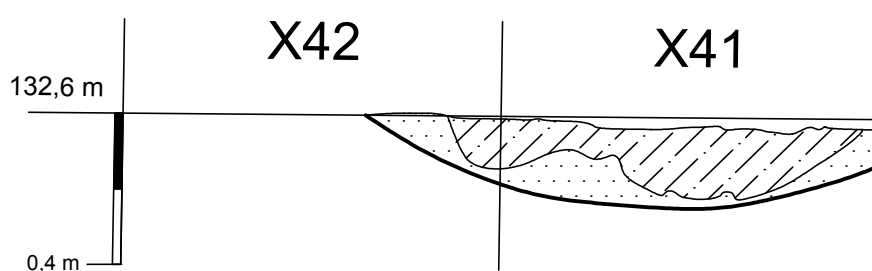

Obj. Nr. 128/3

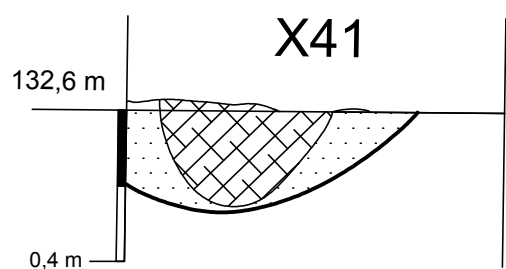

Obj. Nr. 129/4

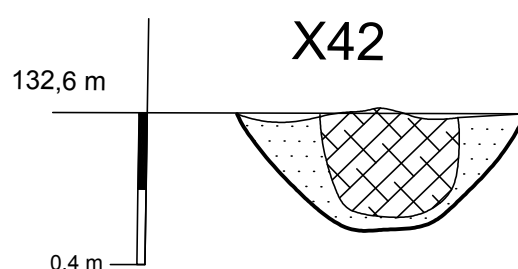

Obj. Nr. 130/5

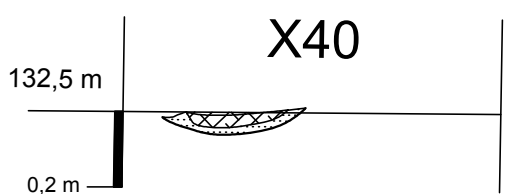

Obj. Nr. 131/7

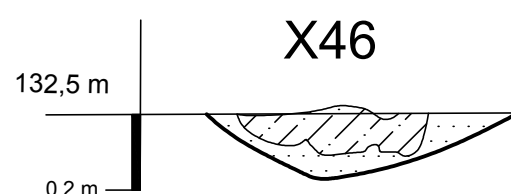

Obj. Nr. 133/9

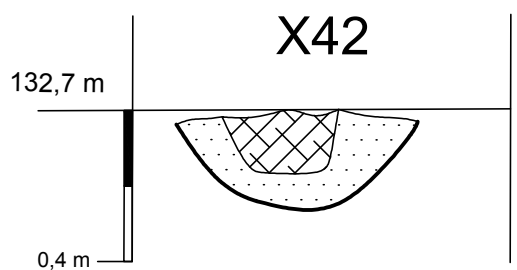

Obj. Nr. 132/8

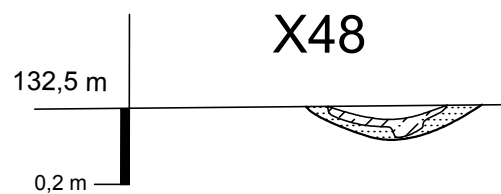

Obj. Nr. 126/1–130/5, 131/7–133/9

M1:20

Brėžinys Nr. 93



P-21 R sienos pjūvis

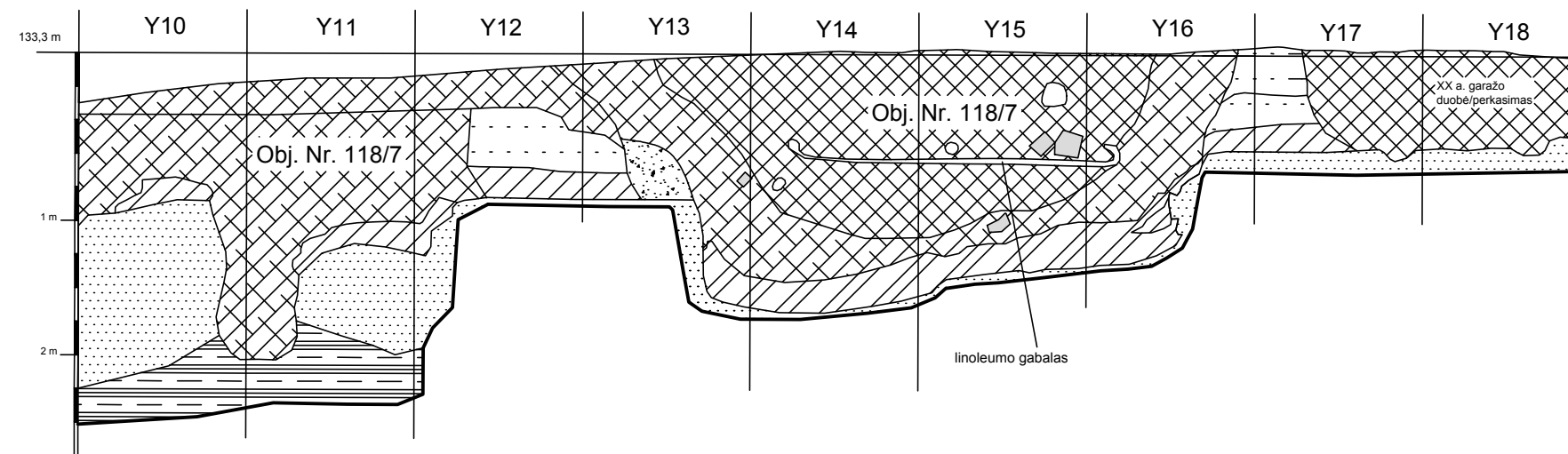

P-21 P sienos pjūvis

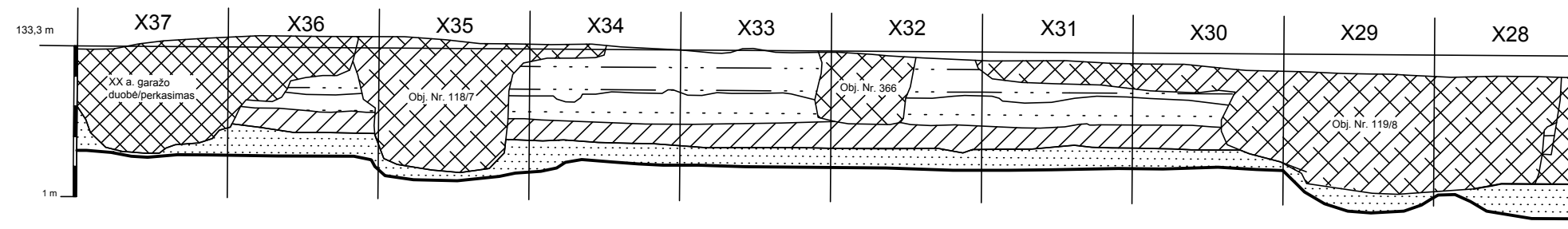

P-22 P sienos pjūvis

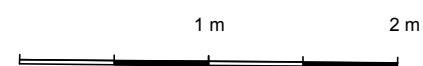
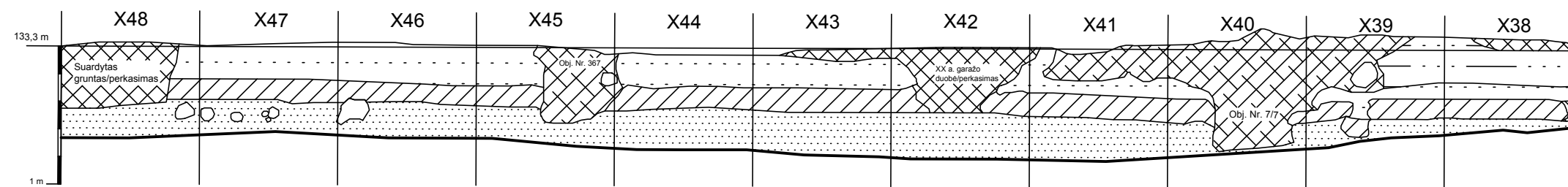

P-21 R, P sienų pjūviai; P-22 P sienos pjūvis
M1:40
Brėžinys Nr. 94

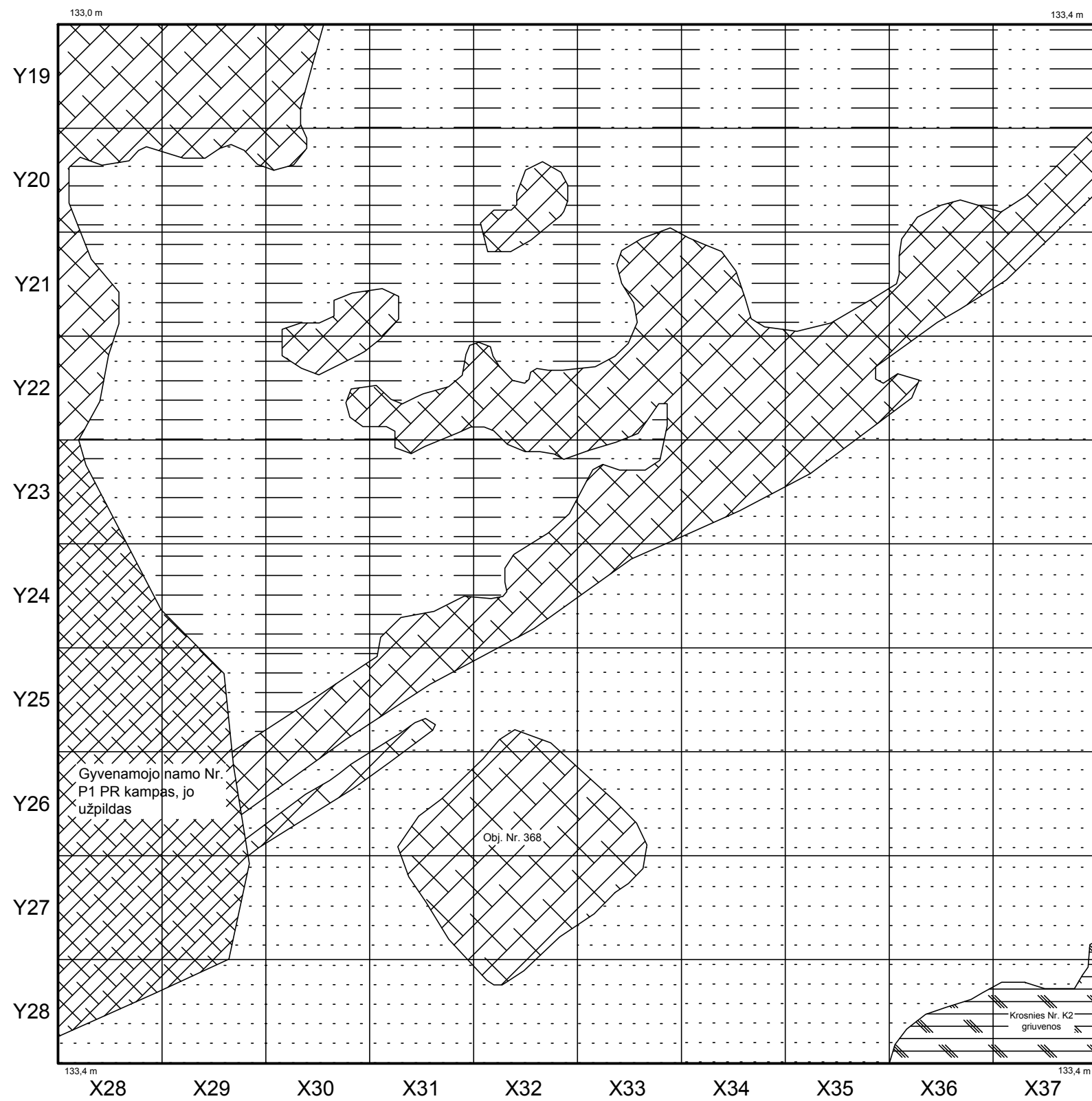

P-23 sit. planas (0,2 m gylis)
M1:50
Brėžinys Nr. 95

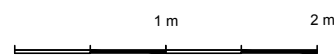
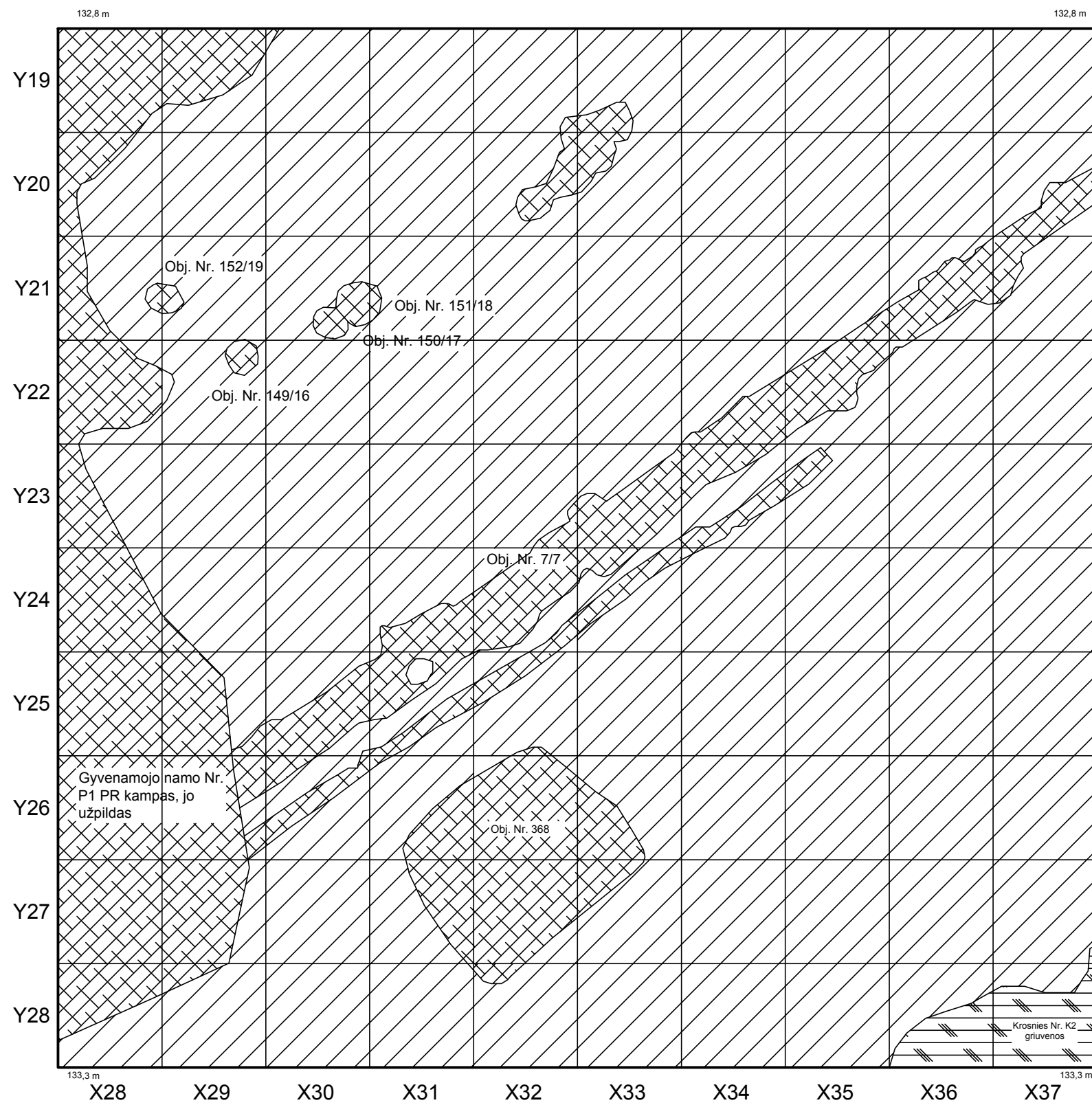

P-23 t. p. ž. sluoksniu (XV a.) sit. planas (0,4 m gylis)

M1:50

Brėžinys Nr. 96

Obj. Nr. 135/2

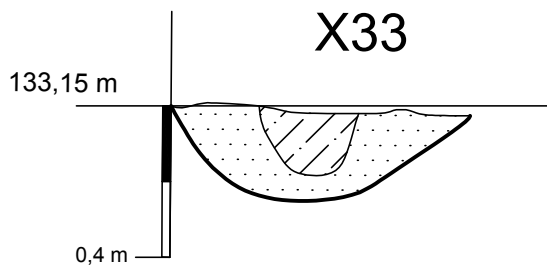

Obj. Nr. 137/4

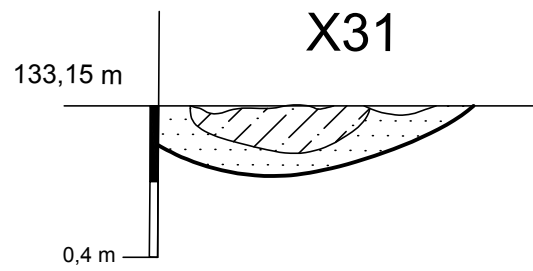

Obj. Nr. 136/3

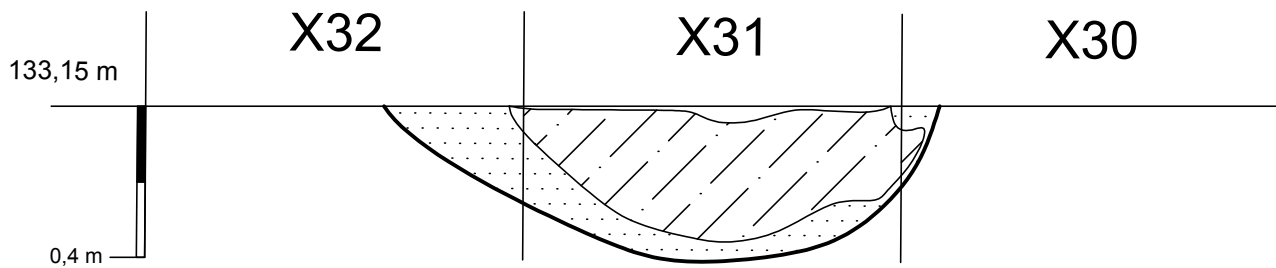

Obj. Nr. 138/5

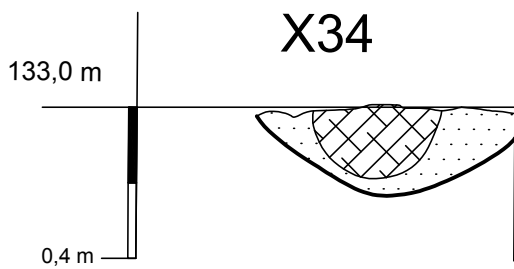

Obj. Nr. 139/6

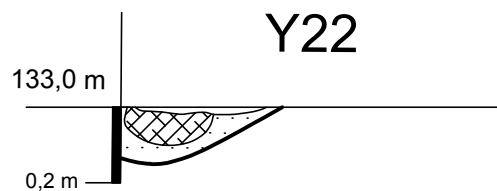

Obj. Nr. 135/2–139/6

M1:20

Brėžinys Nr. 97.1

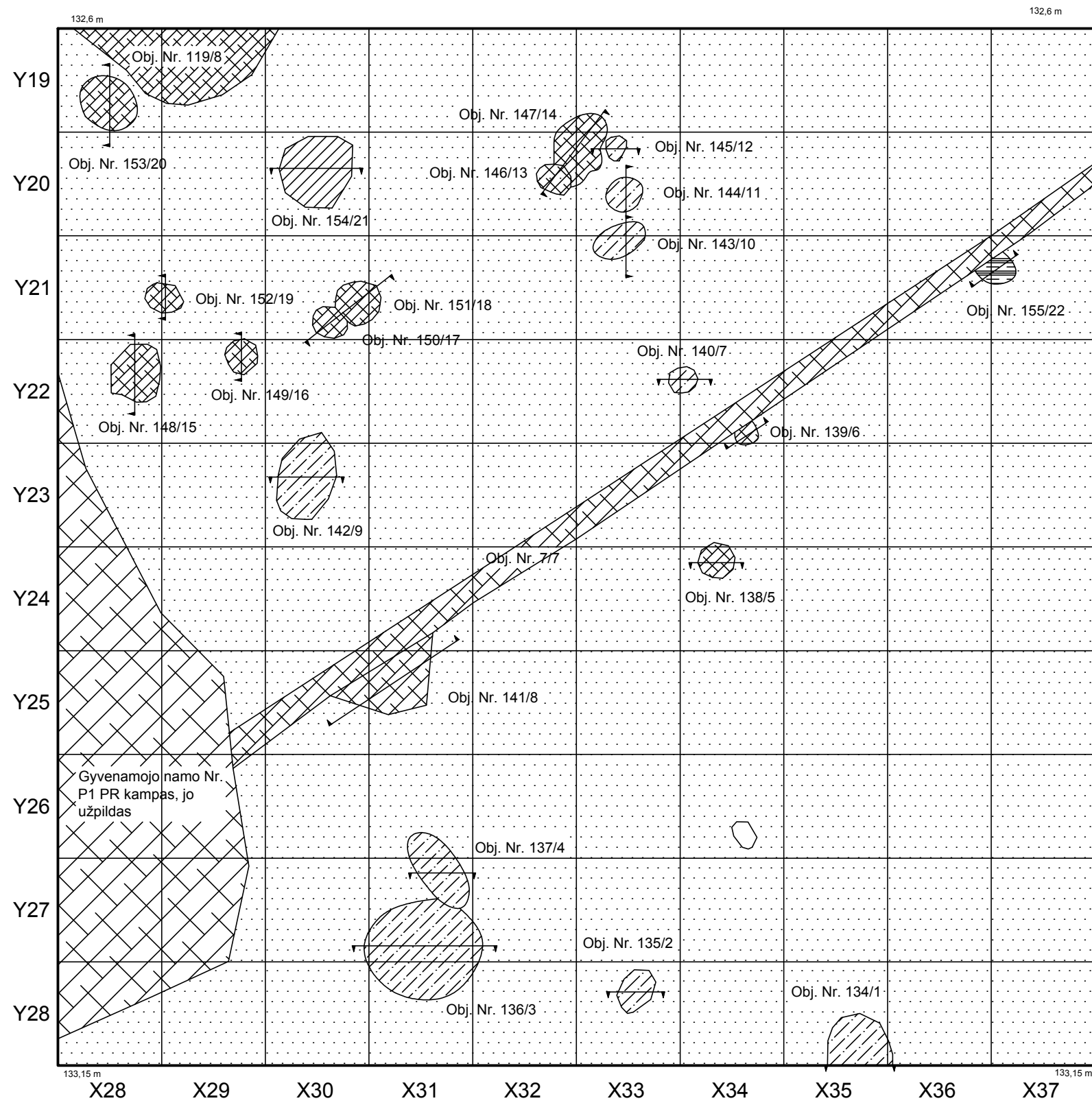

P-23 obj. sit. planas įžemyje (0,5–0,6 m gylis)

M1:50

Brėžinys Nr. 97

Obj. Nr. 140/7

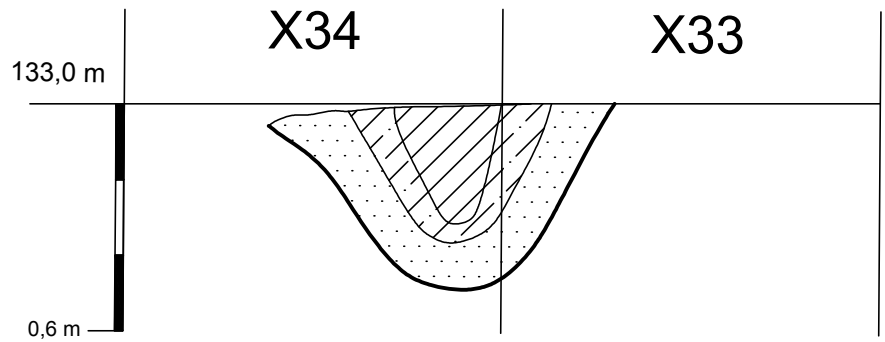

Obj. Nr. 141/8

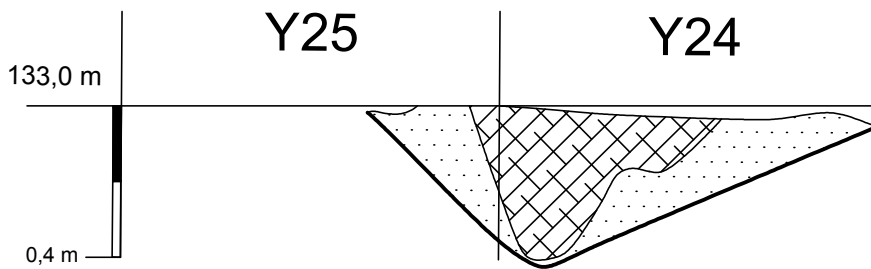

Obj. Nr. 142/9

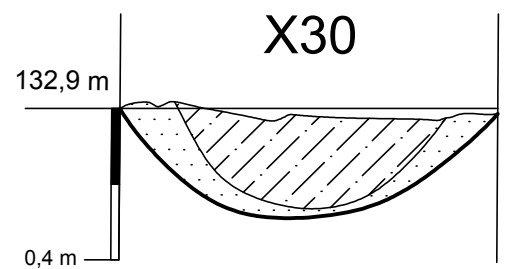

Obj. Nr. 143/10

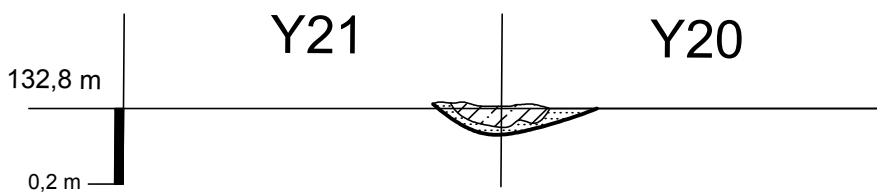

Obj. Nr. 144/11

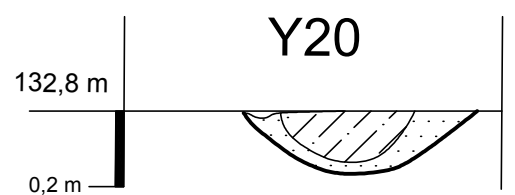

Obj. Nr. 145/12

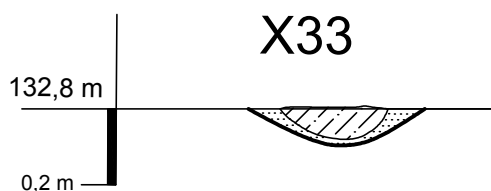

Obj. Nr. 140/7–145/12

M1:20

Brėžinys Nr. 98

Obj. Nr. 147/14

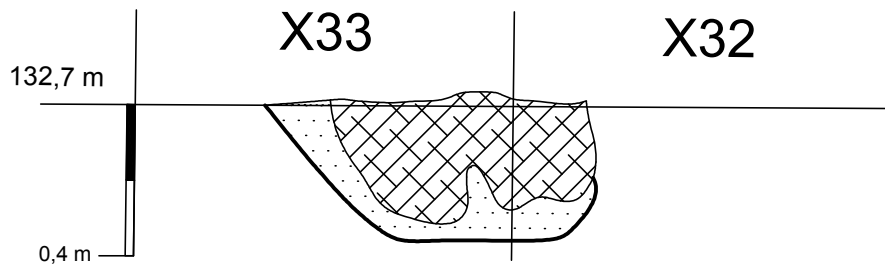

Obj. Nr. 146/13

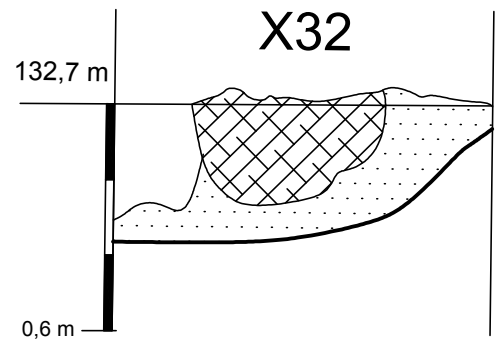

Obj. Nr. 148/15

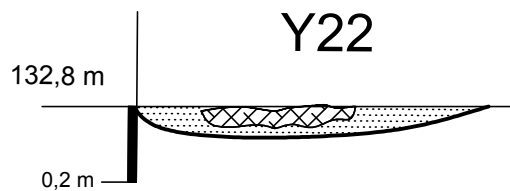

Obj. Nr. 149/16

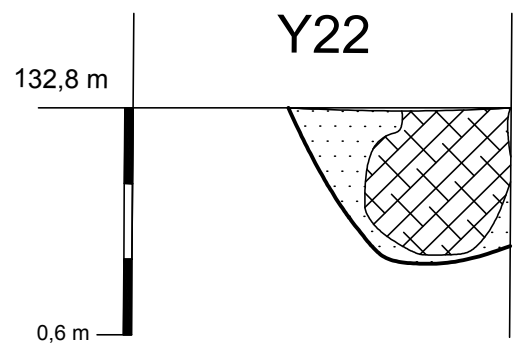

Obj. Nr. 151/18, Obj. Nr. 150/17

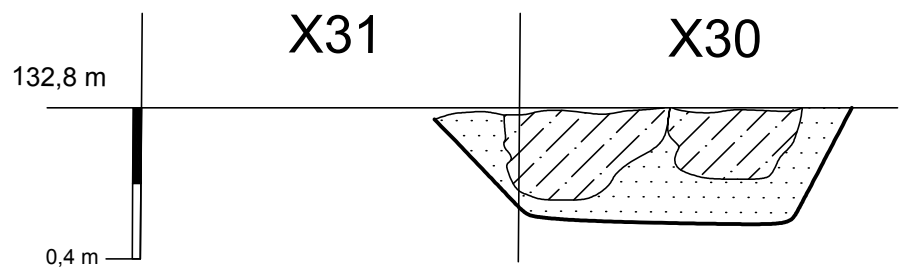

Obj. Nr. 146/13–151/18

M1:20

Brėžinys Nr. 99

Obj. Nr. 152/19

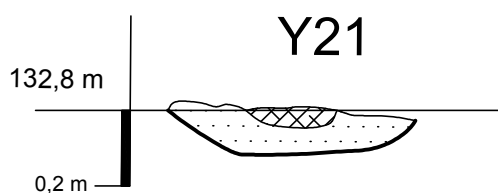

Obj. Nr. 154/21

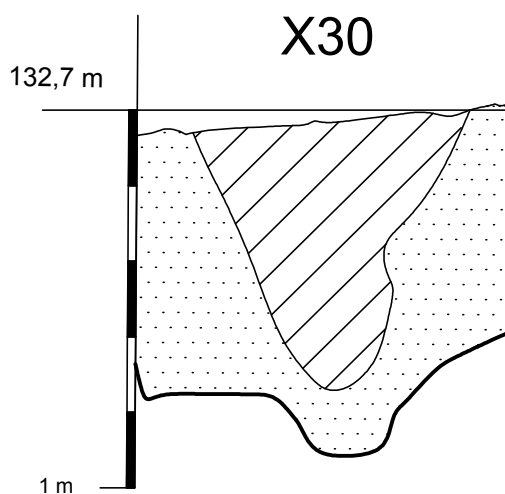

Obj. Nr. 155/22

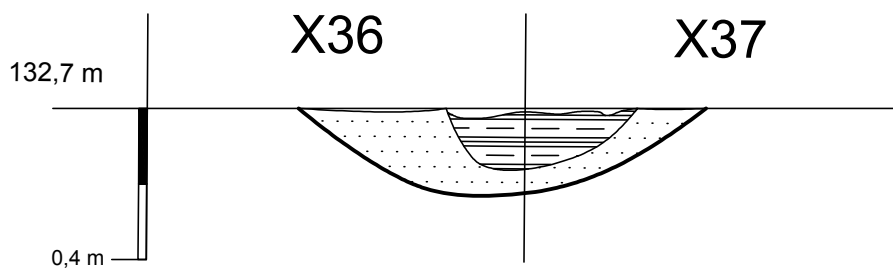

Obj. Nr. 152/19, 154/21–155/22

M1:20

Brėžinys Nr. 100



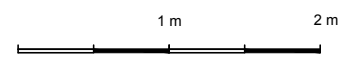
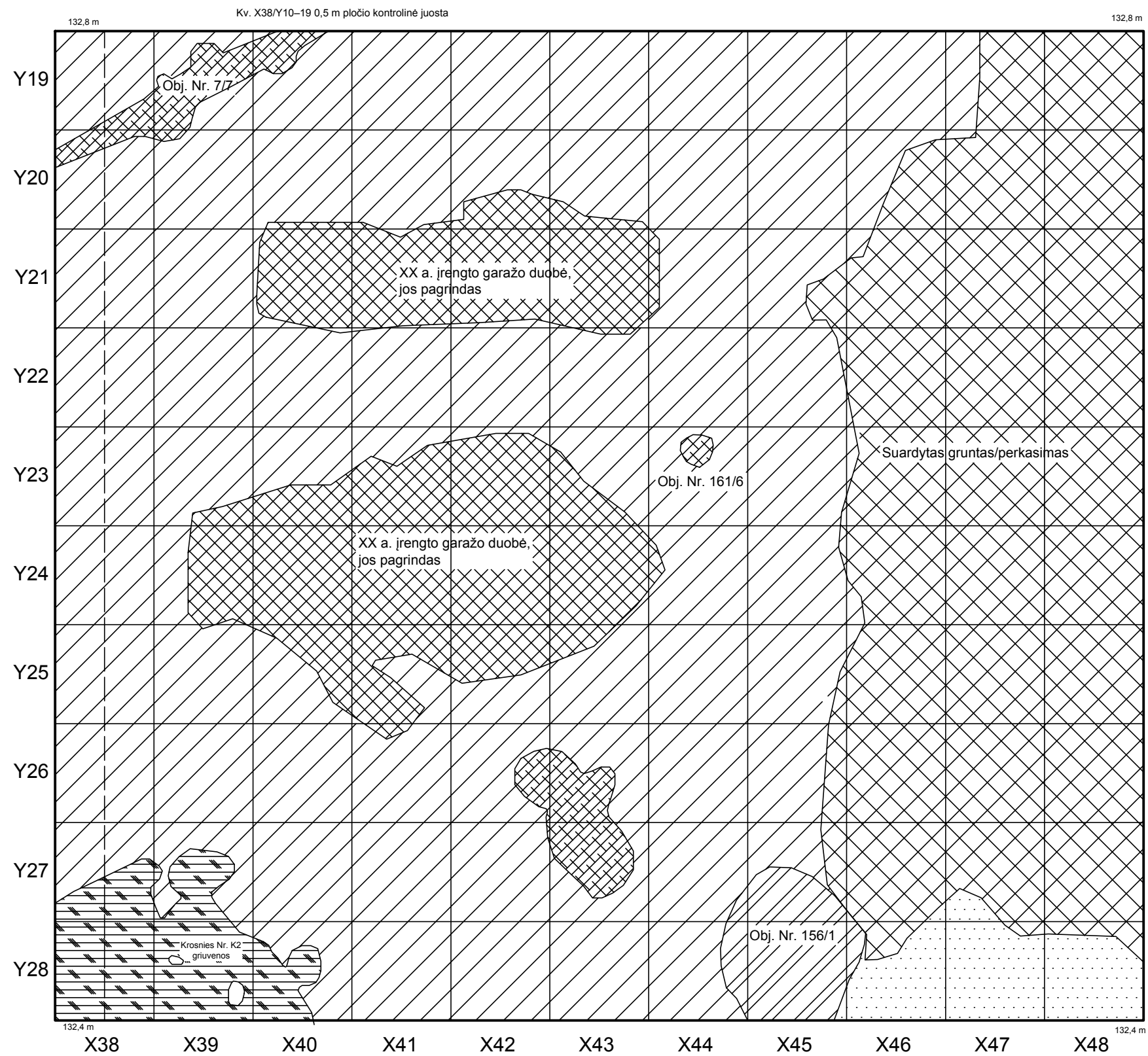

P-24 t. p. ž. sluoksnio (XV a.) sit. planas (0,1–0,3 m gylis)
M1:50
Brėžinys Nr. 101

Kv. X38/Y10–19 0,5 m pločio kontrolinė juosta

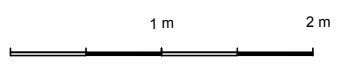
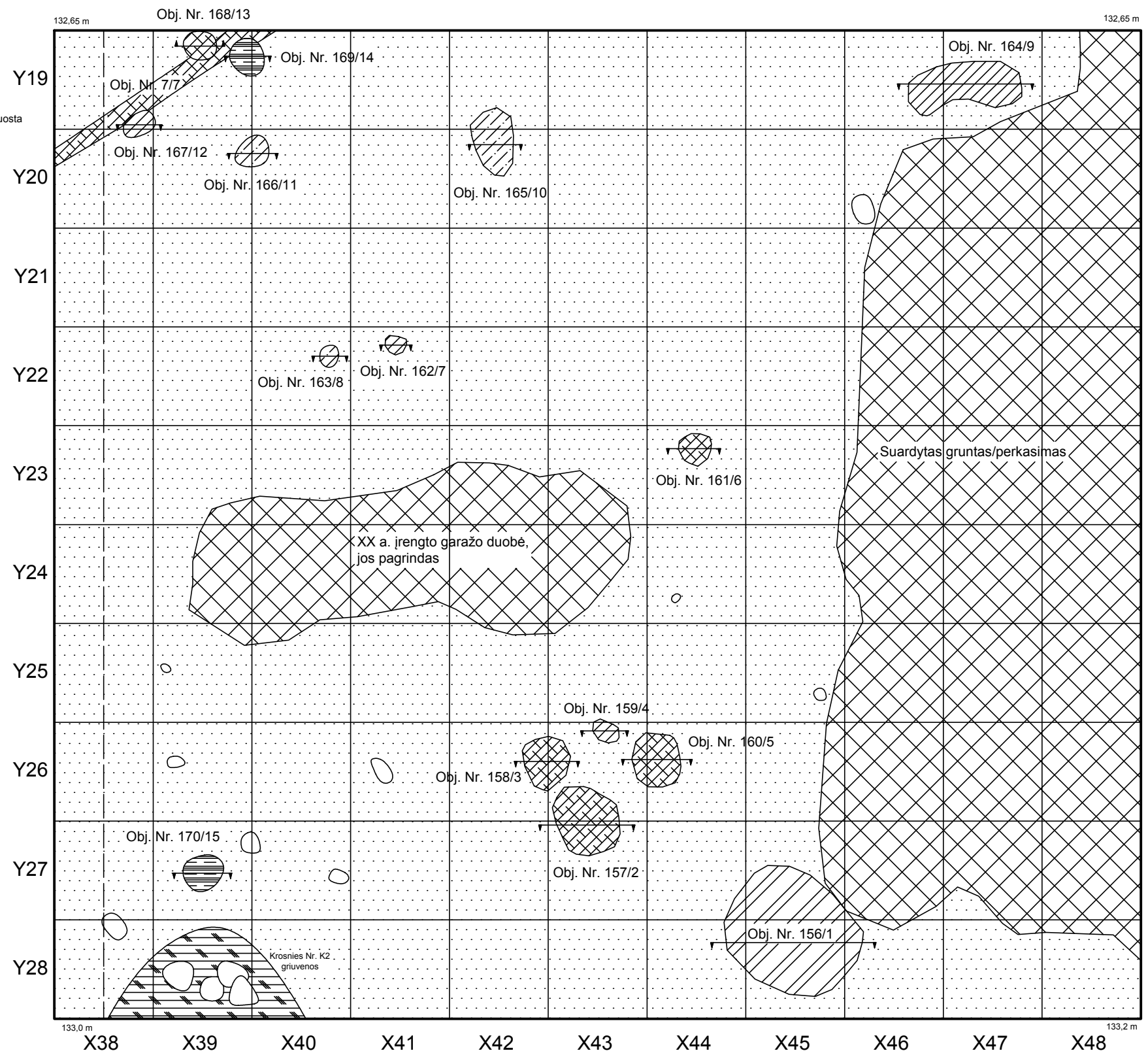

P-24 obj. sit. planas įžemyje (0,4–0,5 m gylis)
M1:50
Brėžinys Nr. 102

Obj. Nr. 156/1

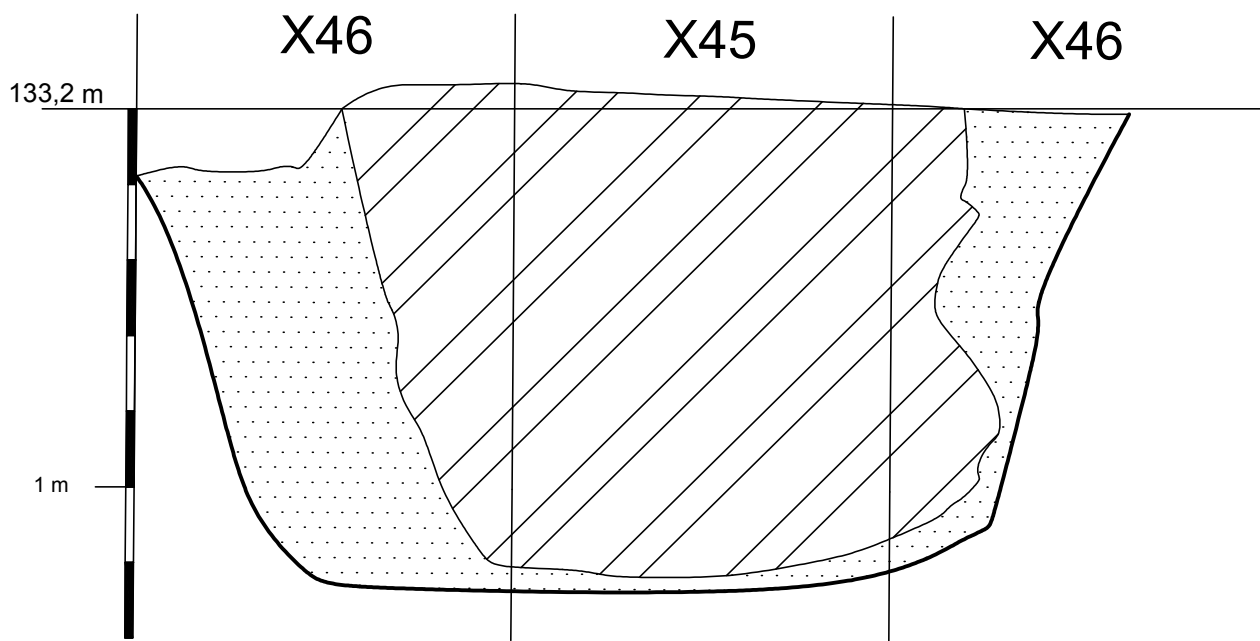

Obj. Nr. 157/2

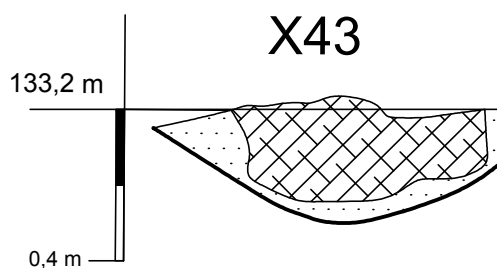

Obj. Nr. 158/3

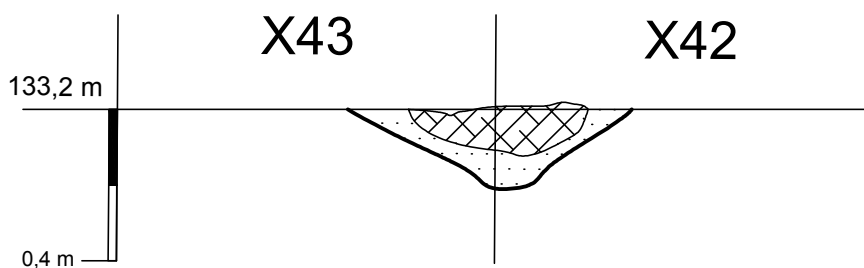

Obj. Nr. 159/4

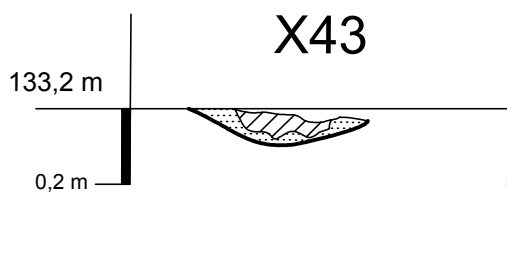

Obj. Nr. 160/5

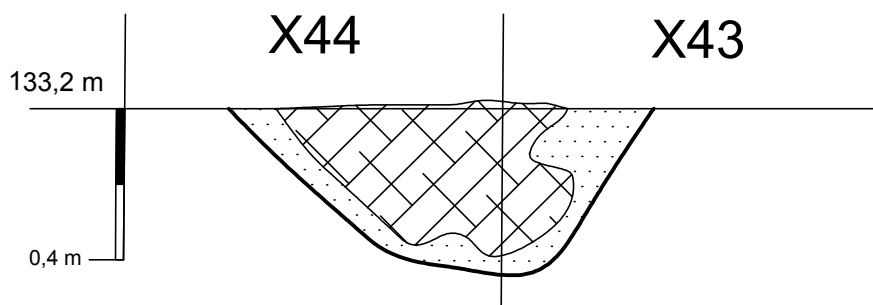

Obj. Nr. 156/1–160/5

M1:20

Brėžinys Nr. 103



Obj. Nr. 161/6

Obj. Nr. 162/7

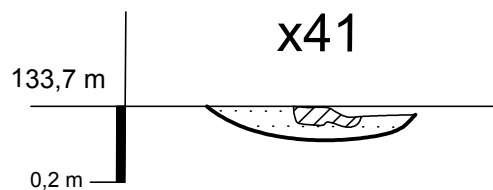
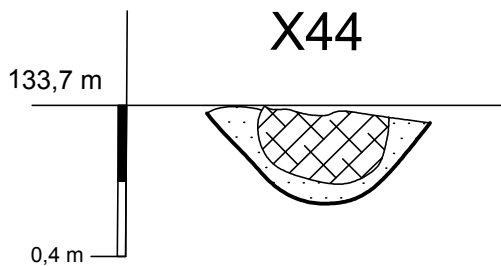

Obj. Nr. 163/8

Obj. Nr. 164/9

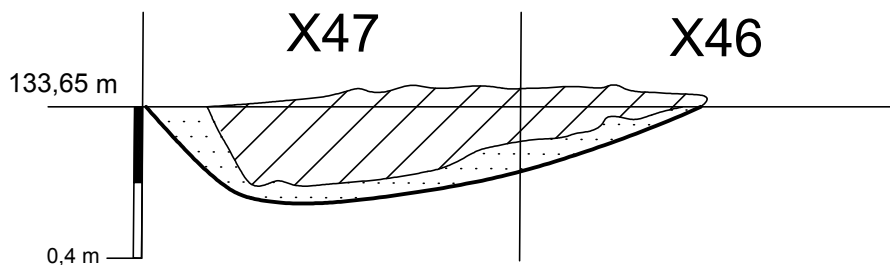
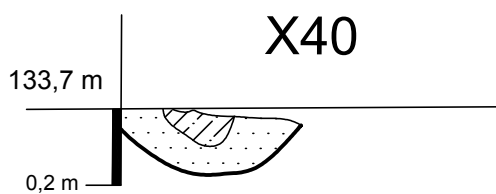

Obj. Nr. 166/11

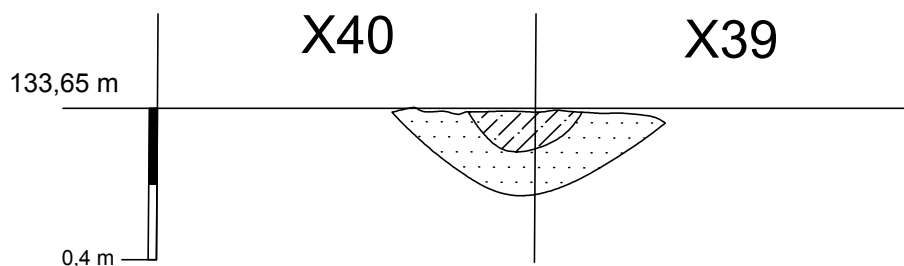

Obj. Nr. 161/6–164/9, 166/11

M1:20

Brėžinys Nr. 104

Obj. Nr. 167/12

Obj. Nr. 168/13

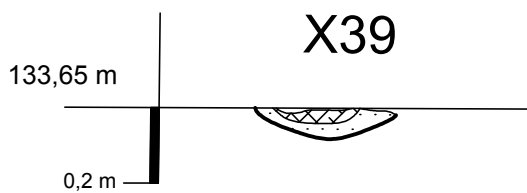
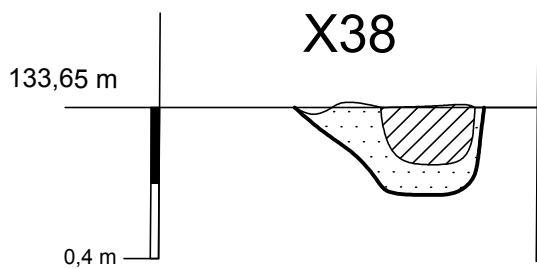

Obj. Nr. 169/14

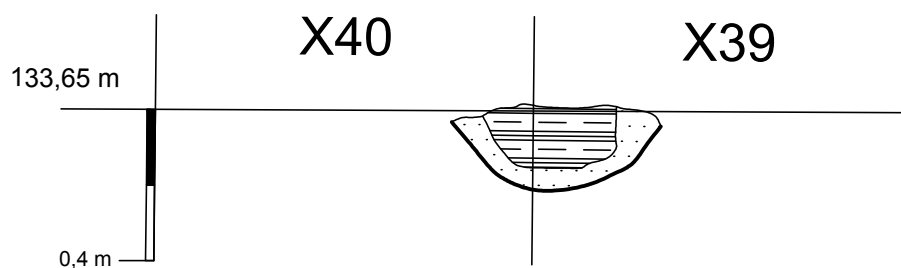

Obj. Nr. 170/15

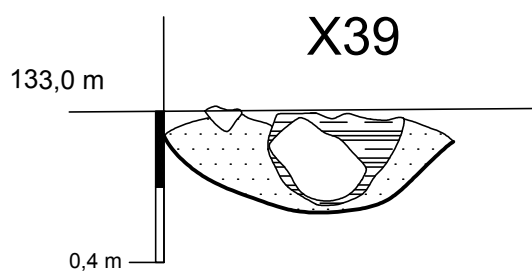

Obj. Nr. 167/12–170/15

M1:20

Brėžinys Nr. 105

P-23 R sienos pjūvis

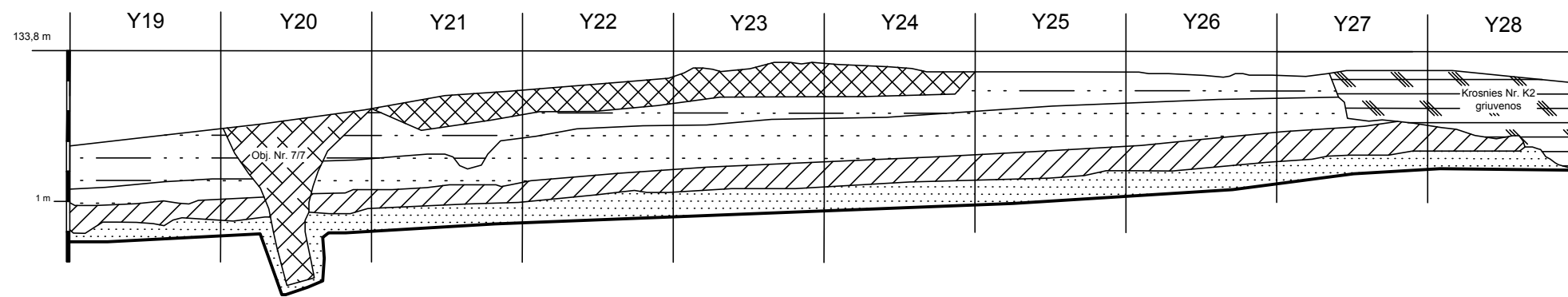

P-23 P sienos pjūvis

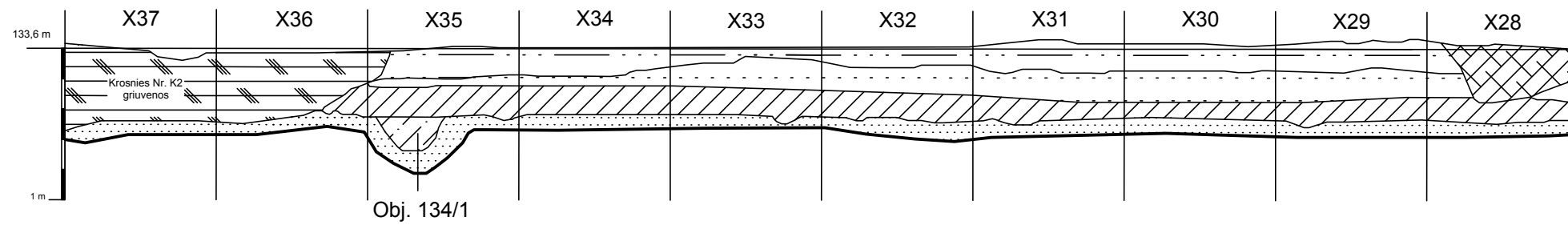

P-24 P sienos pjūvis (Kv. X44-X38)

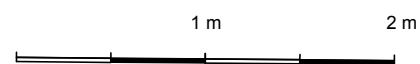
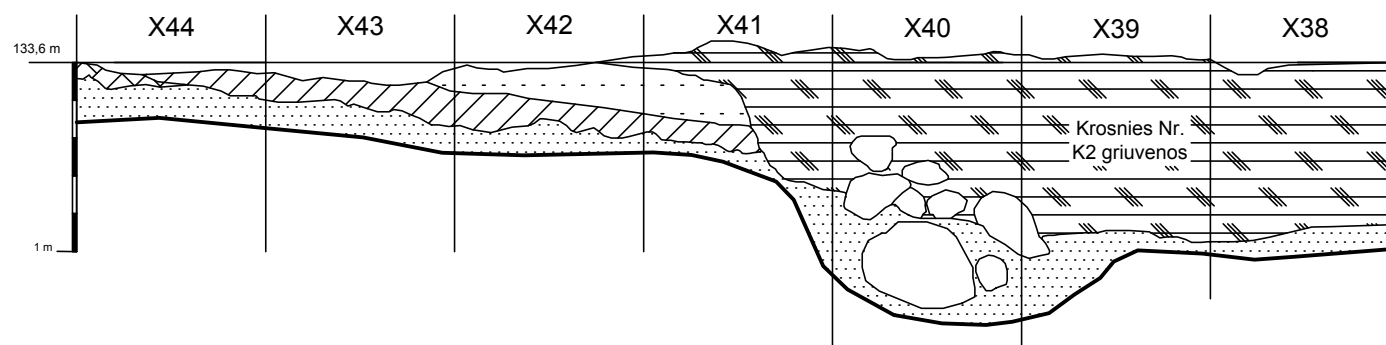

P-23 R, P sienų pjūviai; P-24 P sienos pjūvis (Kv. X44-X38)

M1:40

Brėžinys Nr. 106

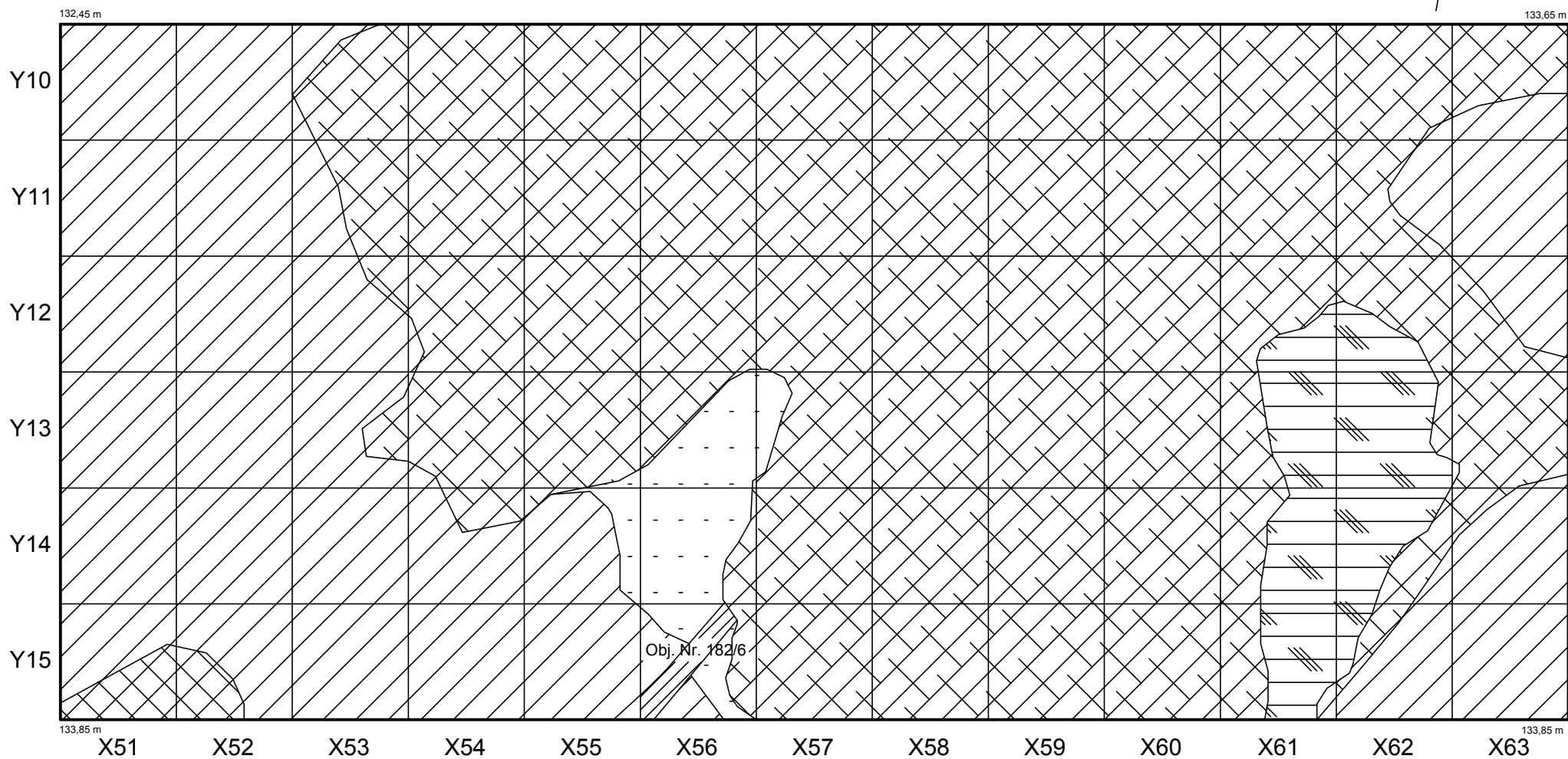

P-25 t. p. ž. sluoksniu (XV a.) sit. planas (0,4–0,8 m gylis)

M1:50

Brėžinys Nr. 107

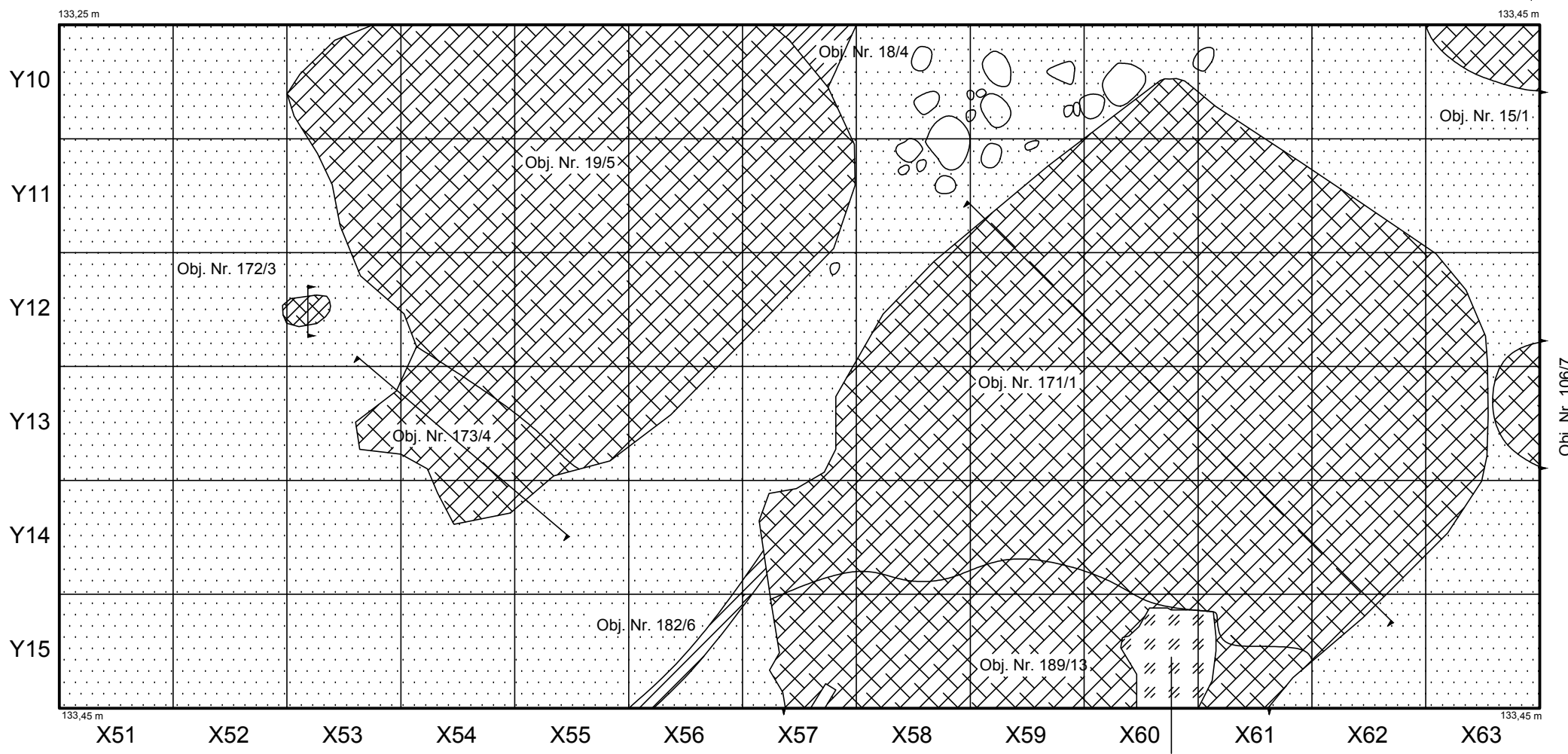

Betono luitas

P-25 obj. sit. planas įžemyje (0,6–1,2 m gylis)

M1:50

Brėžinys Nr. 108



P-26 t. p. ž. sluoksniu (XV a.) sit. planas (0,4–0,6 m gylis)

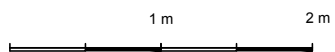
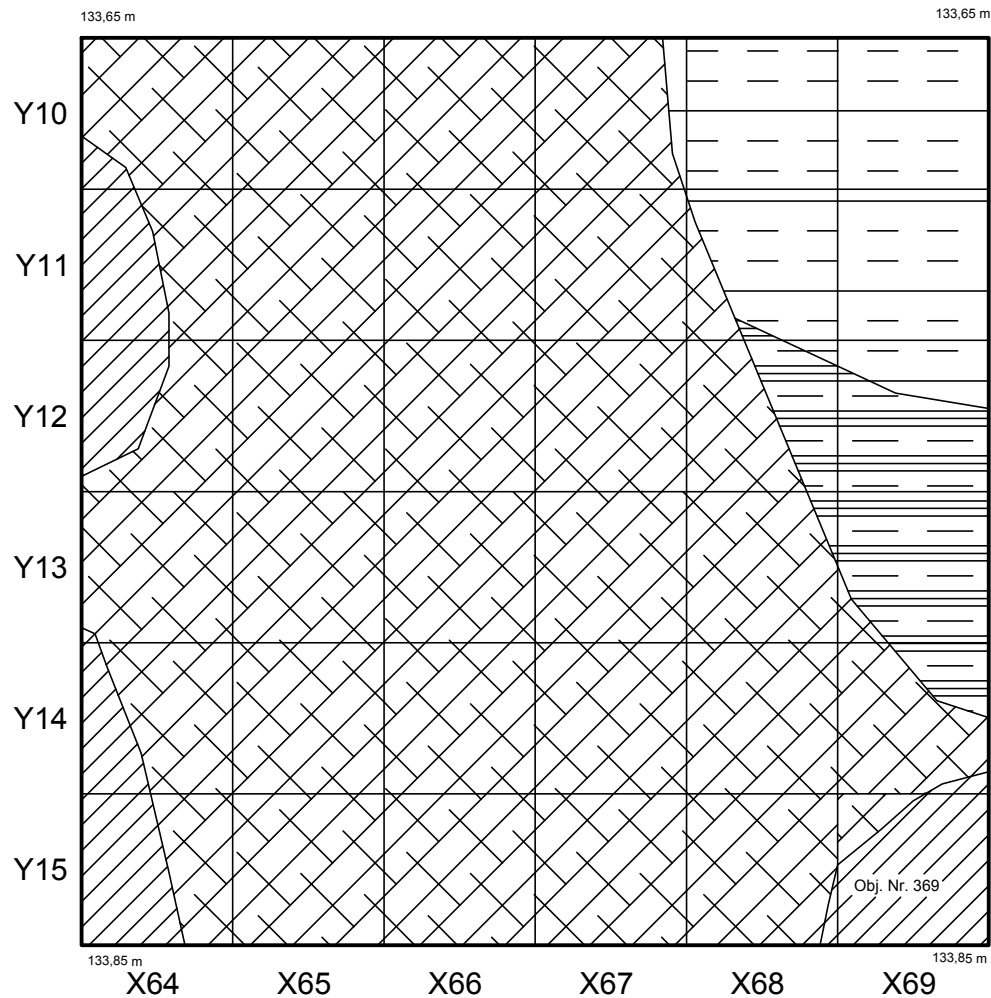

P-26 obj. sit. planas įžemyje (1 m gylis)

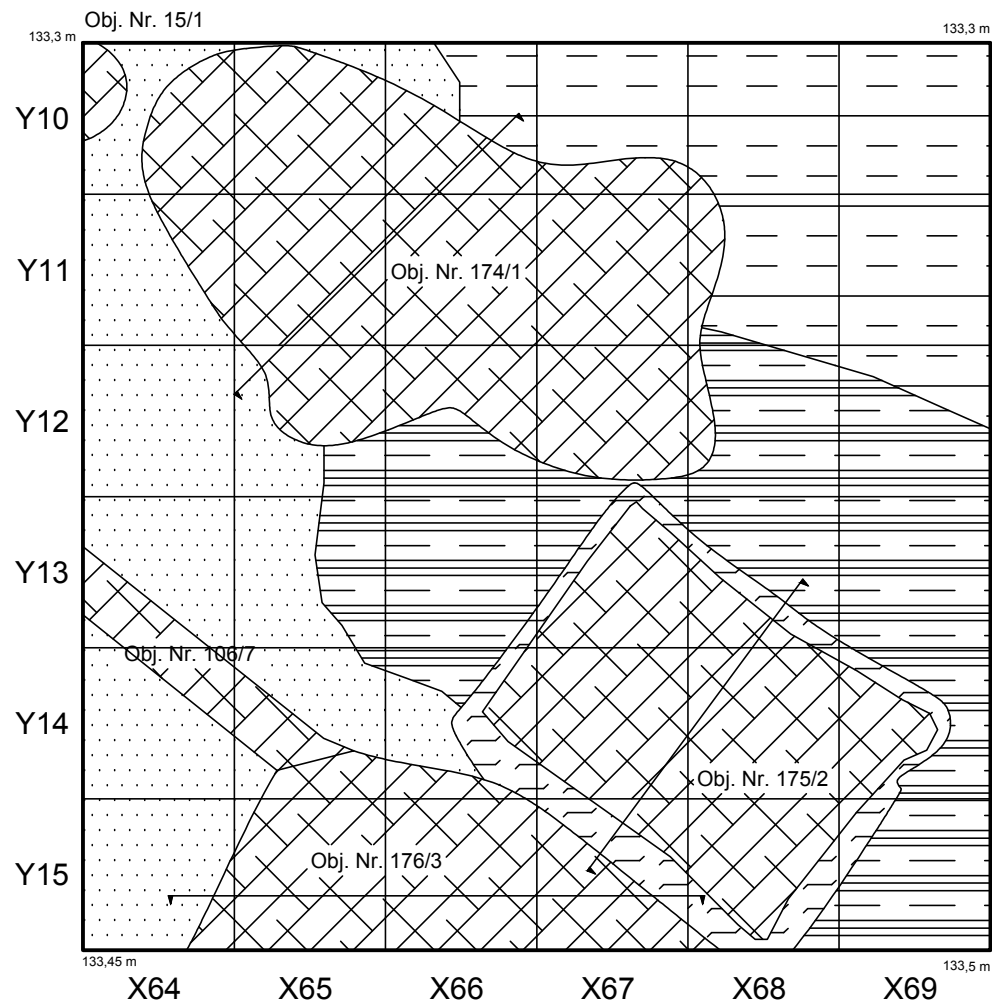

P-26 t. p. ž. sluoksniu (XV a.) sit. planas (0,8–0,9 m gylis);  
P-26 obj. sit. planas įžemyje (1 m gylis)

M1:50

Brėžinys Nr. 109

Obj. Nr. 171/1

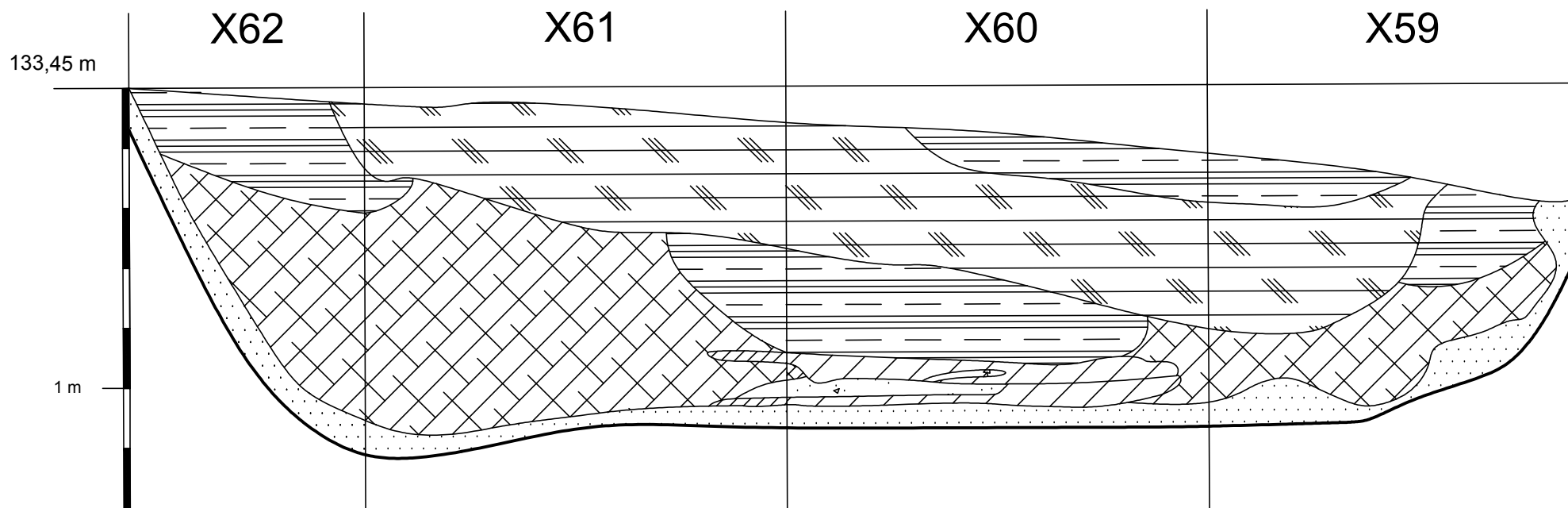

Obj. Nr. 172/3

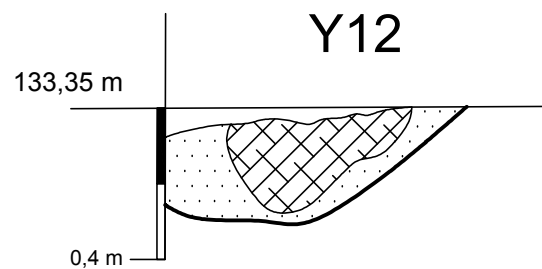

Obj. Nr. 171/1–172/3

M1:20

Brėžinys Nr. 110

Obj. Nr. 173/4

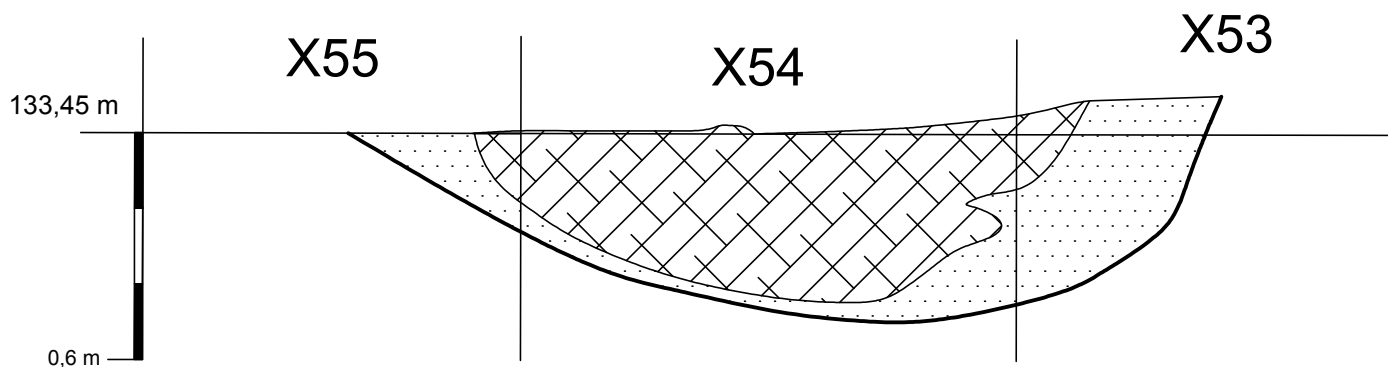

Obj. Nr. 174/1

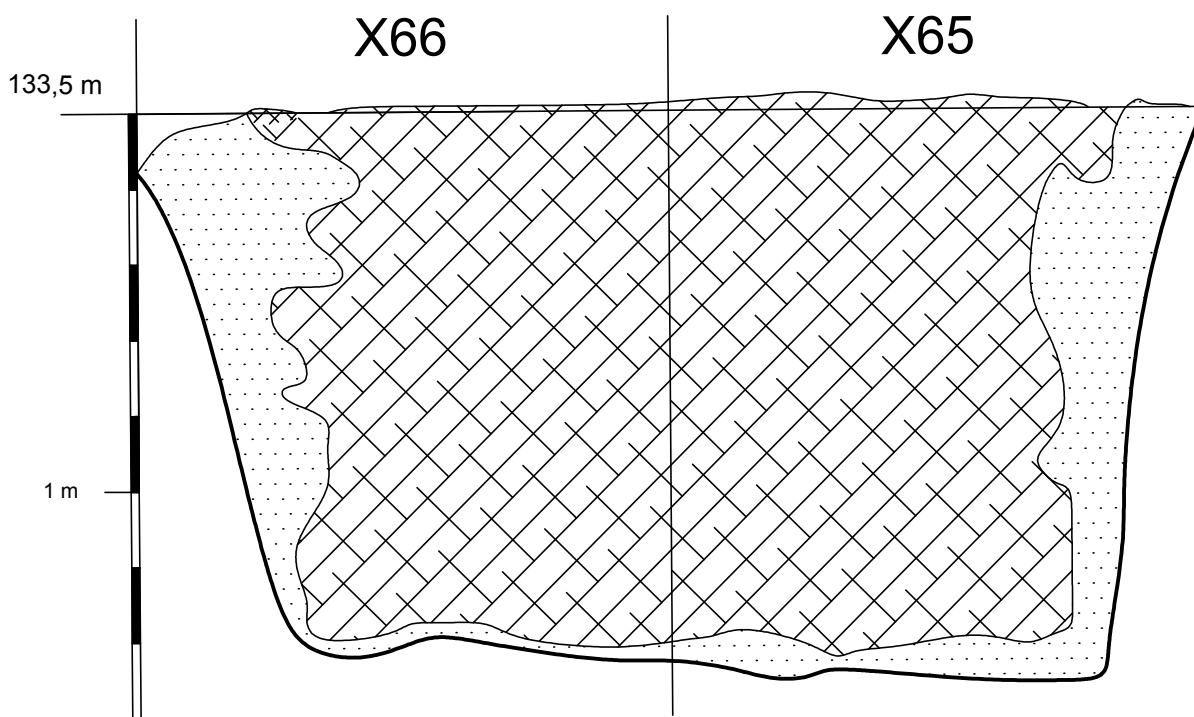

Obj. Nr. 173/4–174/1

M1:20

Brėžinys Nr. 111

Obj. Nr. 175/2

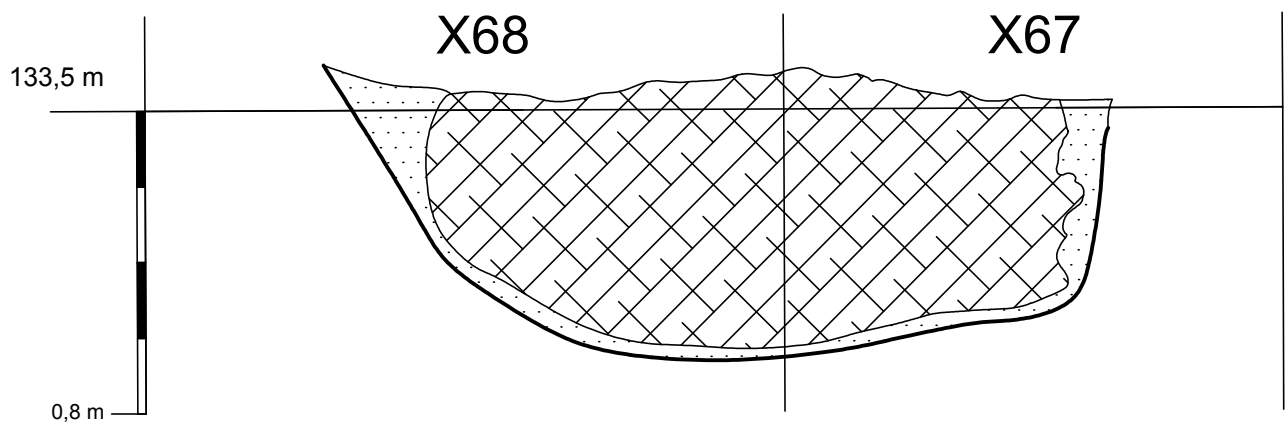

Obj. Nr. 175/2

M1:20

Brėžinys Nr. 112

P-25 P sienos pjūvis

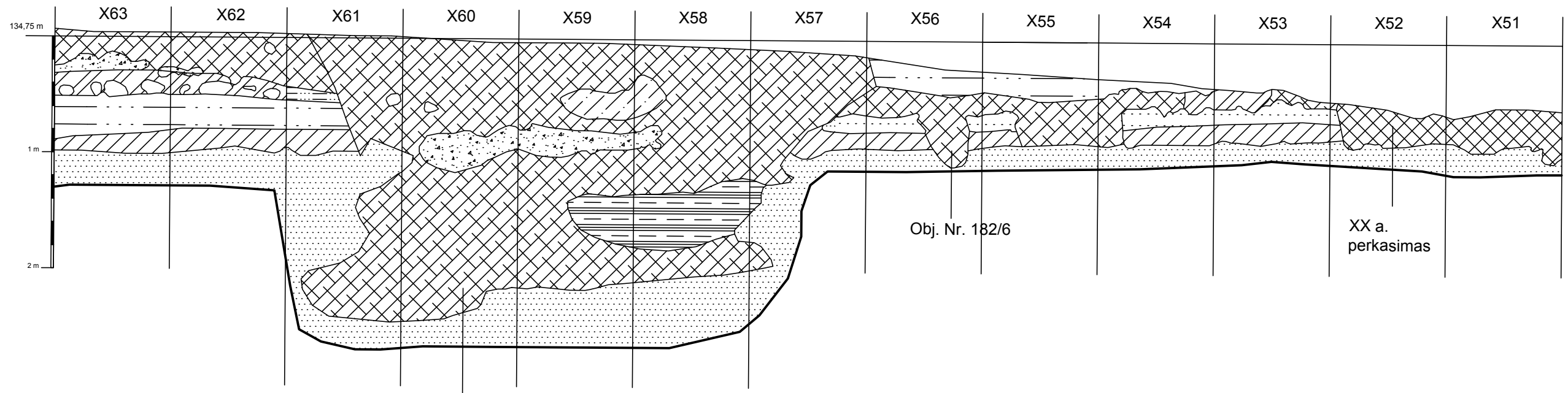

obj. Nr. 189/13

P-25 R sienos pjūvis

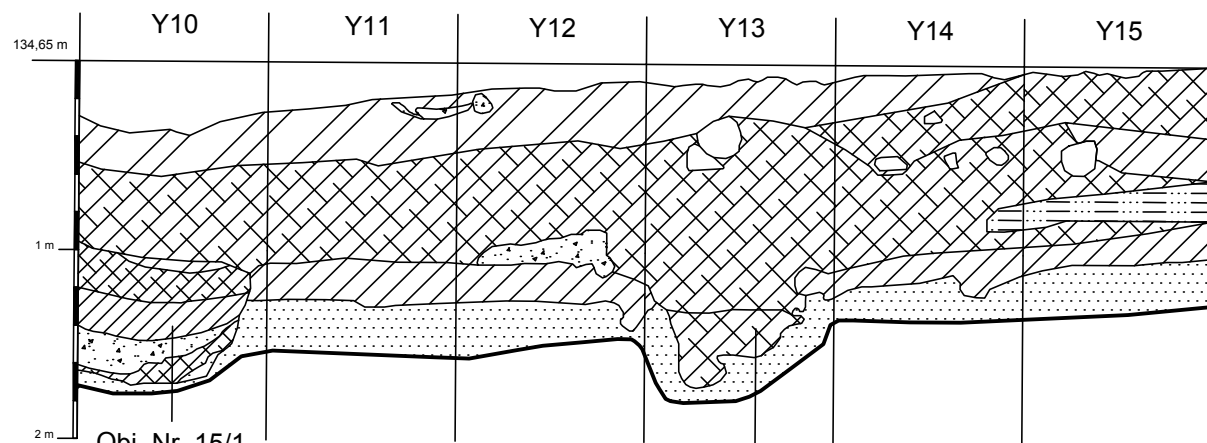

Obj. Nr. 106/7

P-26 P sienos pjūvis

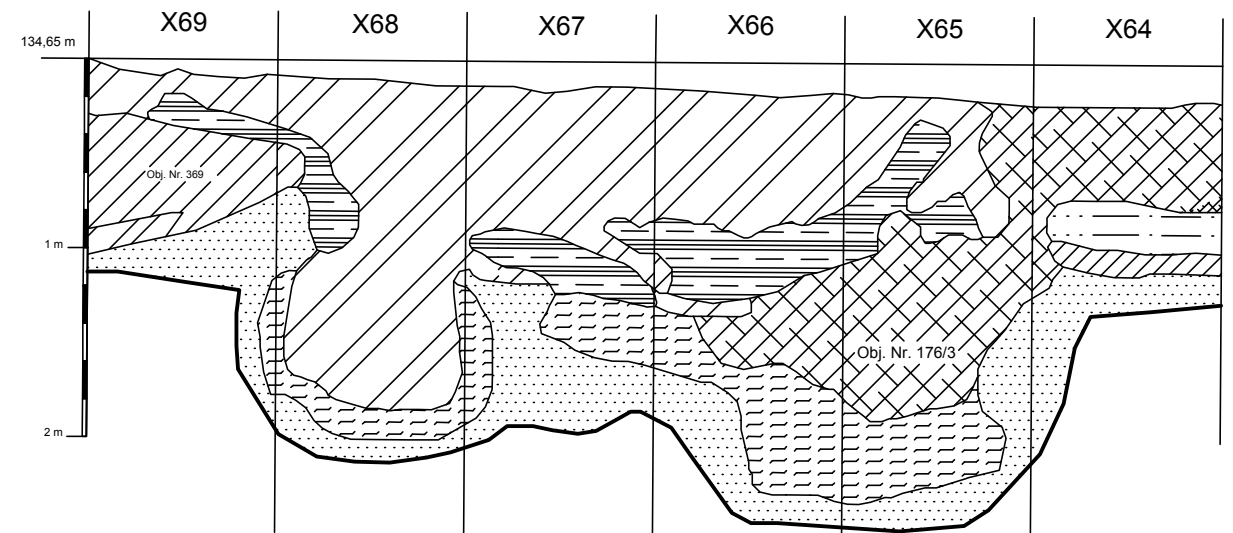

Obj. Nr. 176/3

P-26 R sienos pjūvis (Kv. Y14-Y15)

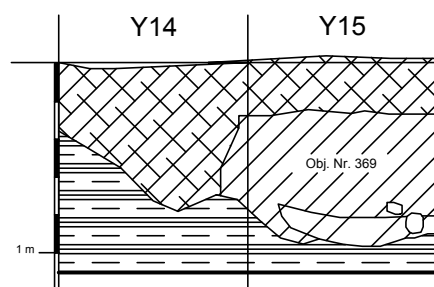

Obj. Nr. 369

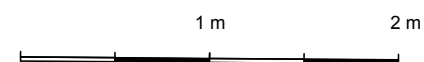

P-25 R, P sienų pjūviai;  
P-26 R (Kv. Y14-Y15), P-26 P sienų pjūviai

M1:40

Brėžinys Nr. 113

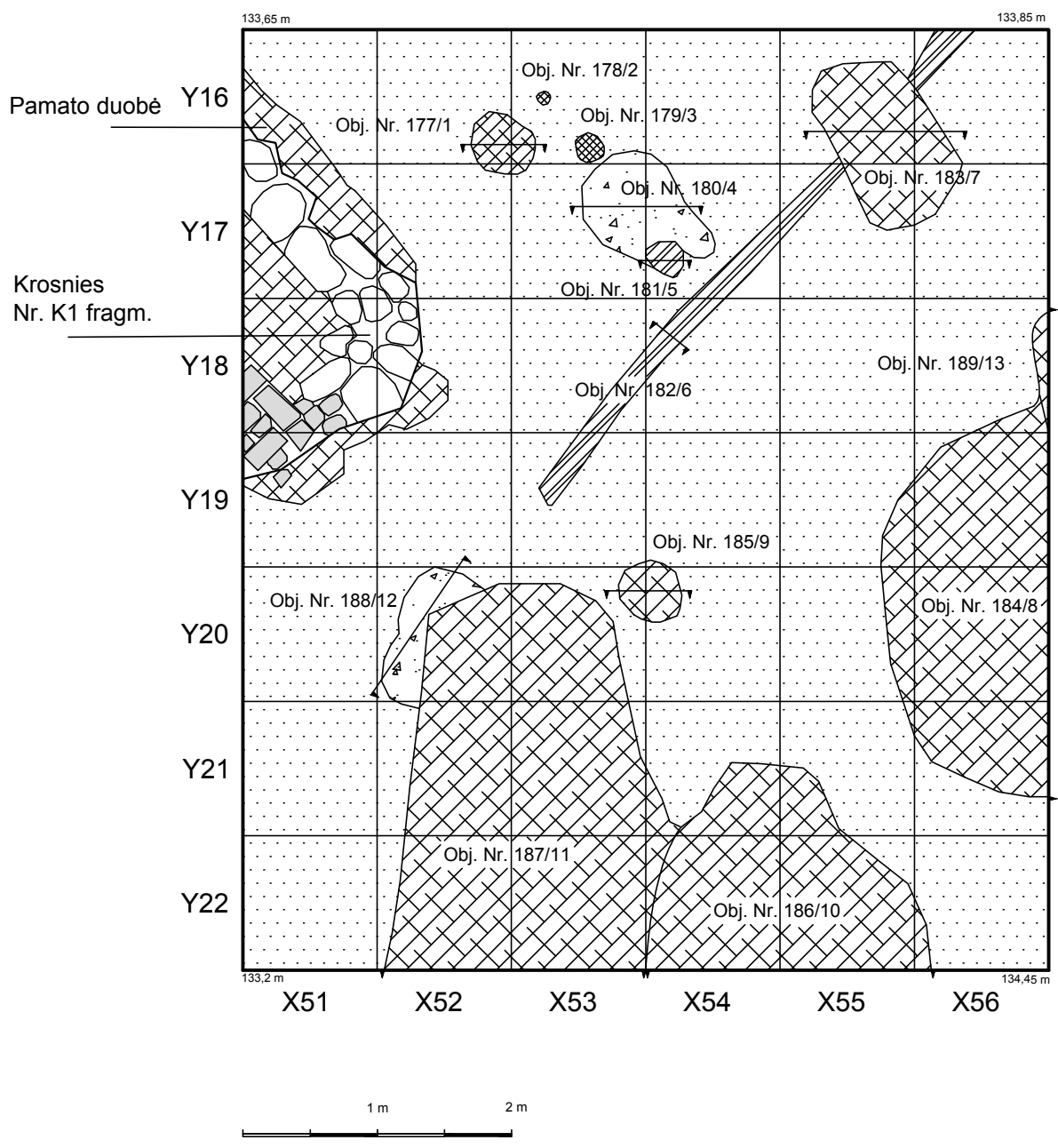

P-27 obj. sit. planas įžemėje (0,6 m gylis)

M1:50

Brėžinys Nr. 114

Obj. Nr. 177/1

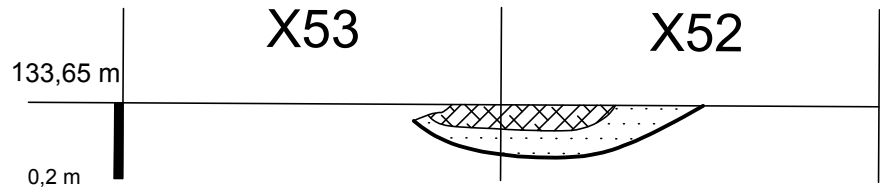

Obj. Nr. 180/4

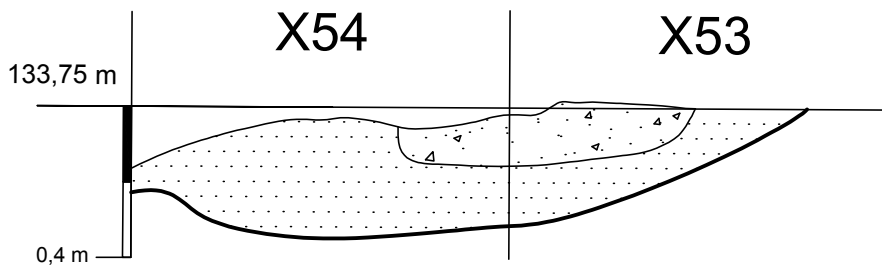

Obj. Nr. 181/5

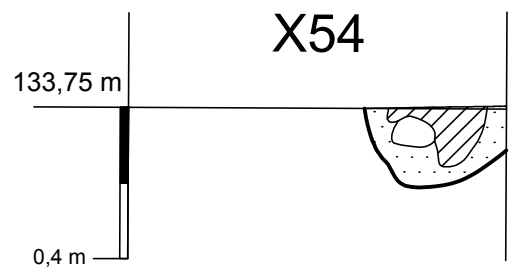

Obj. Nr. 183/7

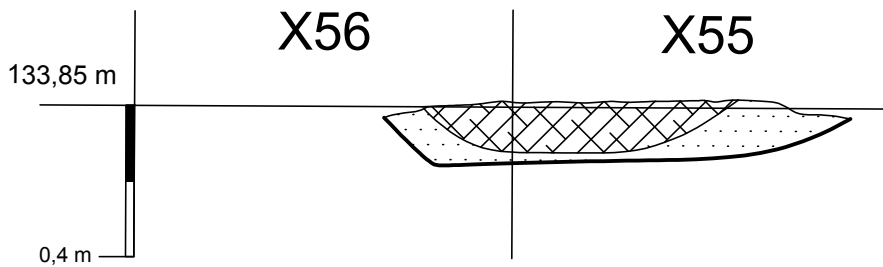

Obj. Nr. 185/9

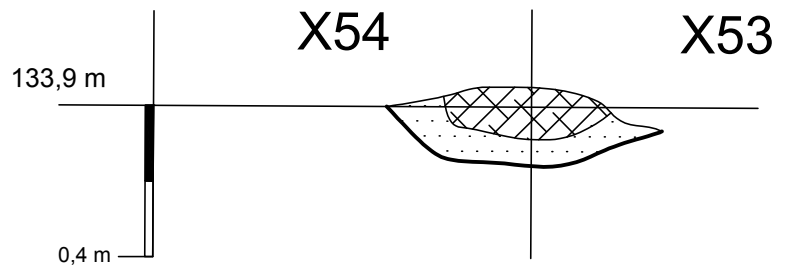

Obj. Nr. 182/6

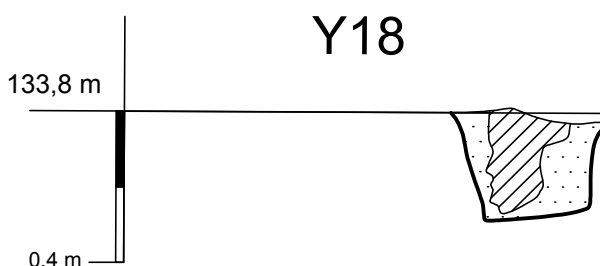

Obj. Nr. 177/1, 180/4–183/7, 185/9

M1:20

Brėžinys Nr. 115

P-27 R sienas pjūvis

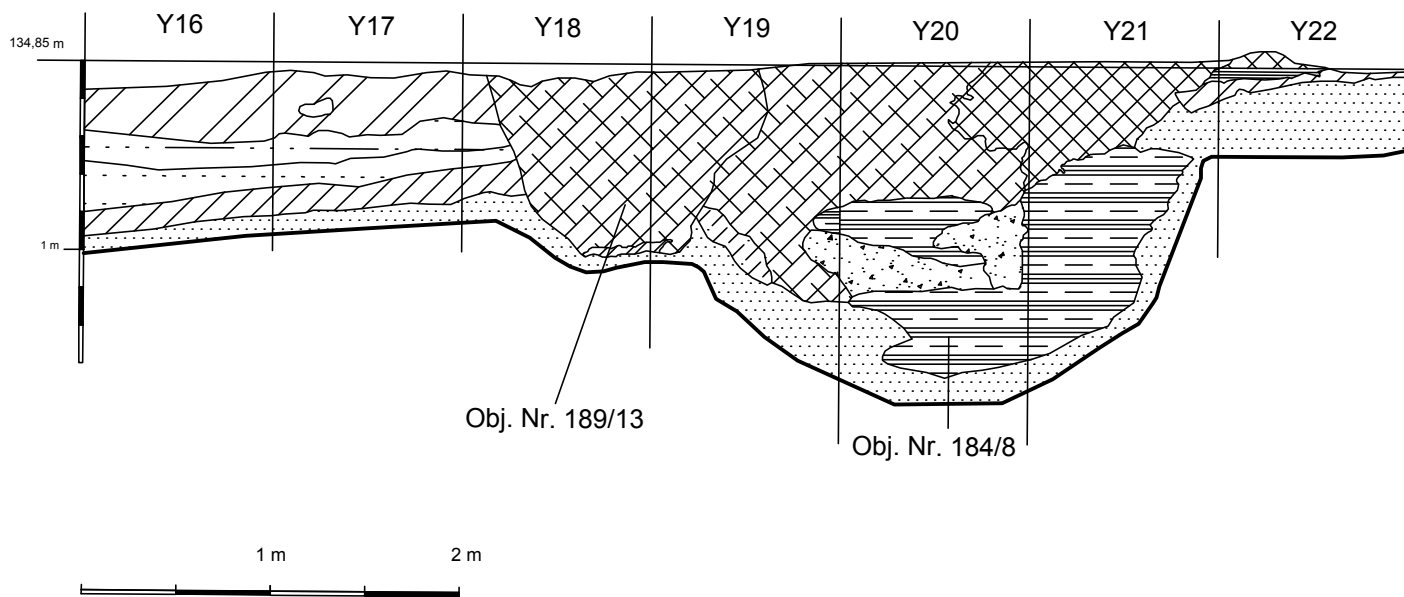

P-27 R sienas pjūvis

M1:40

Brēžinys Nr. 116



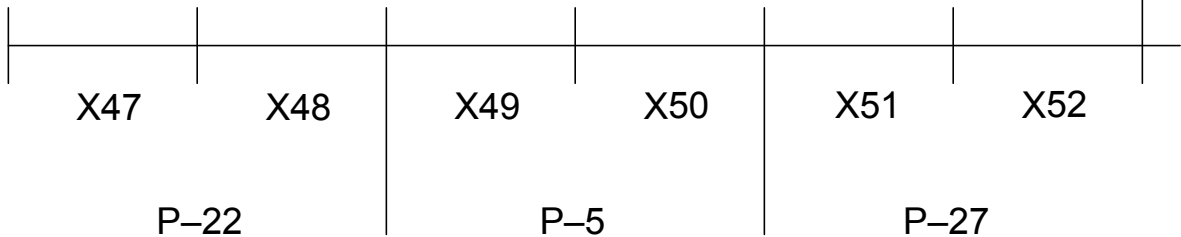
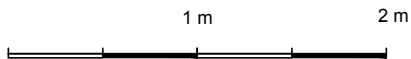
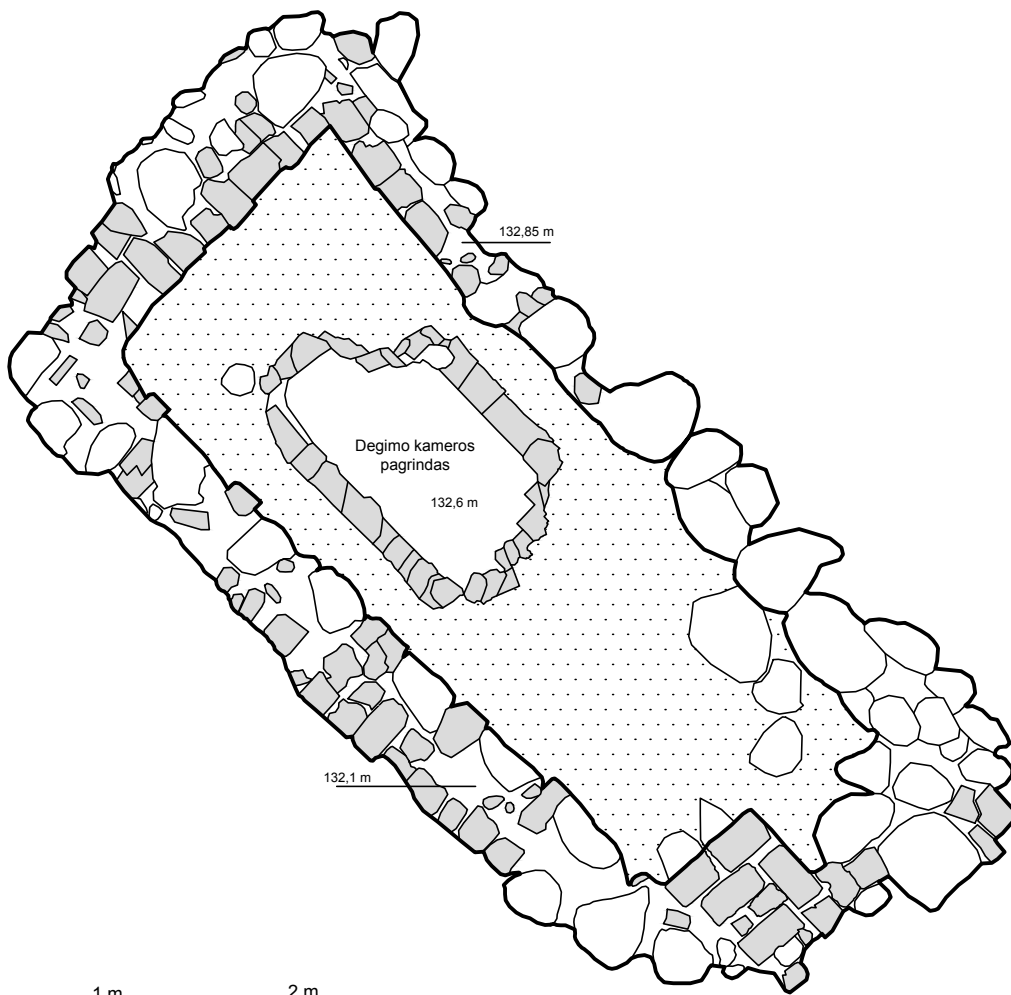

Krosnies Nr. K1 planas
M1:40
Brėžinys Nr. 117

P-28 t. p. ž. sluoksniu (XV a.) sit. planas (0,4 m gylis)

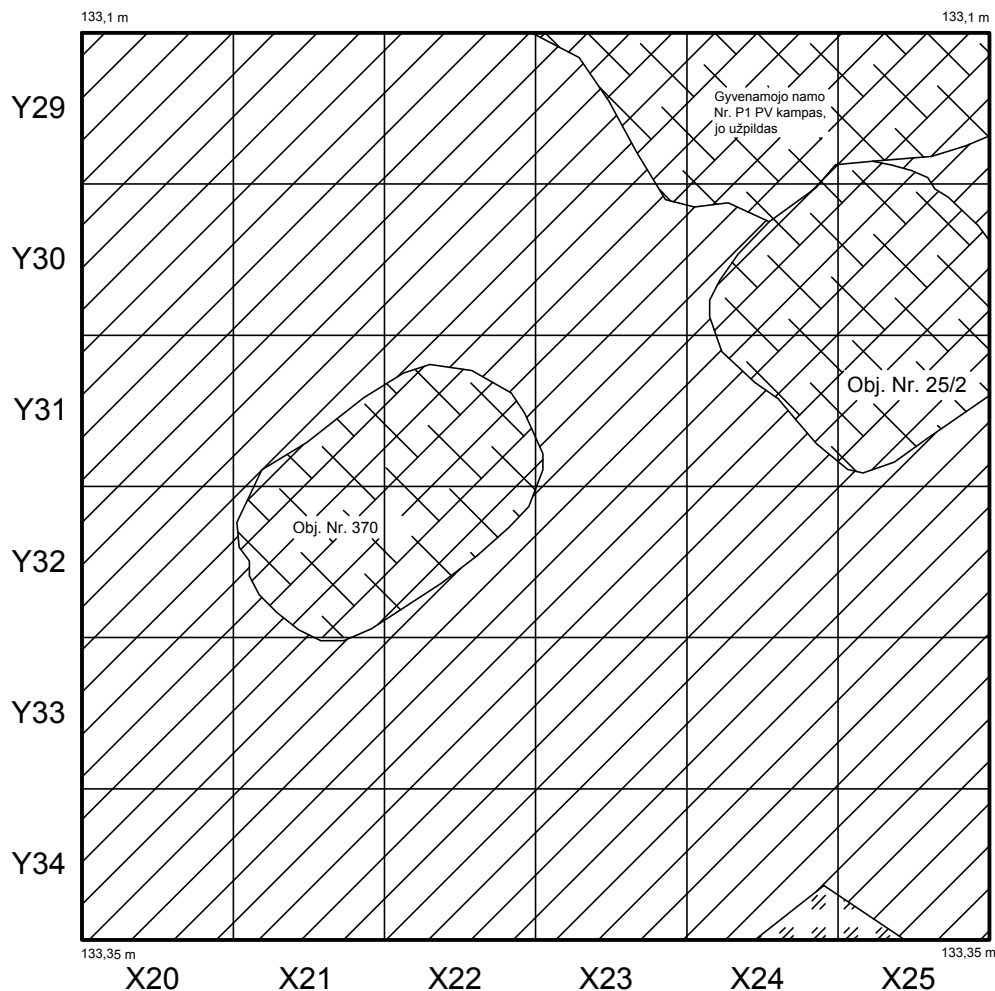

P-28 obj. sit. planas įžemyje (0,6 m gylis)

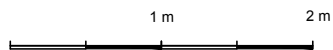
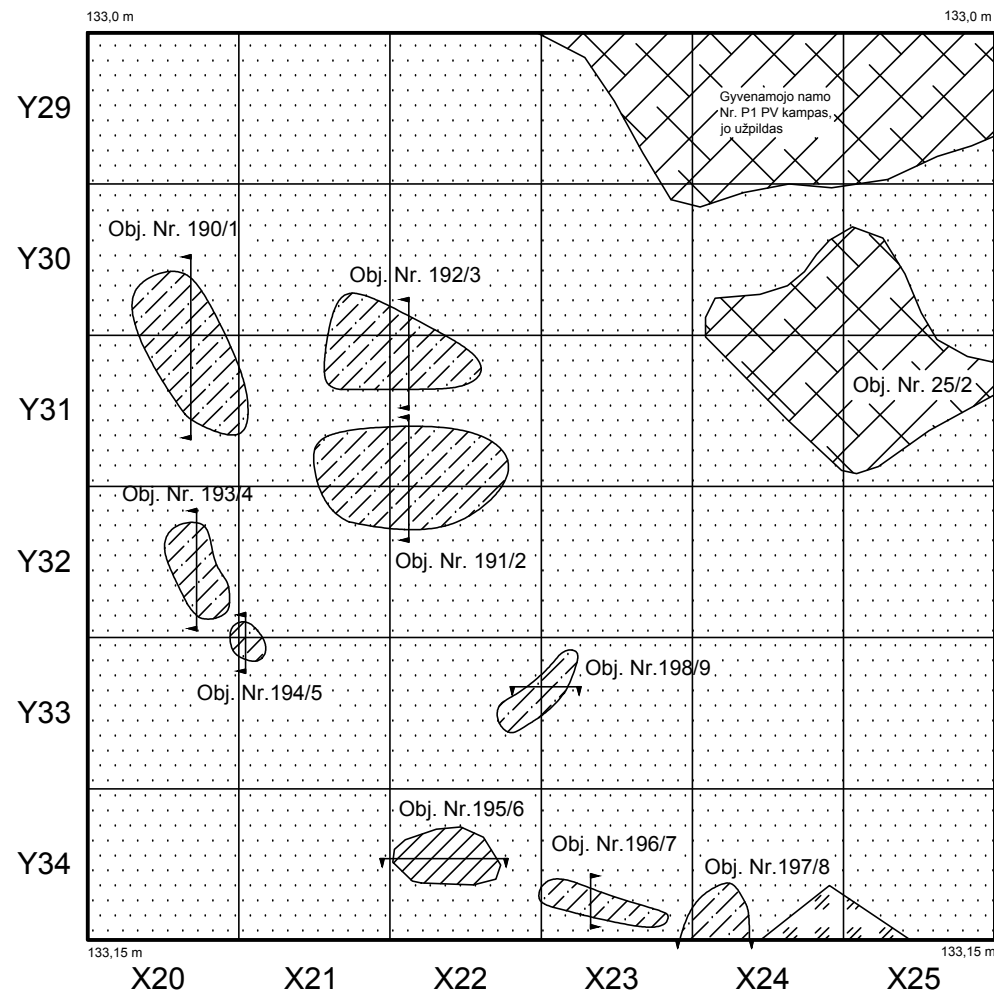

P-28 t. p. ž. sluoksniu (XV a.) sit. planas (0,4 m gylis);  
P-28 obj. sit. planas įžemyje (0,6 m gylis)

M1:50

Brėžinys Nr. 118

Obj. Nr. 190/1

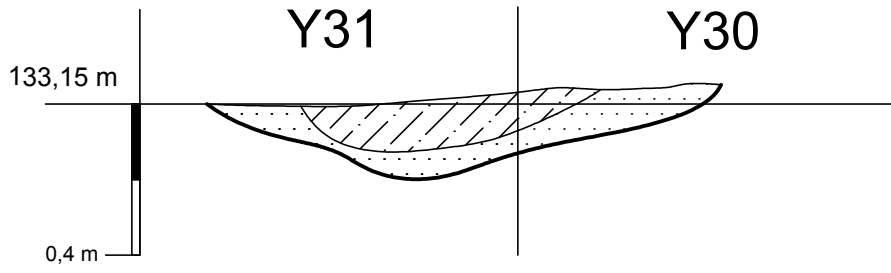

Obj. Nr. 193/4

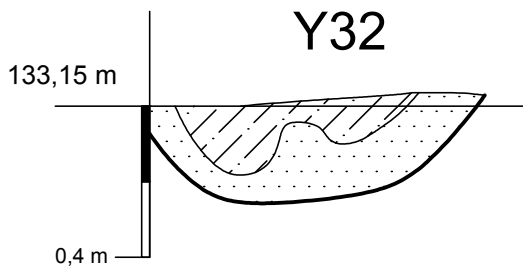

Obj. Nr. 194/5

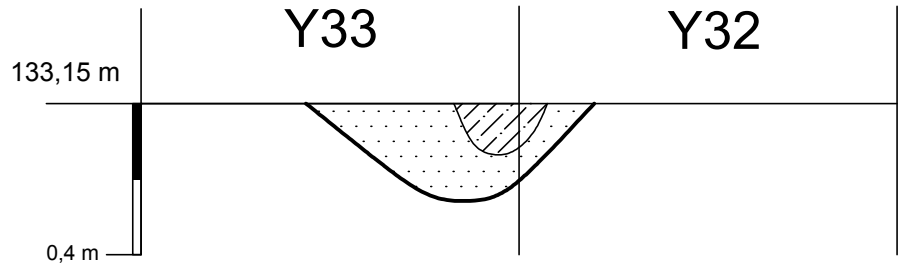

Obj. Nr. 195/6

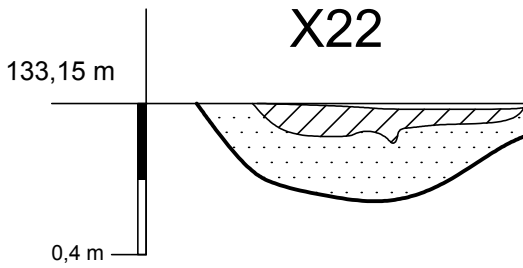

Obj. Nr. 198/9

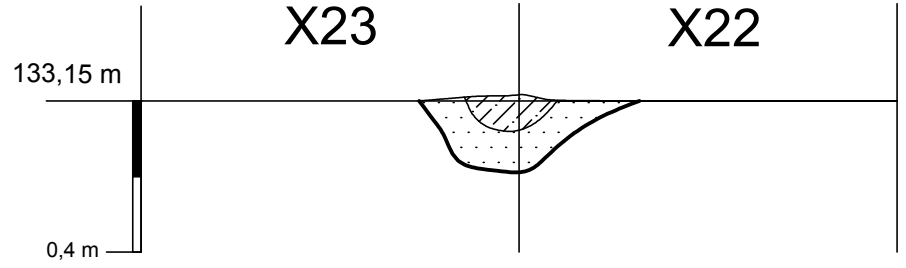

Obj. Nr. 190/1–198/9
M1:20
Brėžinys Nr. 119

P-29 t. p. ž. sluoksniu (XV a.) sit. planas  
(0,3–0,45 m gylis)

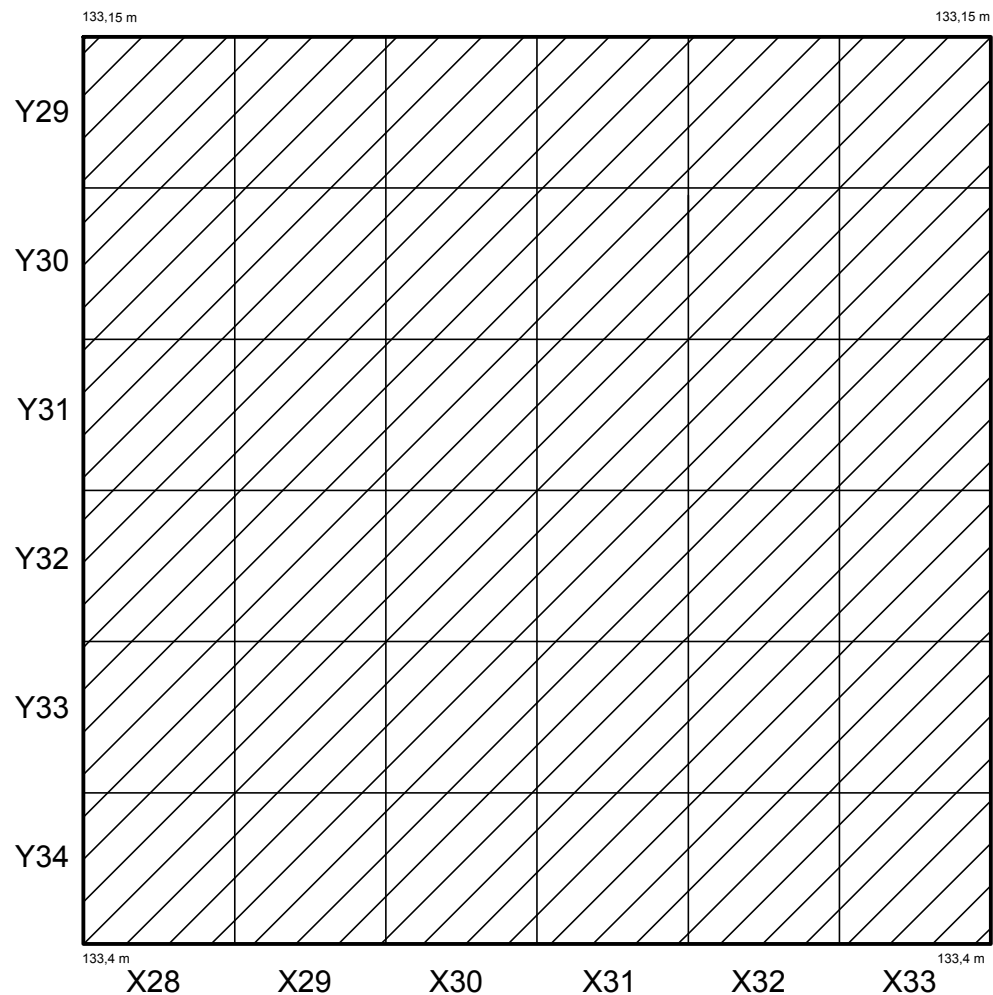

P-29 obj. sit. planas įžemyje (0,5–0,55 m gylis)

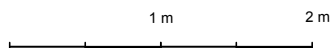
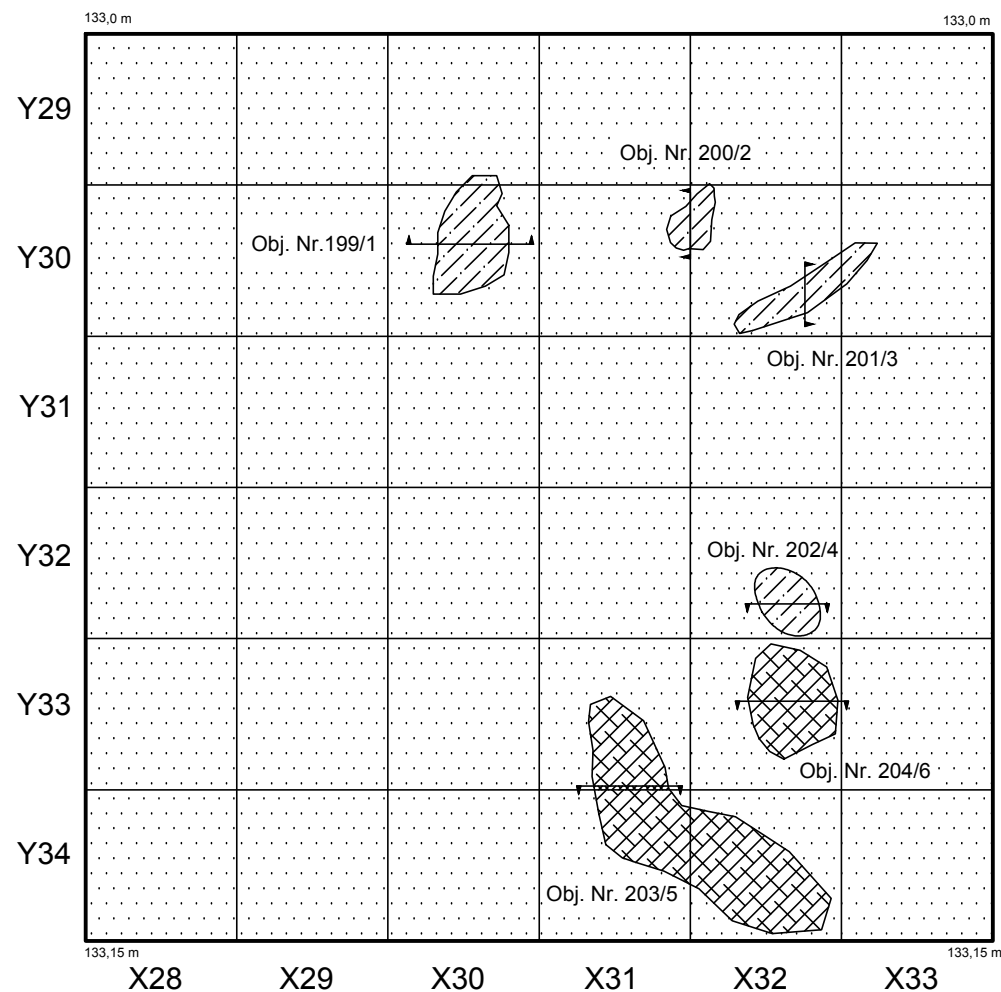

P-29 t. p. ž. sluoksniu (XV a.) sit. planas (0,3–0,45 m gylis);  
P-29 obj. sit. planas įžemyje (0,5–0,55 m gylis)

M1:50

Brėžinys Nr. 120

Obj. Nr. 199/1

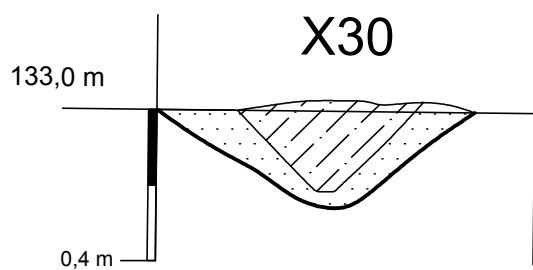

Obj. Nr. 200/2

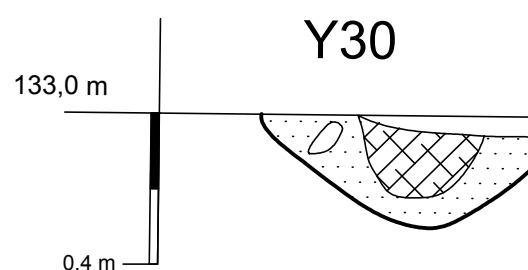

Obj. Nr. 203/5

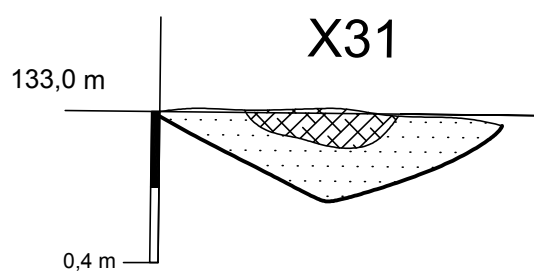

Obj. Nr. 204/6

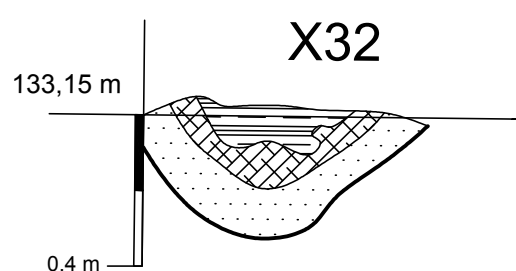

Obj. Nr. 199/1–204/6

M1:20

Brėžinys Nr. 121

P-28 P sienos pjūvis

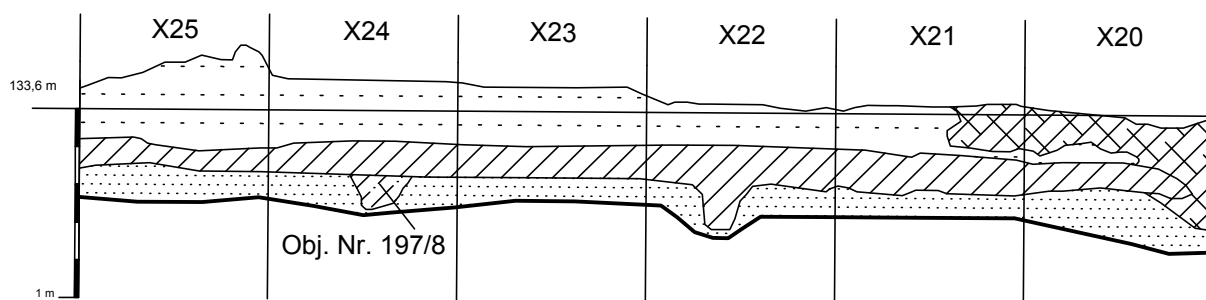

P-28 V sienos pjūvis

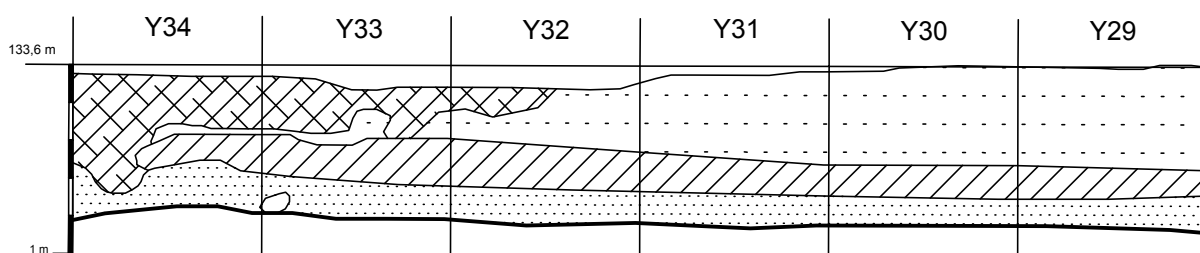

P-29 R sienos pjūvis

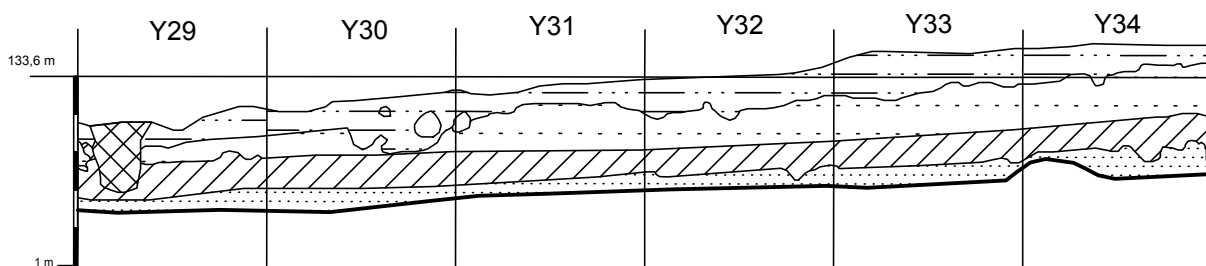

P-29 P sienos pjūvis

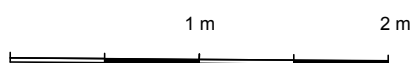
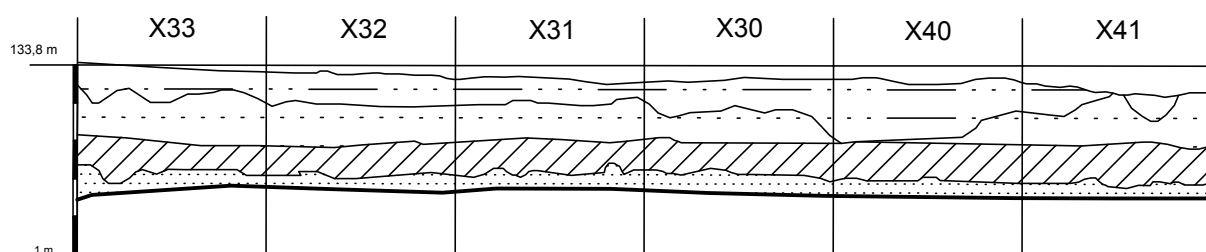

P-28 P, V sienų pjūviai; P-29 R, P sienų pjūviai

M1:40

Brėžinys Nr. 122

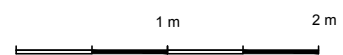
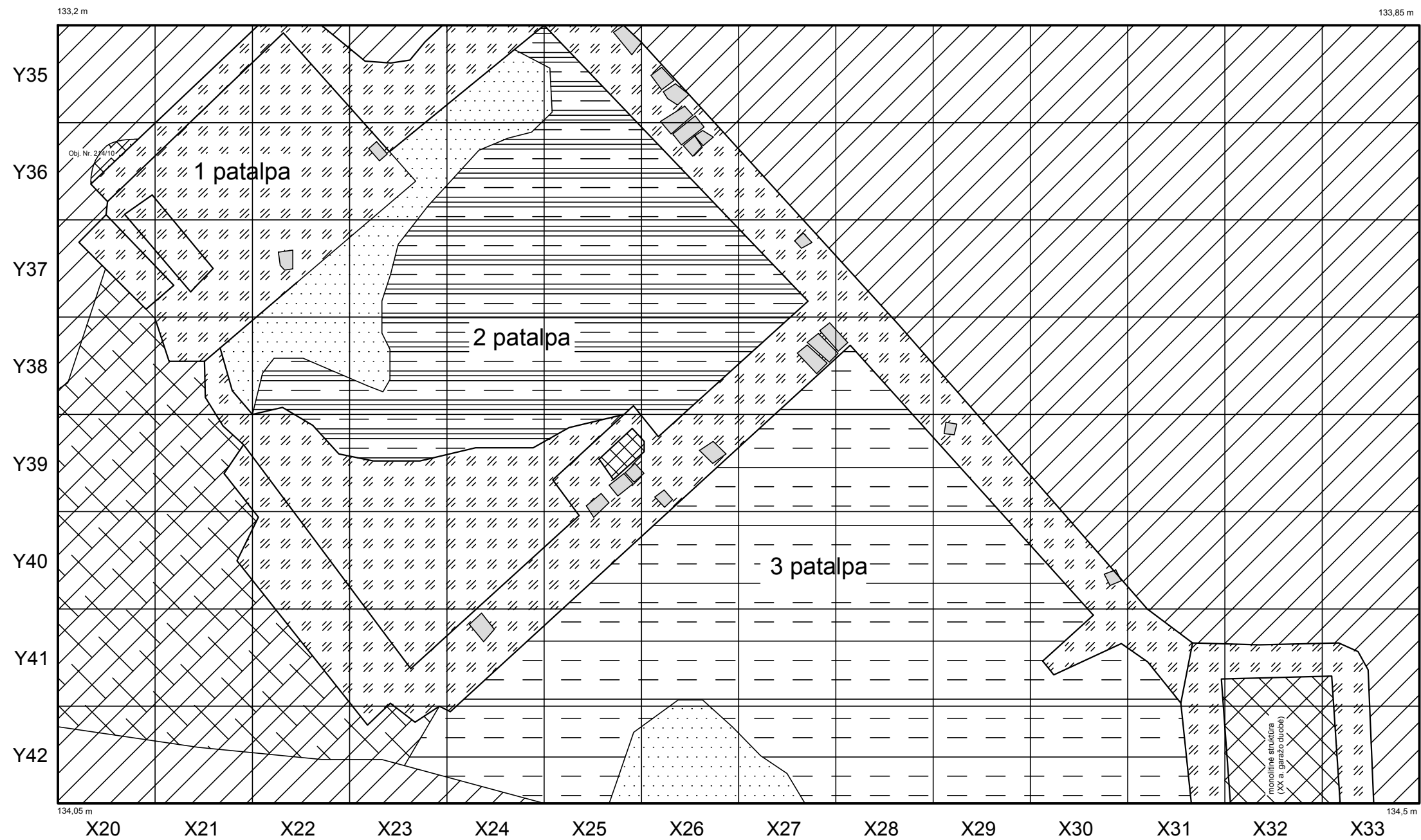

P-30 t. p. ž. sluoksniu (XV a.) sit. planas (0,15-0,2 m gylis);  
Gyvenamojo namo Nr. P3 sit. planas

M1:50

Brėžinys Nr. 123

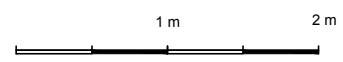
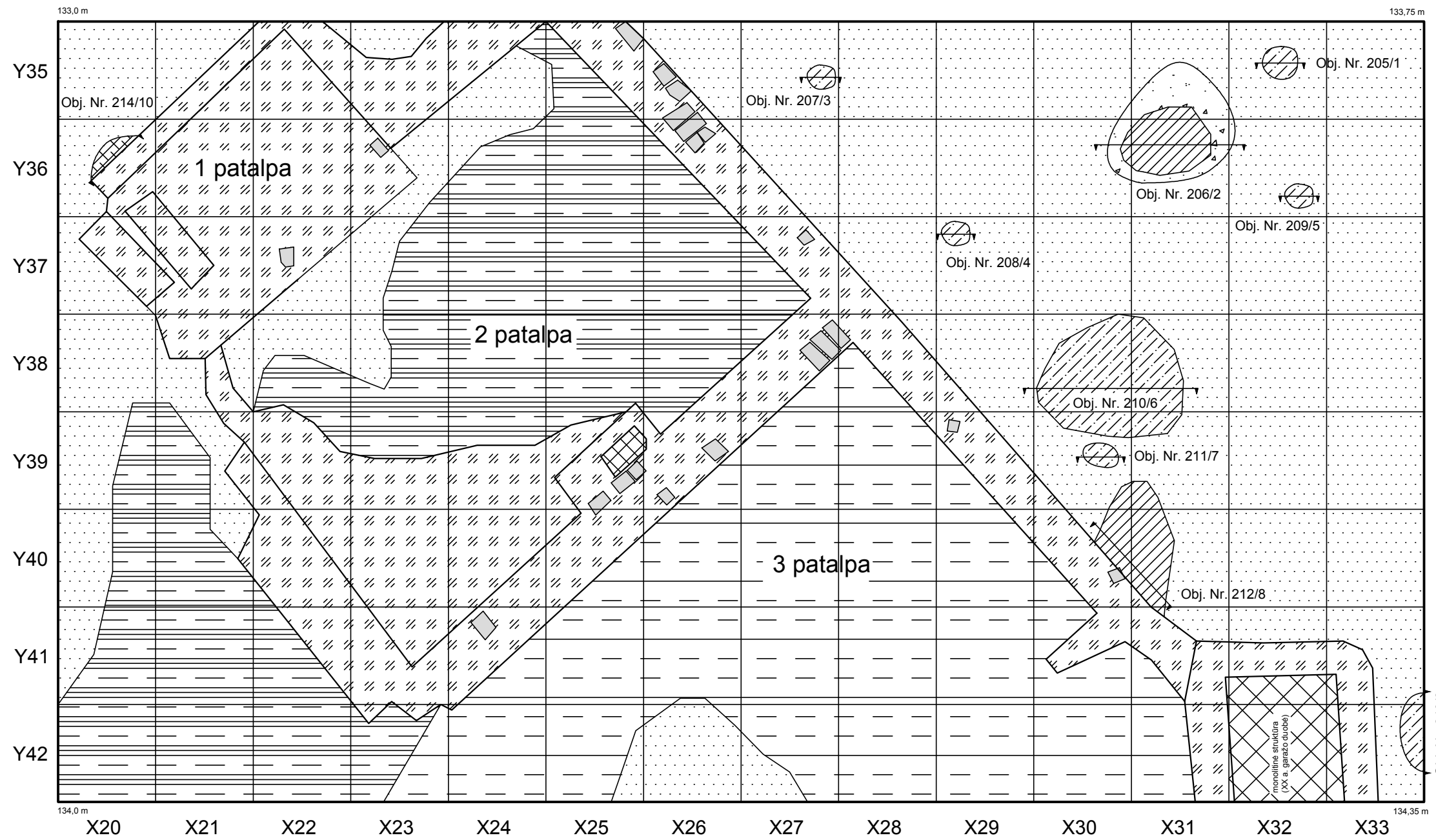

P-30 obj. sit. planas įžemyje (0,3–0,4 m gylis);  
Gyvenamojo namo Nr. P3 sit. planas

M1:50

Brėžinys Nr. 124



Obj. Nr. 205/1

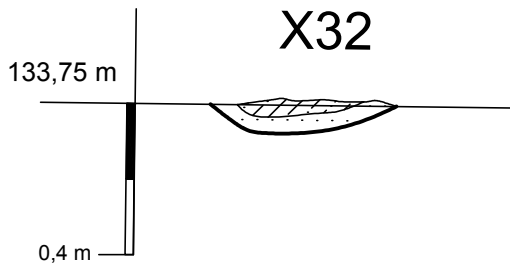

Obj. Nr. 206/2

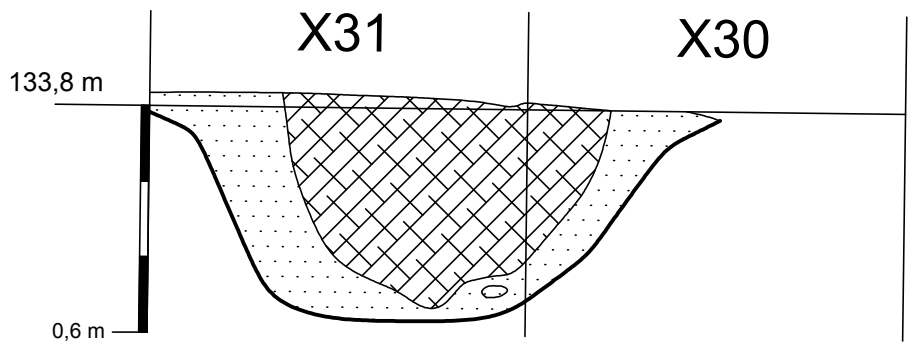

Obj. Nr. 209/5

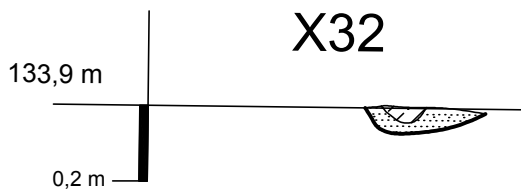

Obj. Nr. 211/7

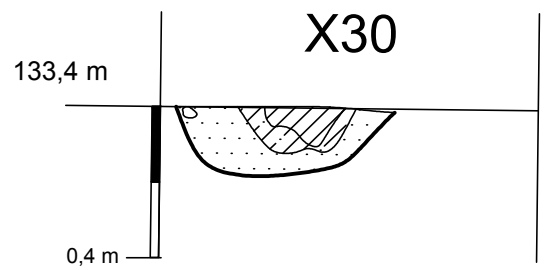

Obj. Nr. 212/8

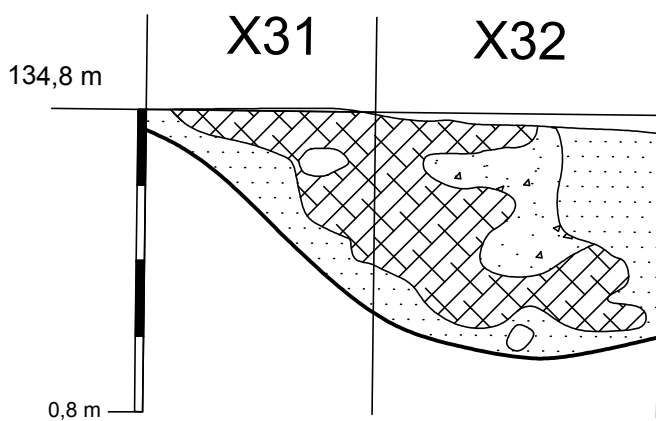

Obj. Nr. 205/1–206/2, 209/5, 211/7–212/8

M1:20

Brėžinys Nr. 125

P- 30 R sienos pjūvis

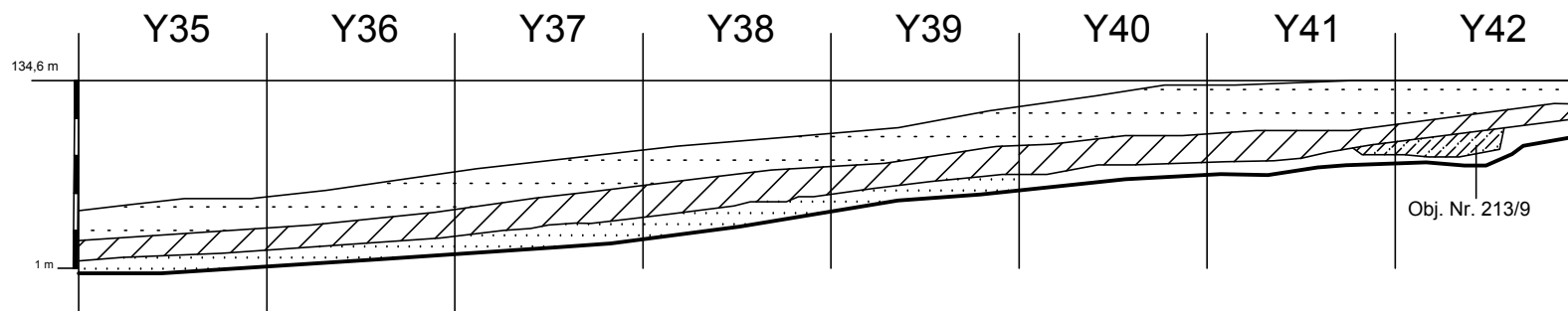

P- 30 P sienos pjūvis (Kv. X33)

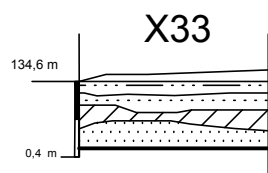

P- 30 P sienos pjūvis (Kv. X25-X20)

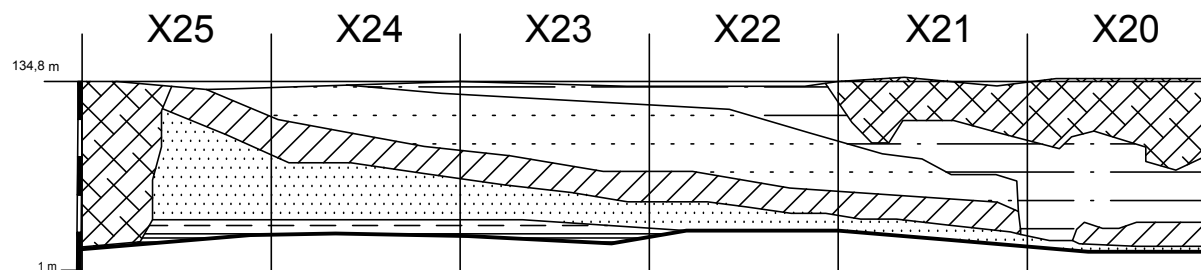

P- 30 V sienos pjūvis (Kv. Y38-Y35)

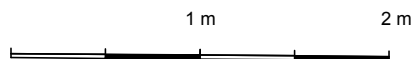
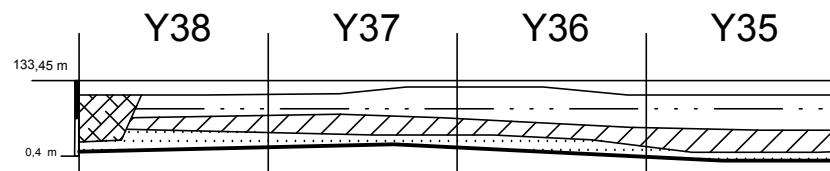

P-30 R sienos pjūvis;  
P-30 P sienos pjūvis (Kv. X33, Kv. X25-X20);  
P-30 V sienos pjūvis (Kv. Y38-Y35)

M1:40

Brēžinys Nr. 126

P-31 sit. planas (0,15–0,2 m gylis)

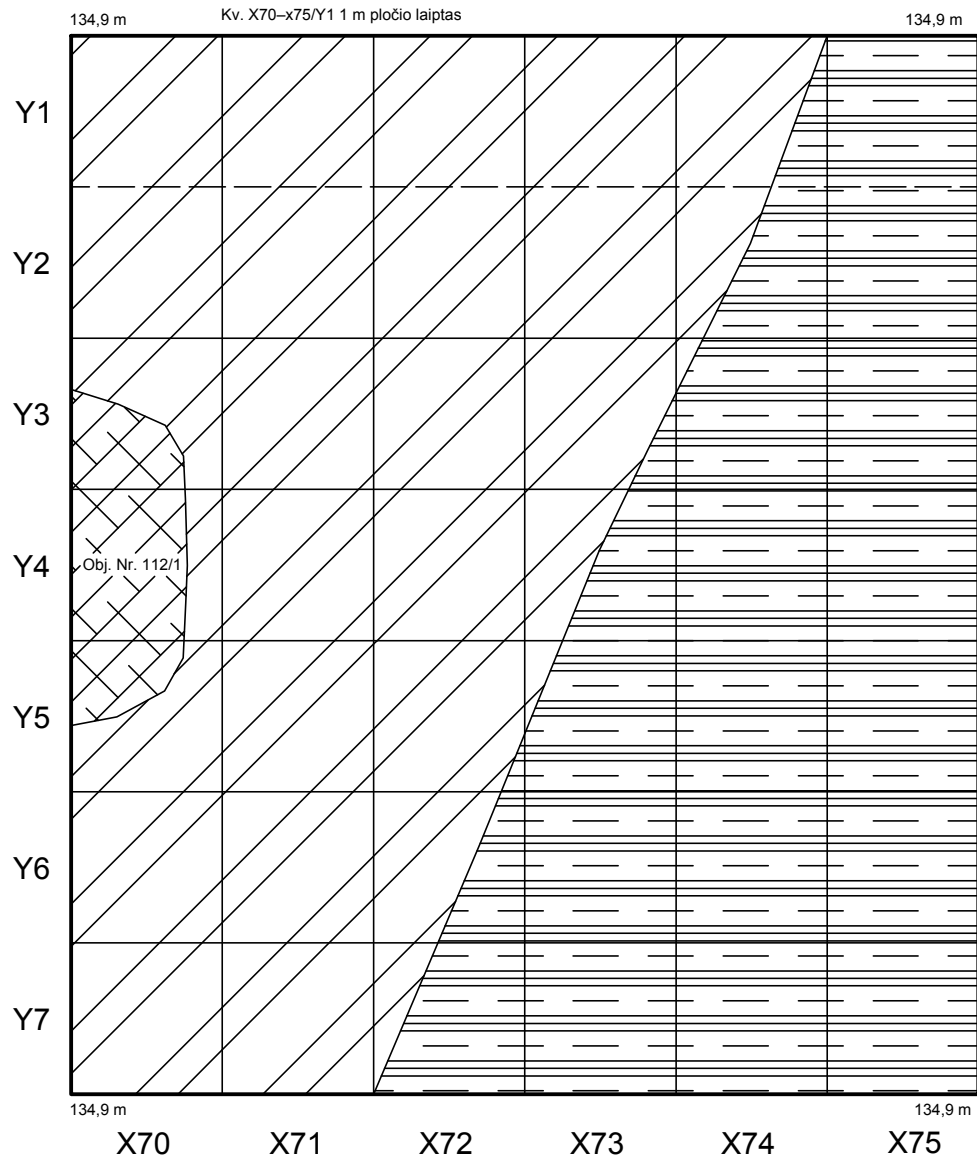

P-31 obj. sit. planas žemyje (0,15–0,6 m gylis)

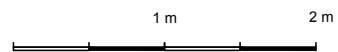
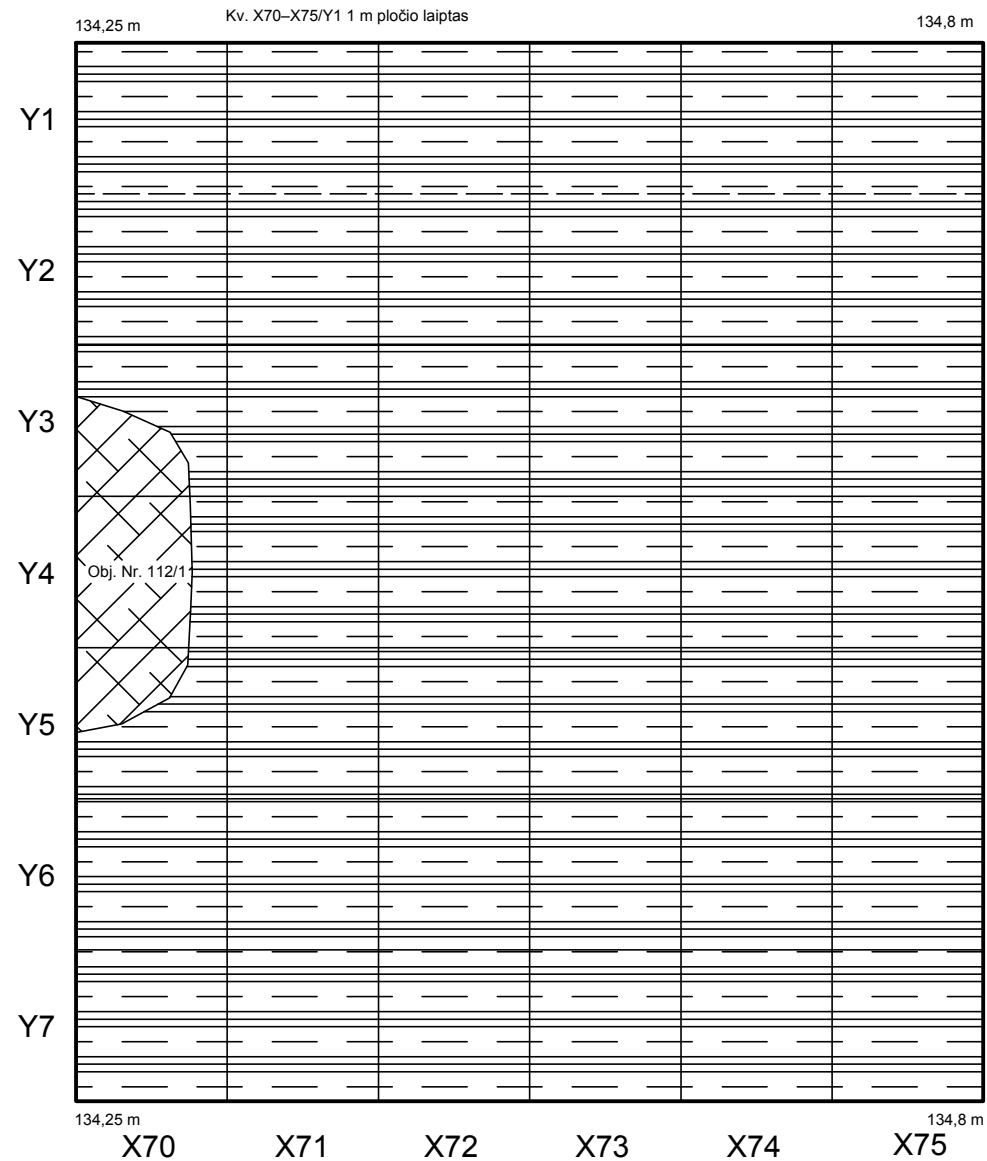

P-31 sit. planas (0,15–0,2 m gylis);  
P-31 obj. sit. planas žemyje (0,15–0,6 m gylis)

M1:50

Brėžinys Nr. 127

P- 31 Š sienos pjūvis

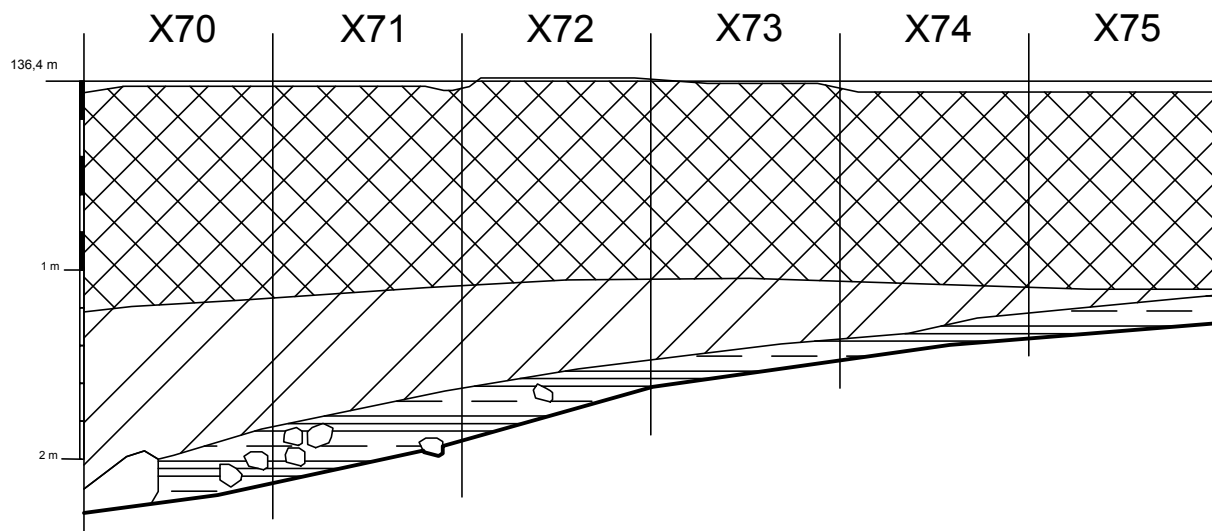

P- 31 P sienos pjūvis

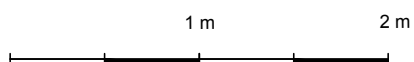
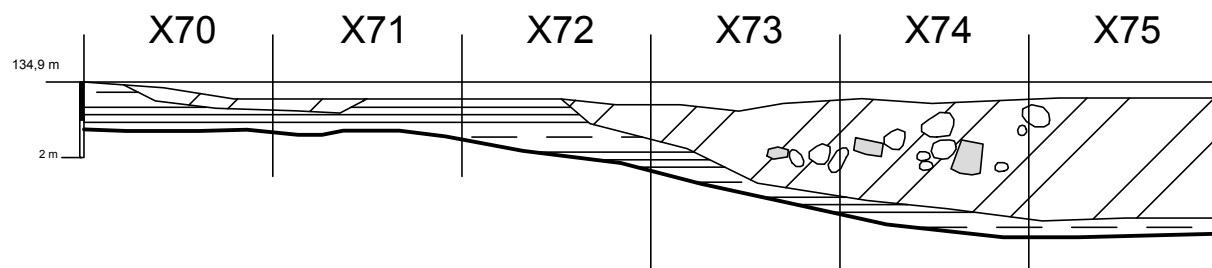

P-31 Š, P sienų pjūviai

M1:40

Brėžinys Nr. 128

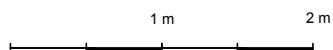
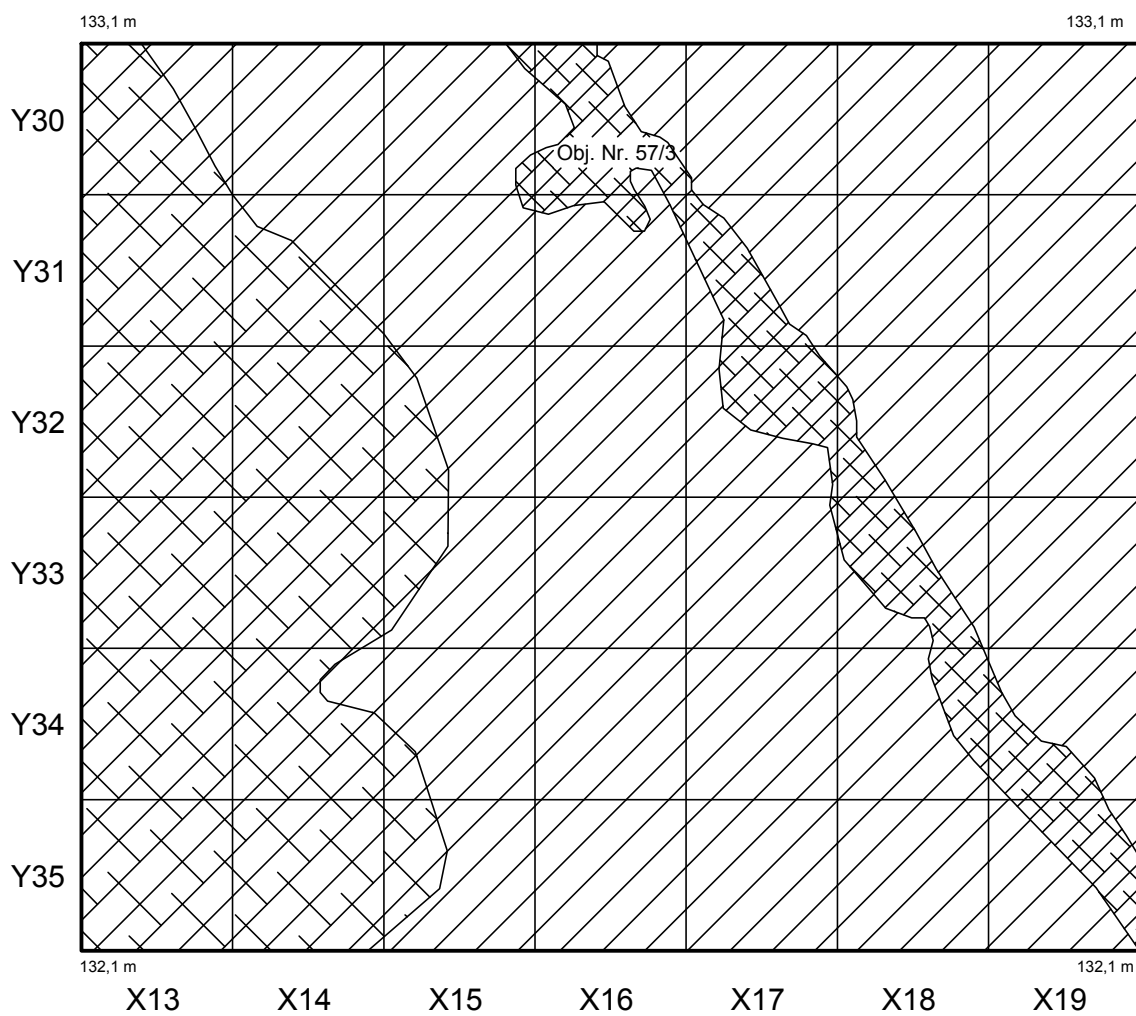

P-32 t. p. ž. sluoksniu (XV a.) sit. planas (0,4 m gylis)

M1:50

Brėžinys Nr. 129

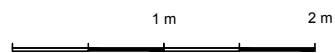
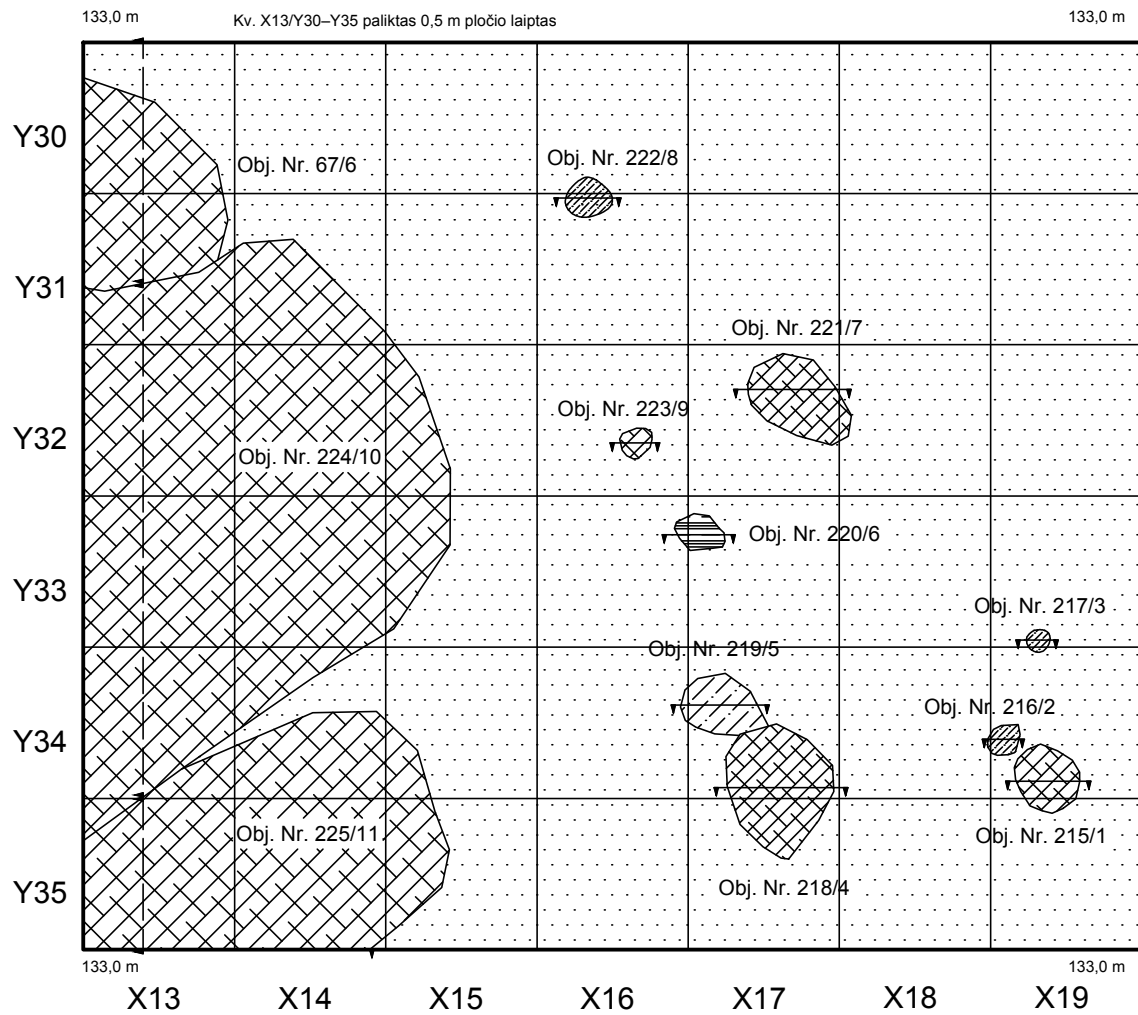

P-32 obj. sit. planas įžemyje (0,5–0,6 m gylis)

M1:50

Brėžinys Nr. 130

Obj. Nr. 215/1

Obj. Nr. 216/2

Obj. Nr. 218/4

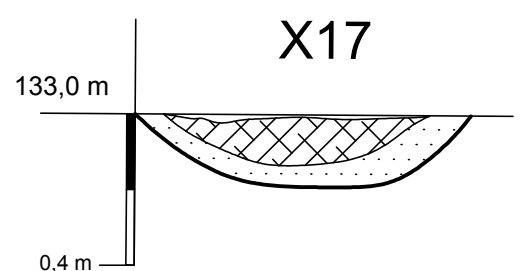
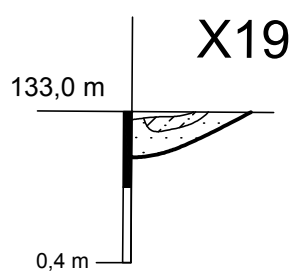
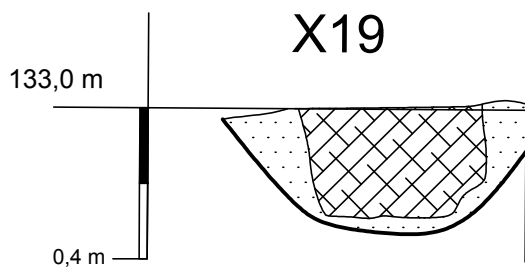

Obj. Nr. 219/5

Obj. Nr. 220/6

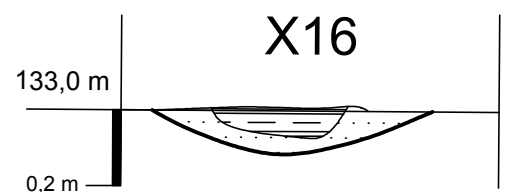
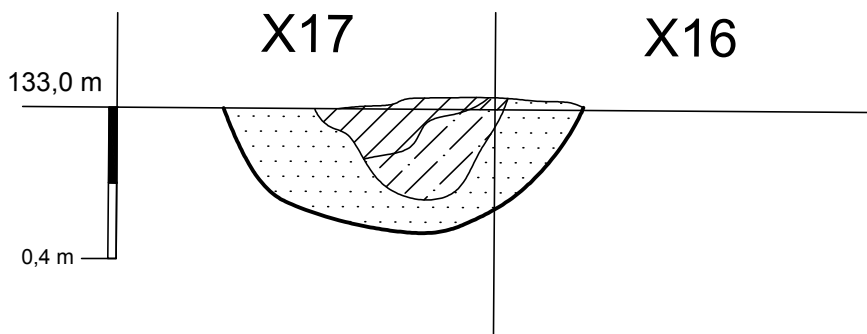

Obj. Nr. 221/7

Obj. Nr. 222/8

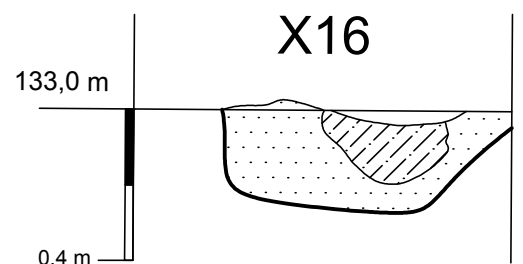
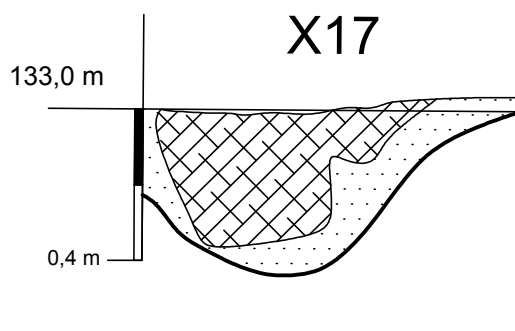

Obj. Nr. 223/9

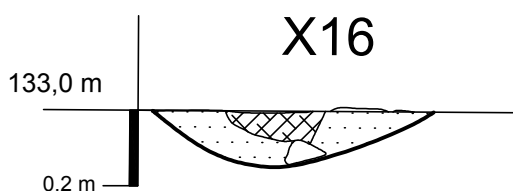

Obj. Nr. 215/1–216/2, 218/4–223/9

M1:20

Brėžinys Nr. 131

Obj. Nr. 225/11

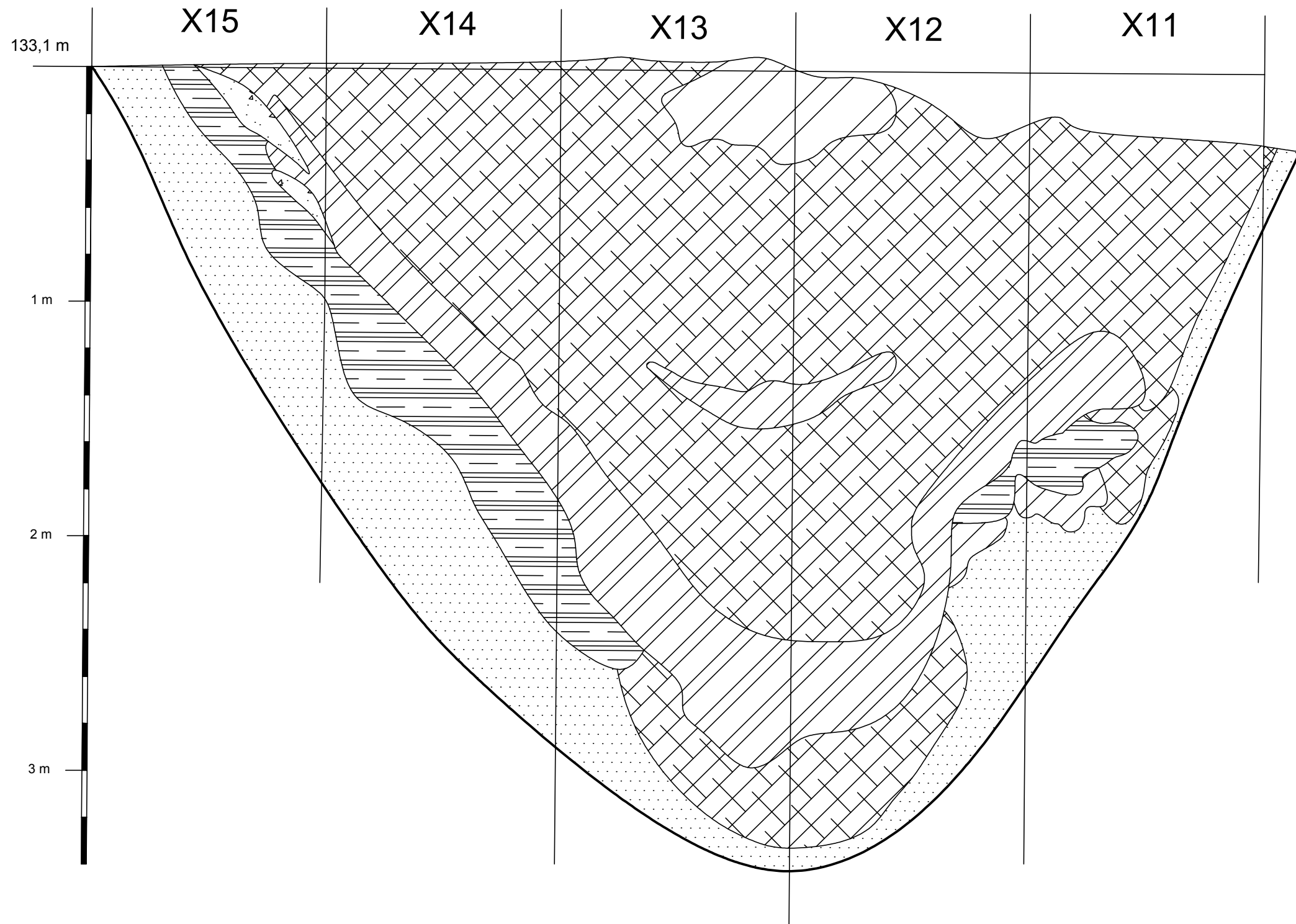

Obj. Nr. 225/11

M1:20

Brėžinys Nr. 132



P-32 P sienos pjūvis

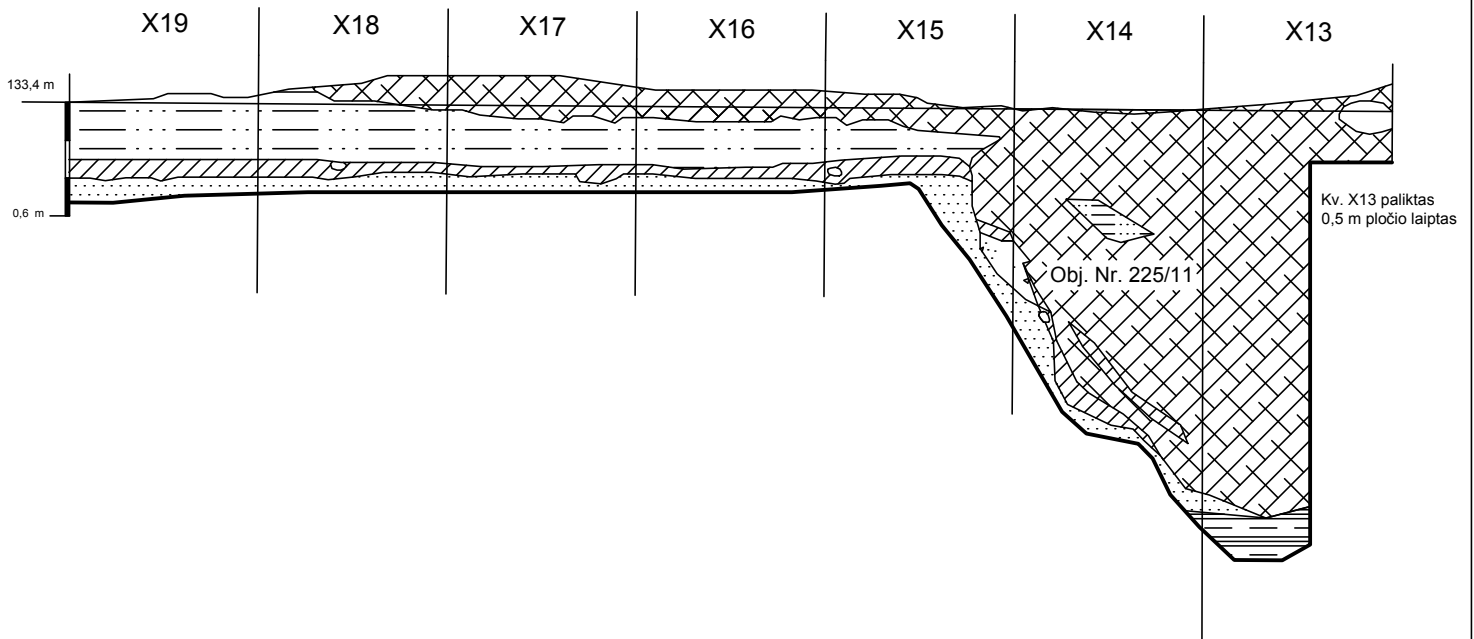

P-32 V sienos pjūvis

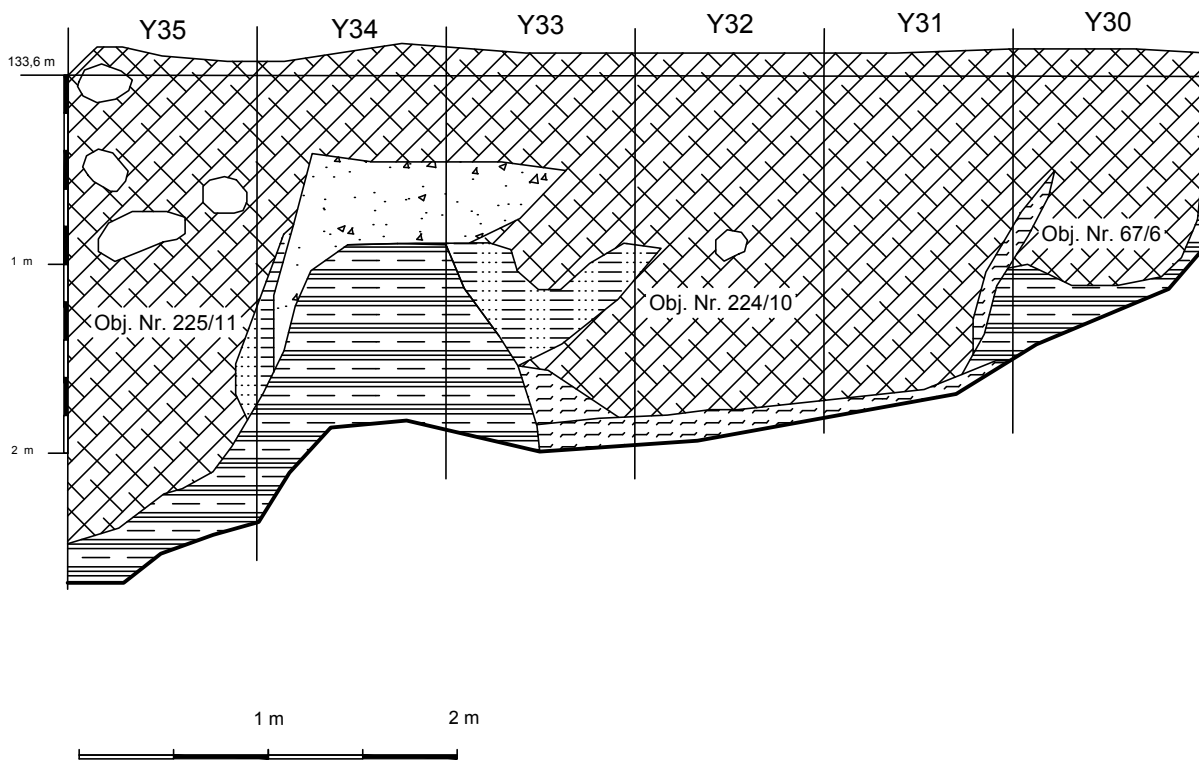

P-32 P, V sienų pjūviai

M1:40

Brėžinys Nr. 133

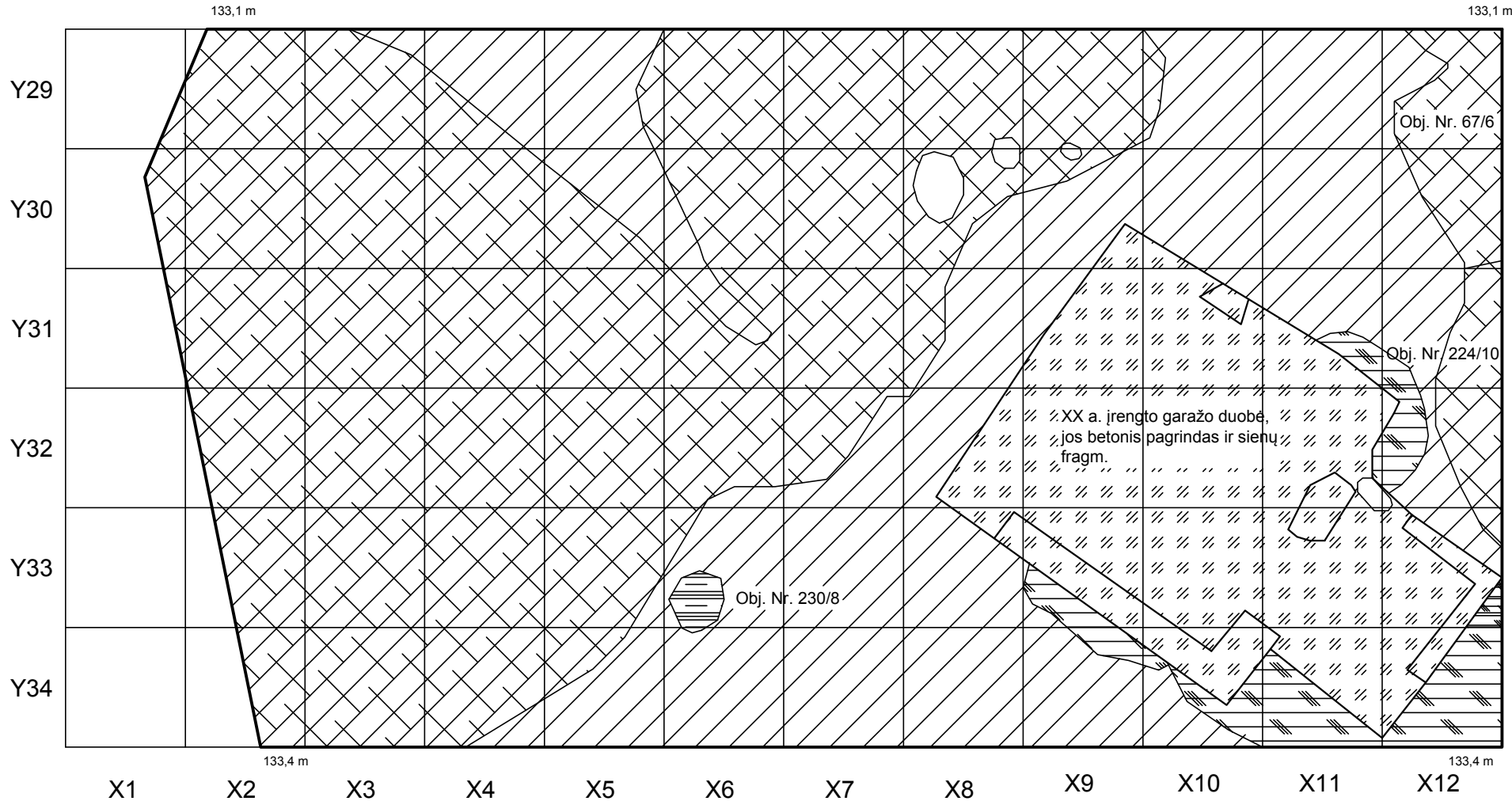

P-33 t. p. ž. sluoksnio (XV a.) sit. planas (0,2 m gylis)

M1:50

Brėžinys Nr. 134

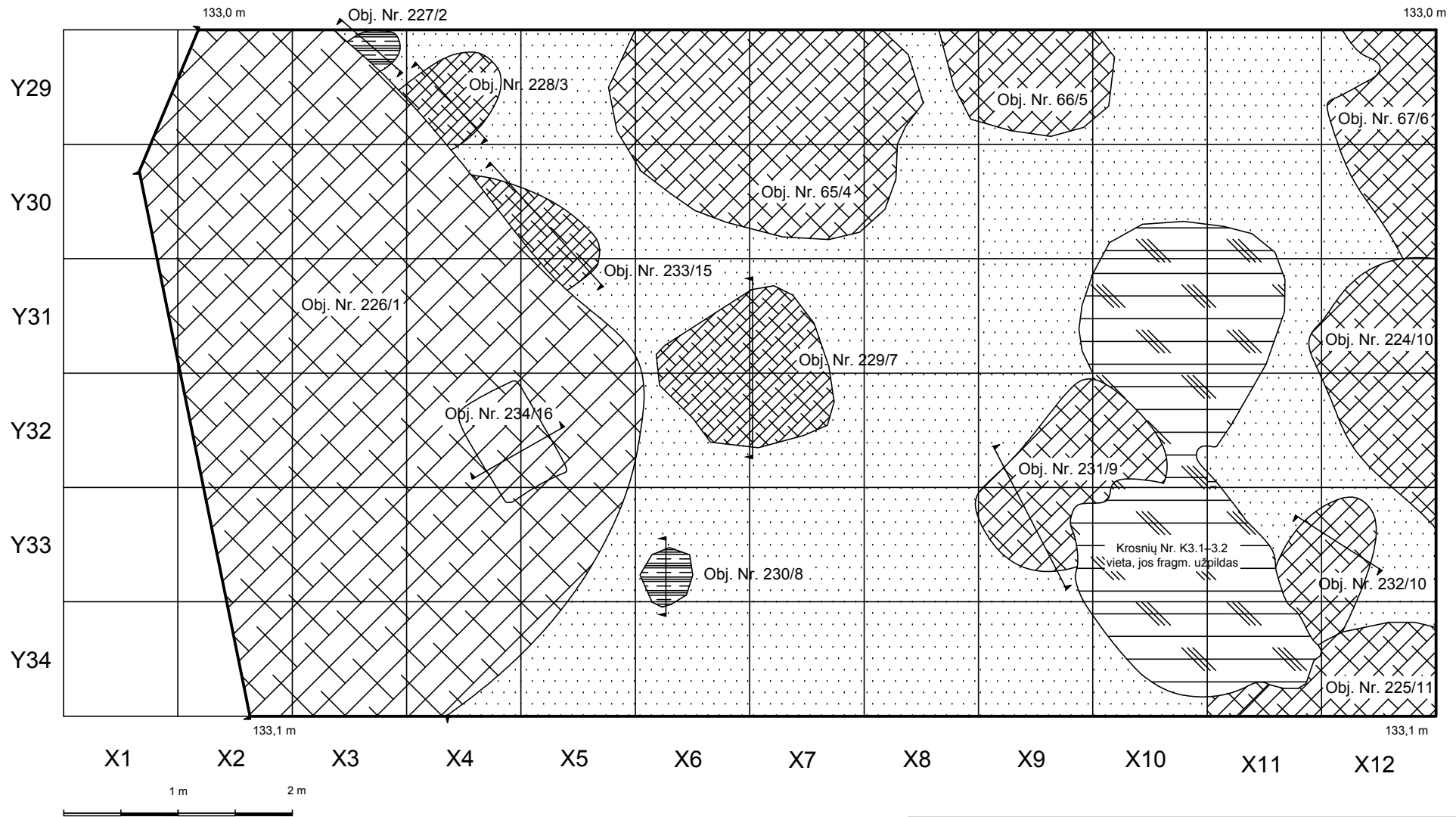

P-33 obj. sit. planas įžemyje (0,3–0,4 m gylis)

M1:50

Brėžinys Nr. 135

Obj. Nr. 227/2

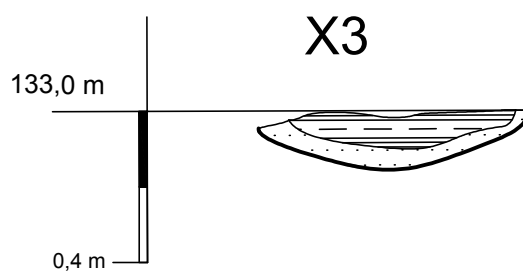

Obj. Nr. 228/3

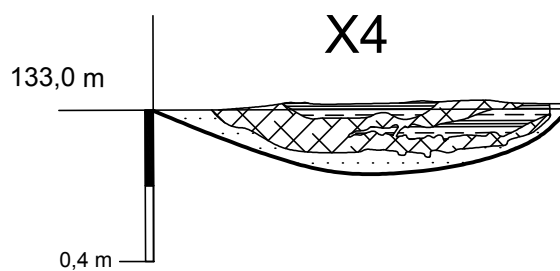

Obj. Nr. 229/7

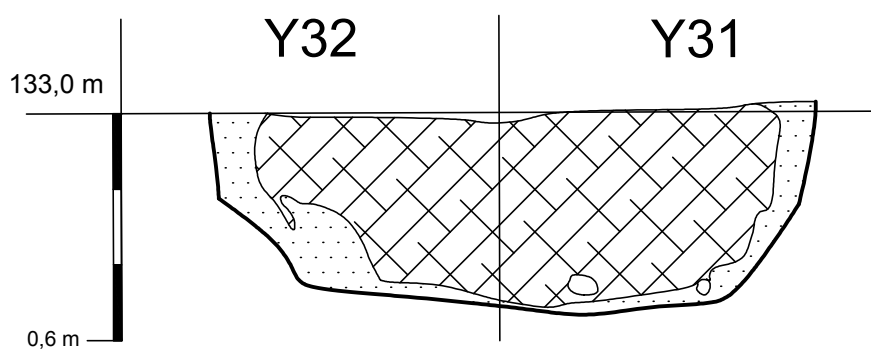

Obj. Nr. 230/8

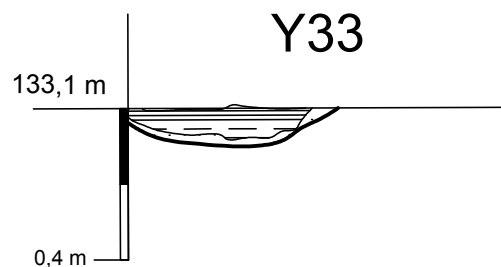

Obj. Nr. 231/9

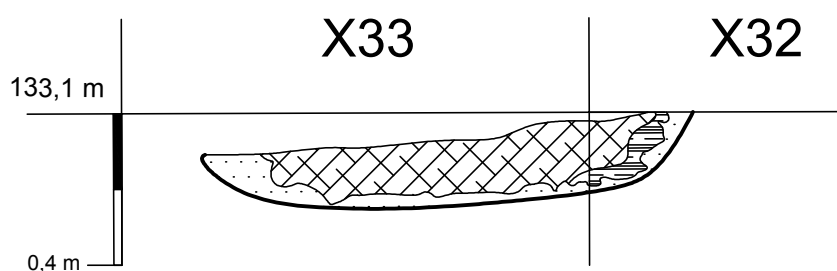

Obj. Nr. 227/2–228/3, 229/7–231/9

M1:20

Brėžinys Nr. 136

Obj. Nr. 233/15

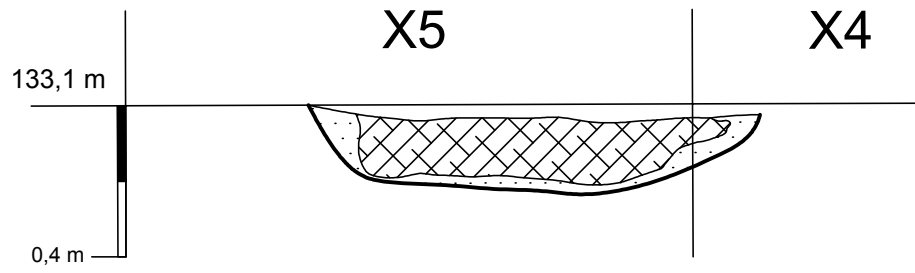

Obj. Nr. 234/16

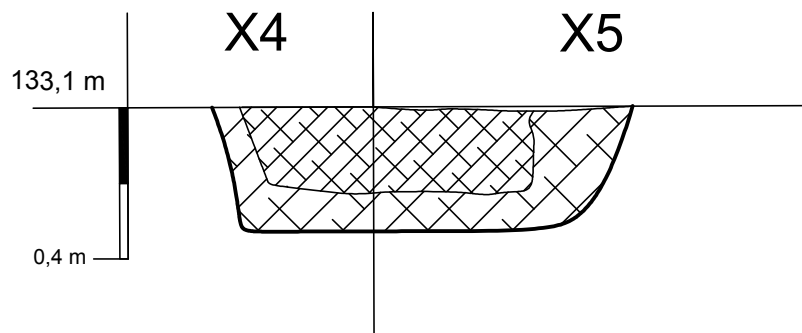

Obj. Nr. 233/15–234/16

M1:20

Brėžinys Nr. 137

P-33 P sienos pjūvis (Kv. X10-X2)

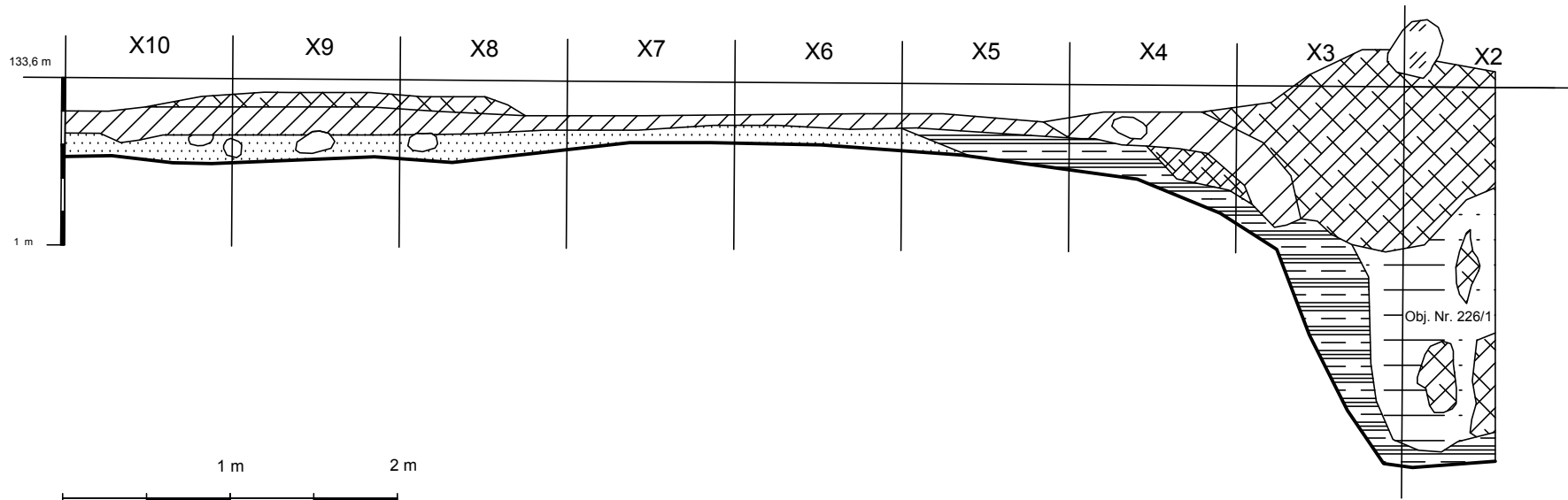

P-33 P sienos pjūvis (Kv. X10-X2)

M1:40

Brēžinys Nr. 138

P- 33 V sienos (Obj. Nr. 226/1) pjūvis

P- 15 (Kv. Y28)

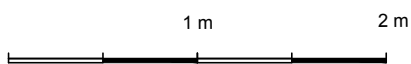
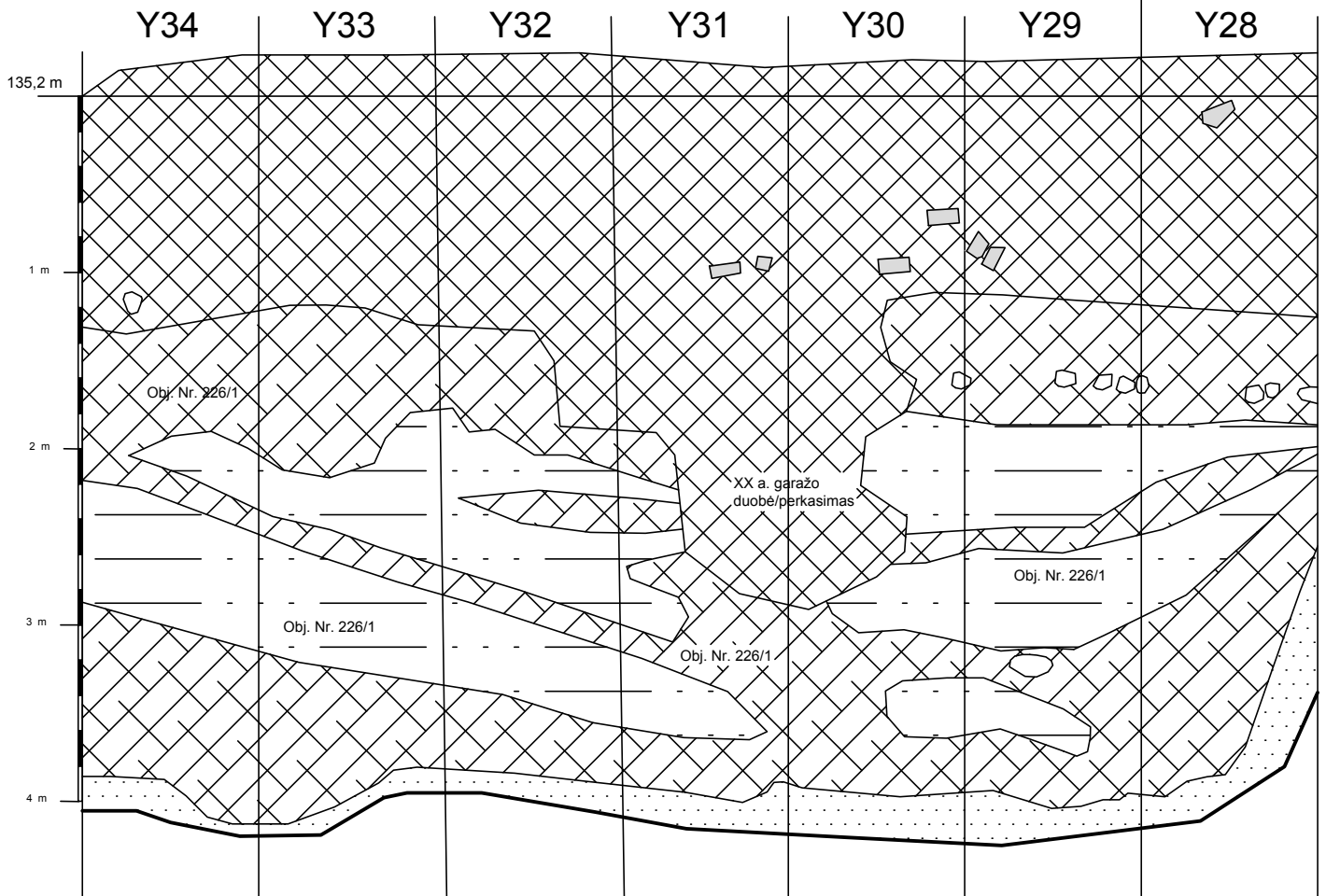

P-33 V sienos (Obj. Nr. 226/1) pjūvis

M1:40

Brėžinys Nr. 139



Krosnis Nr. K3.1

Krosnis Nr. K3.2

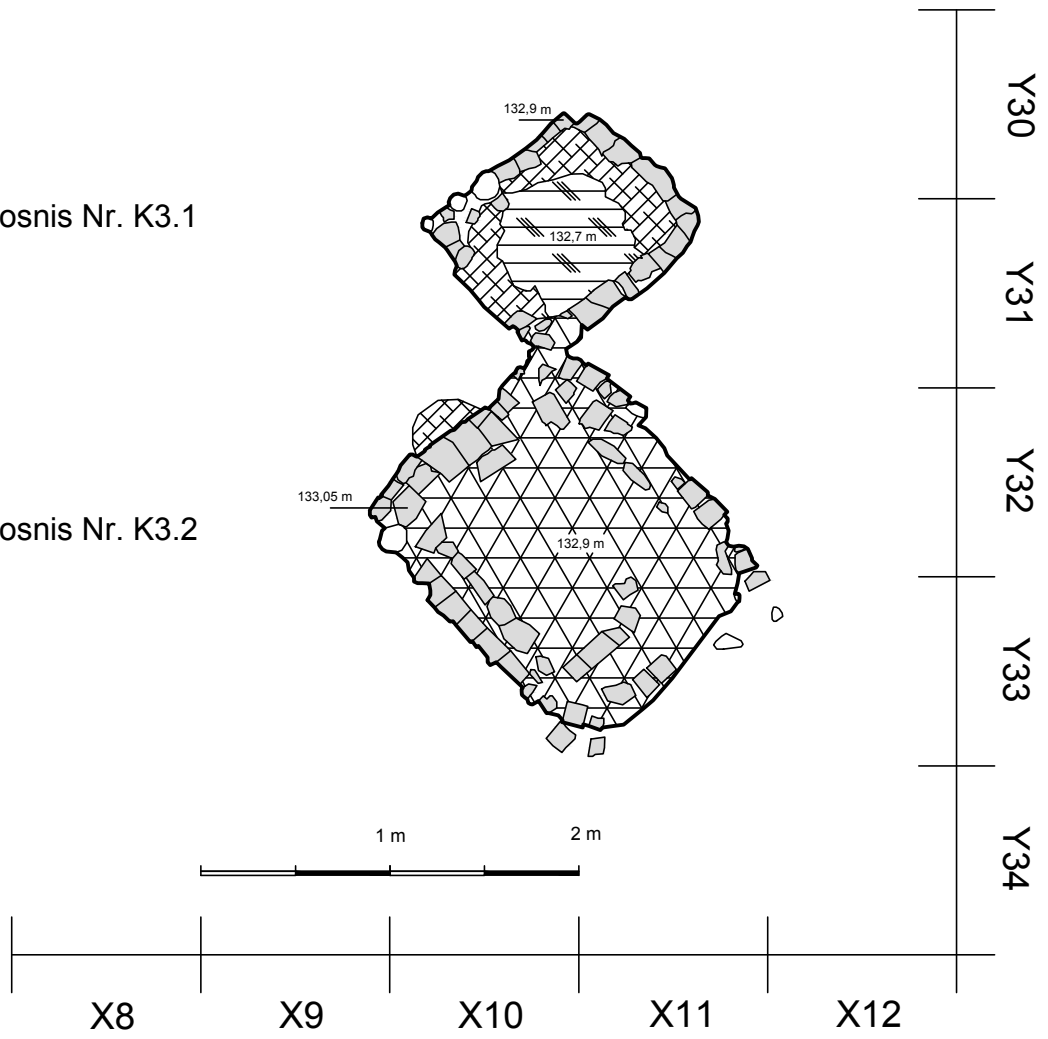

Krosnių Nr. K3.1–K3.2 planas

M1:40

Brėžinys Nr. 140



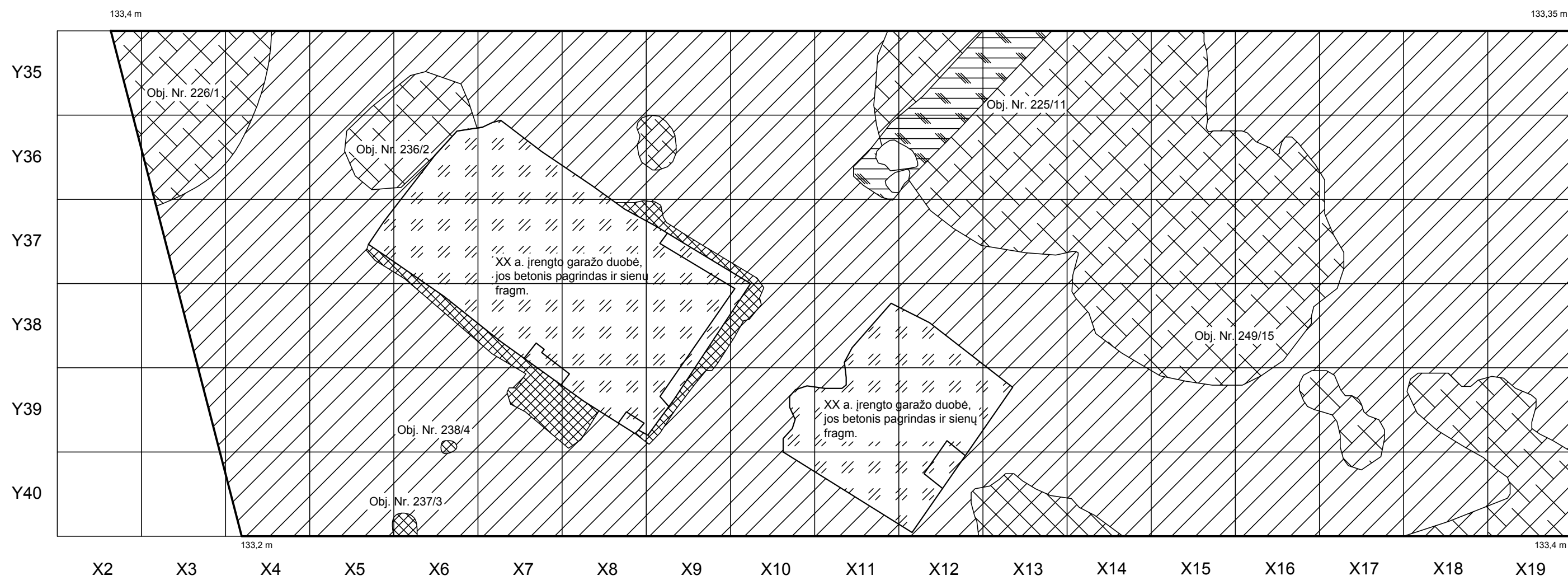

P-34 t. p. ž. sluoksnio (XV a.) sit. planas (0,4–06 m gylis)

M1:50

Brėžinys Nr. 141

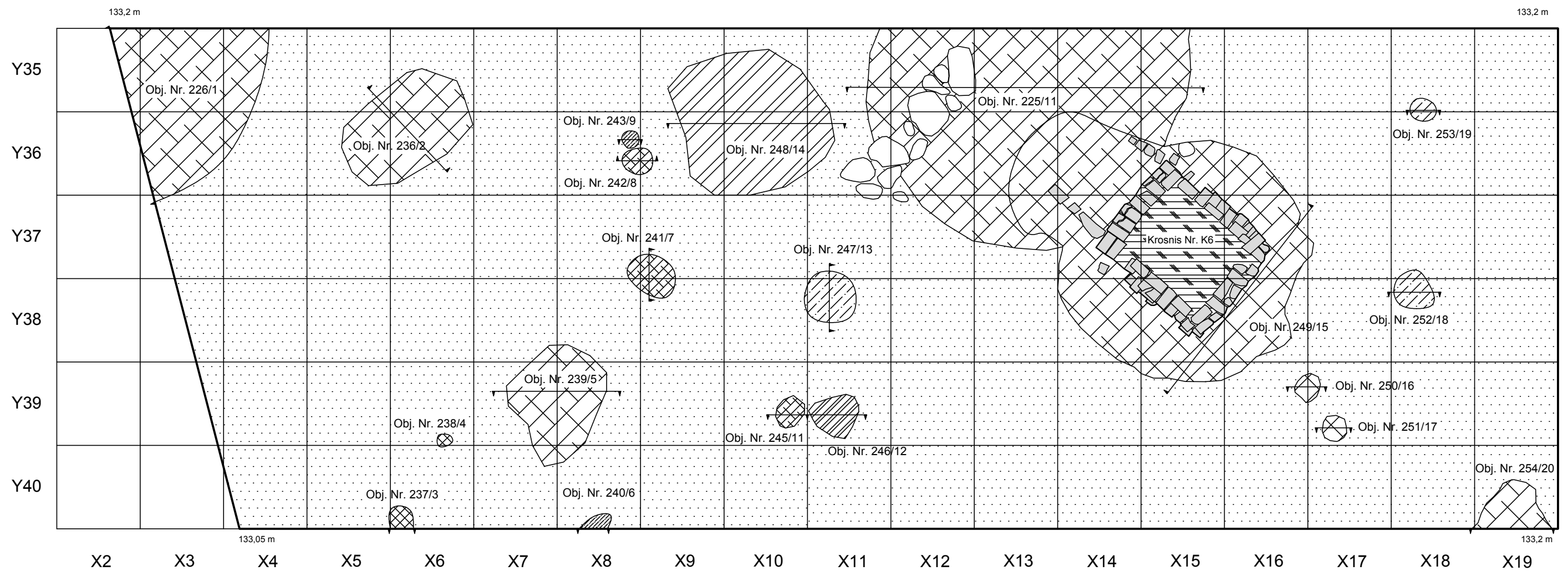

P-34 obj. sit. planas įžemyje (0,6–0,8 m gylis)

M1:50

Brėžinys Nr. 142

# Obj. Nr. 236/2

X5

X6

133,1 m

1 m

2 m

0,2 m

1 m

Obj. Nr. 236/2

M1:20

Brėžinys Nr. 143

Obj. Nr. 239/5

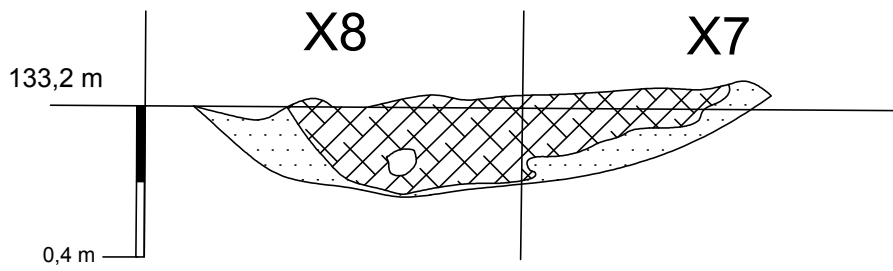

Obj. Nr. 242/8

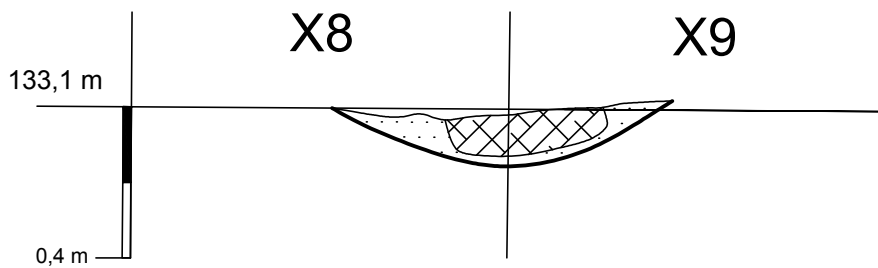

Obj. Nr. 244/10

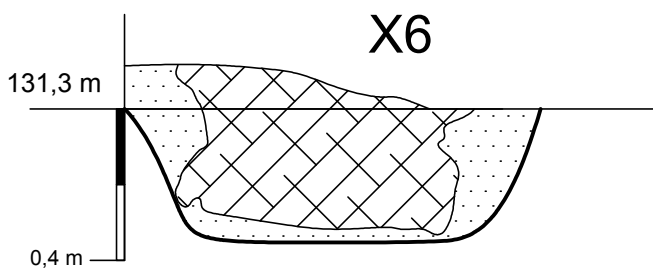

Obj. Nr. 245/11

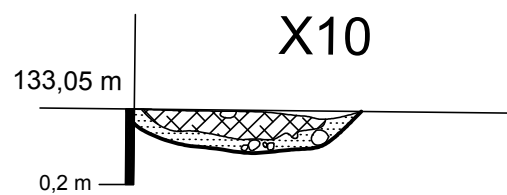

Obj. Nr. 246/12

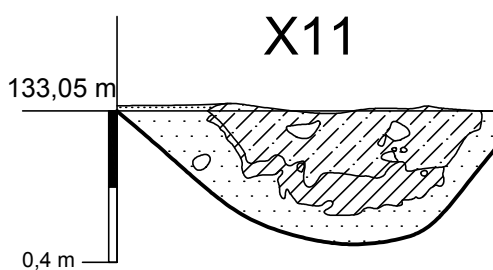

Obj. Nr. 247/13

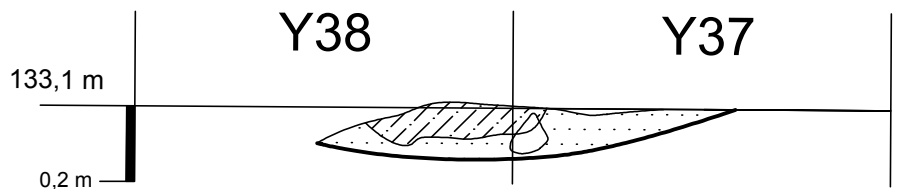

Obj. Nr. 239/5, 242/8, 244/10–247/13

M1:20

Brėžinys Nr. 144

# Obj. Nr. 249/15

Krosnis Nr. K6 PR siena

X15

X16

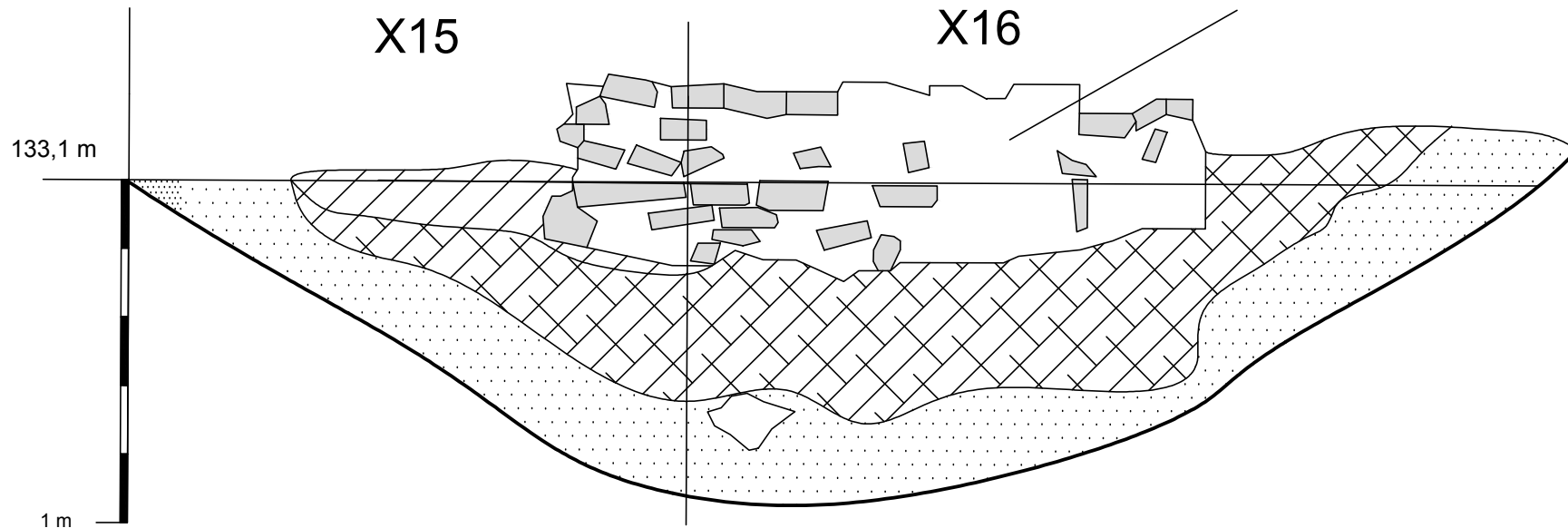

# Obj. Nr. 248/14

X11

X10

X9

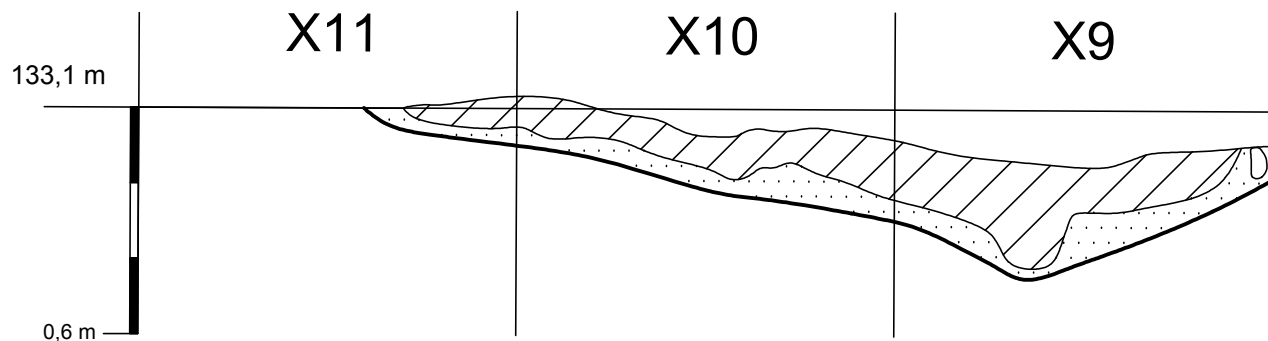

Obj. Nr. 248/14–249/15

M1:20

Brėžinys Nr. 145

Obj. Nr. 250/16

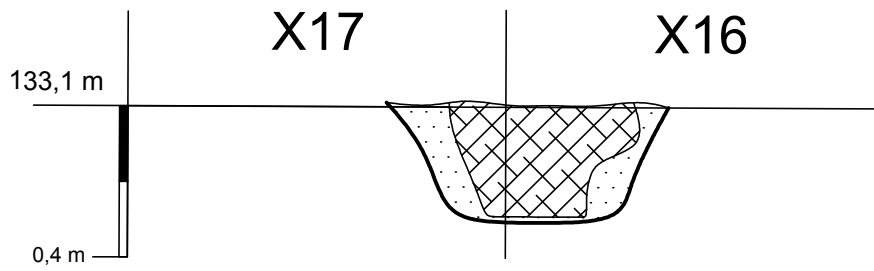

Obj. Nr. 251/17

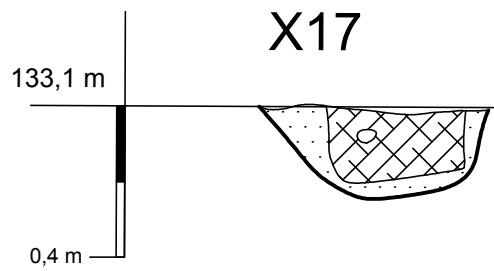

Obj. Nr. 252/18

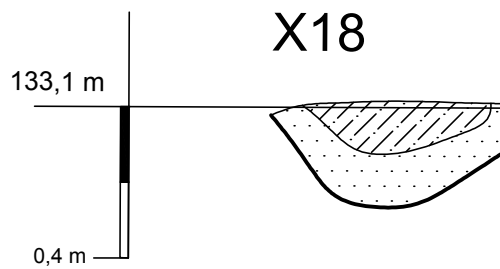

Obj. Nr. 250/16–252/18

M1:20

Brėžinys Nr. 146

P-34 P sienos pjūvis

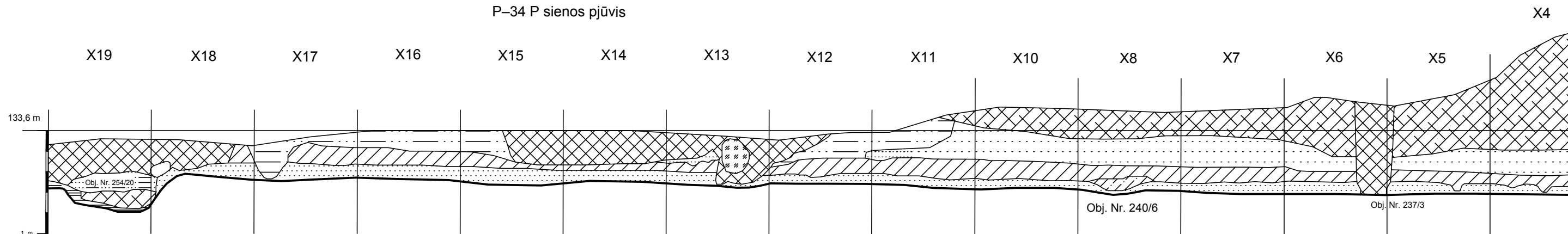

P-34 PV sienos pjūvis

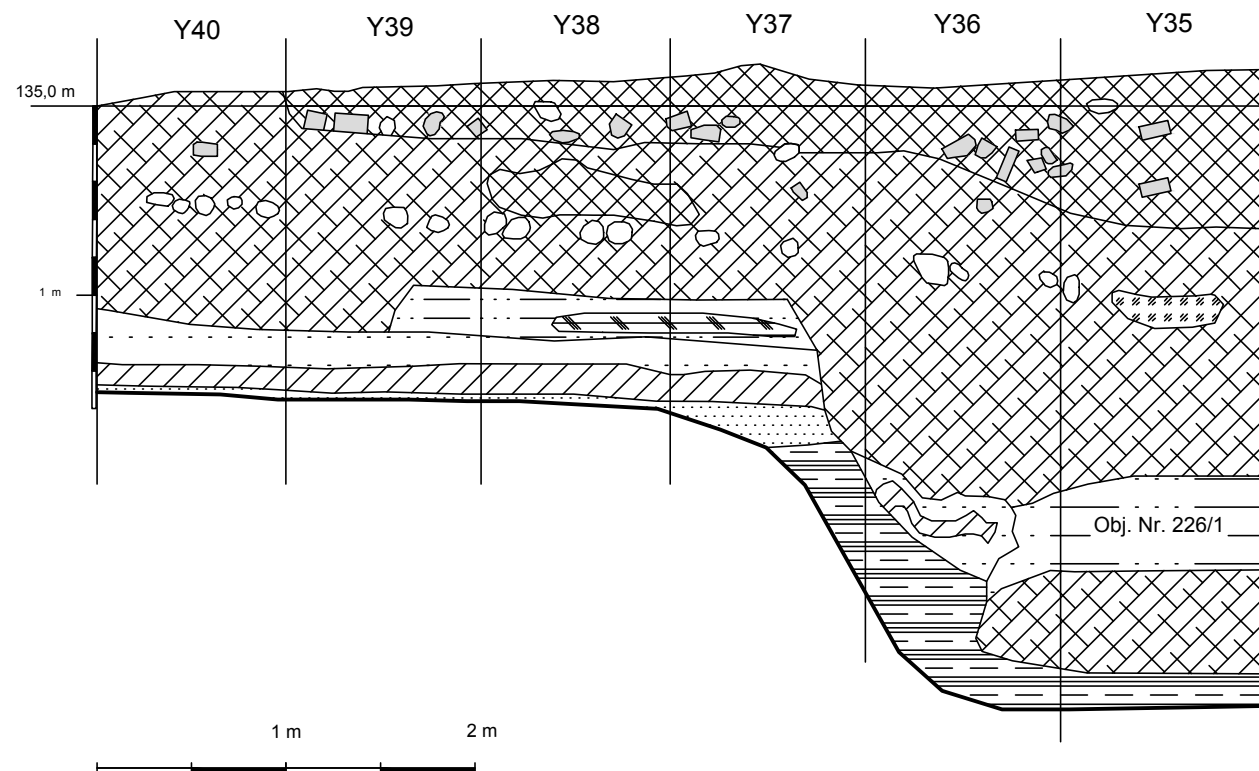

P-34 P, PV sienų pjūviai

M1:40

Brėžinys Nr. 147

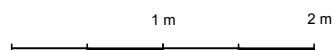
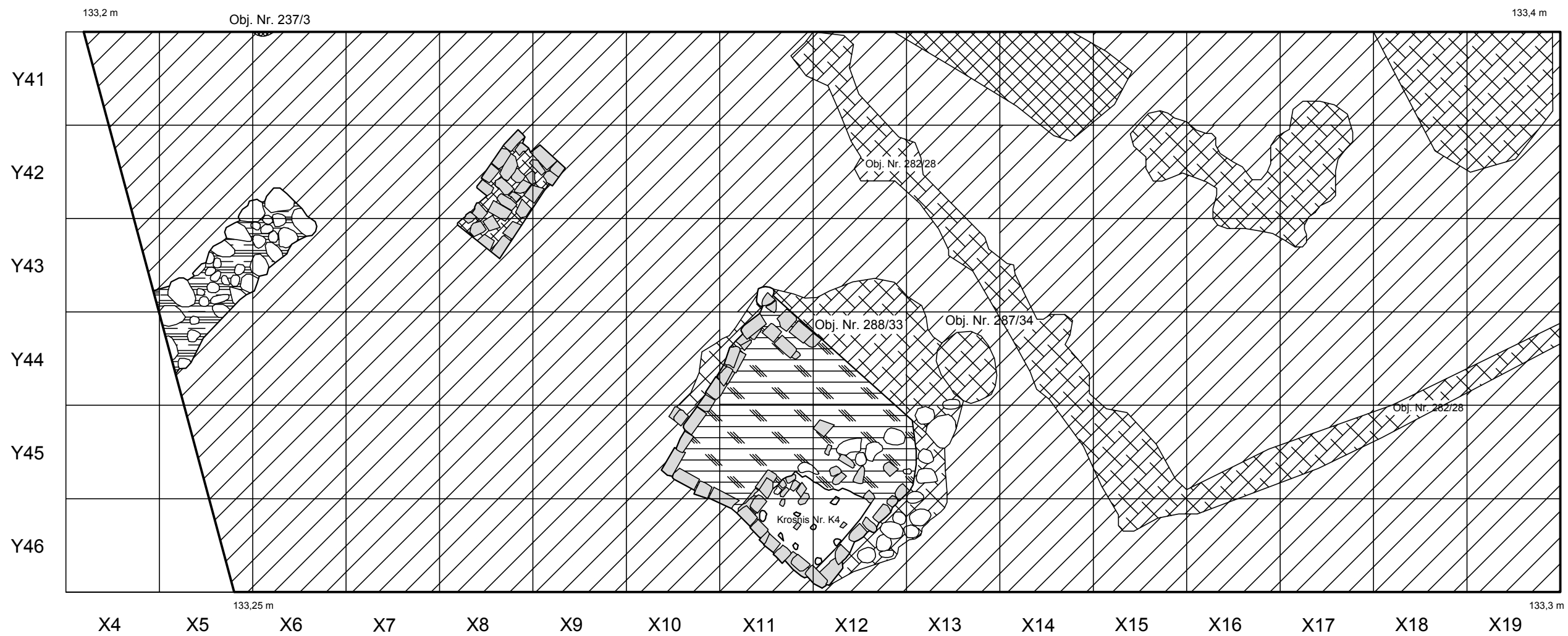

P-35 t. p. ž. sluoksniu (XV a.) sit. planas (0,5 m gylio)
M1:50
Brėžinys Nr. 148



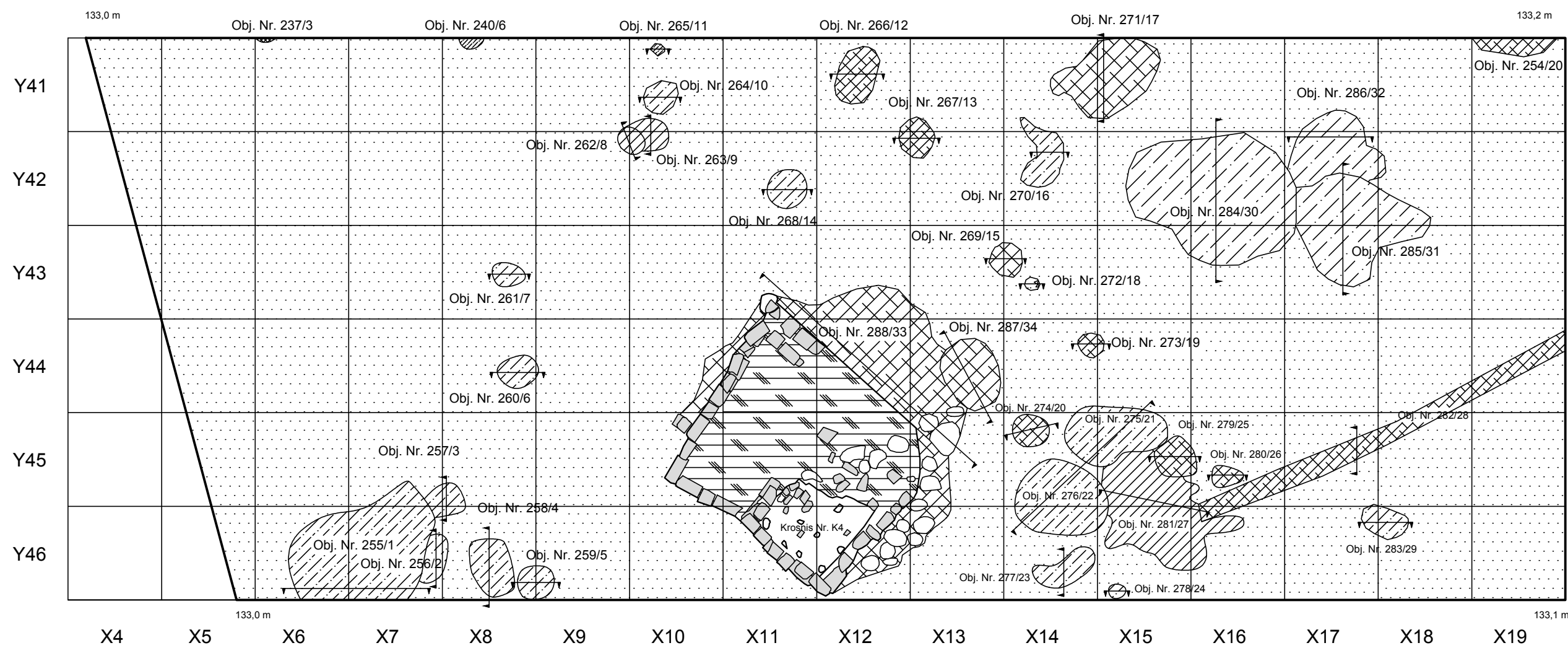

P-35 obj. sit. planas įžemyje (0,7 m gylis)

M1:50

Brėžinys Nr. 149

Obj. Nr. 258/4

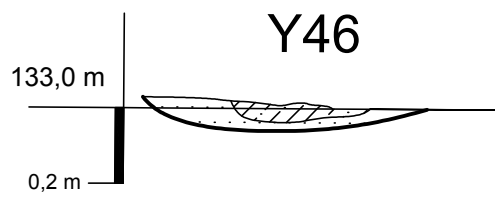

Obj. Nr. 259/5

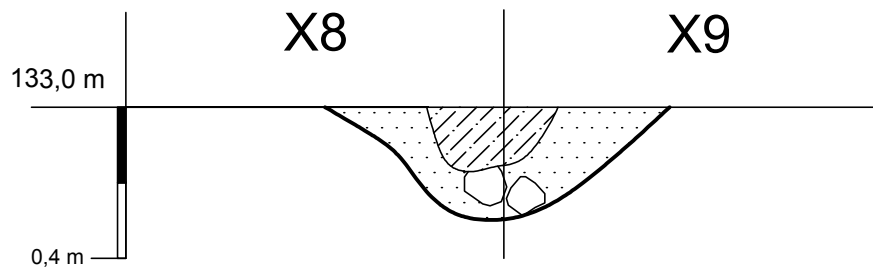

Obj. Nr. 260/6

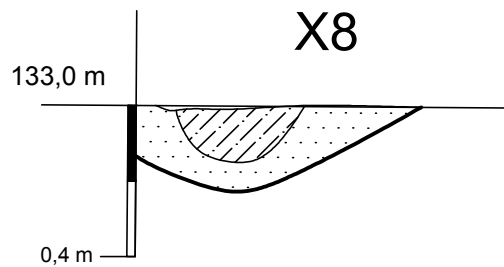

Obj. Nr. 262/8

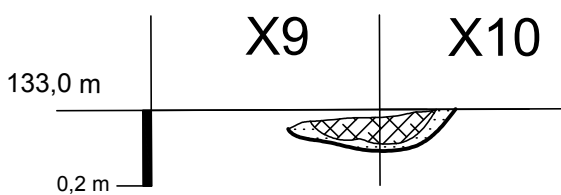

Obj. Nr. 258/4–260/6, 262/8

M1:20

Brėžinys Nr. 150

Obj. Nr. 263/9

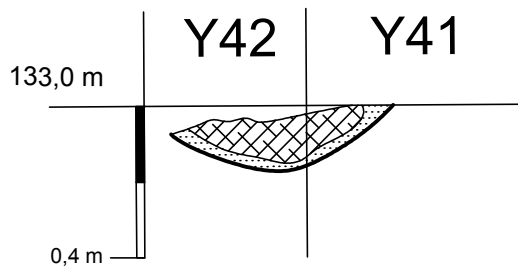

Obj. Nr. 264/10

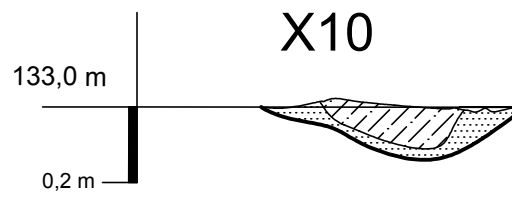

Obj. Nr. 265/11

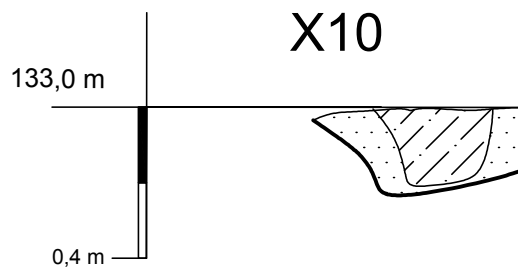

Obj. Nr. 266/12

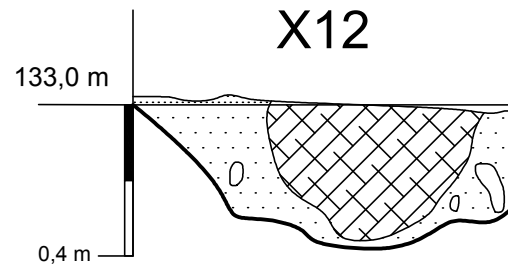

Obj. Nr. 267/13

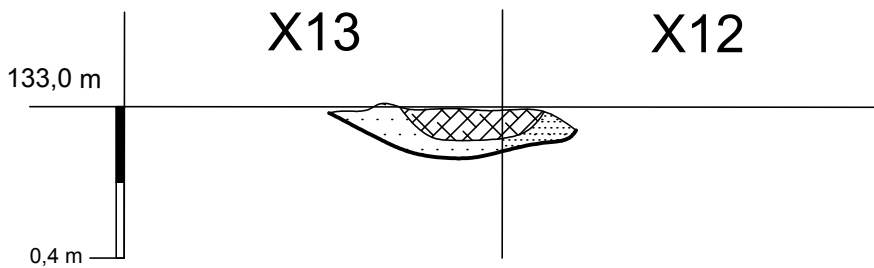

Obj. Nr. 269/15

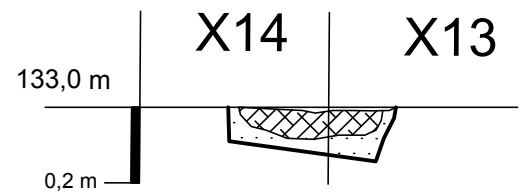

Obj. Nr. 270/16

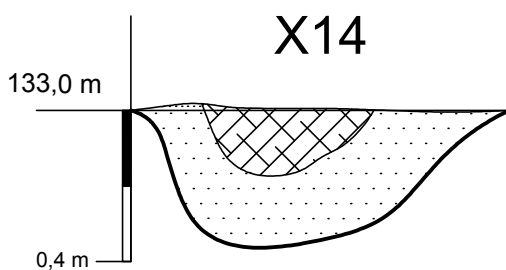

Obj. Nr. 271/17

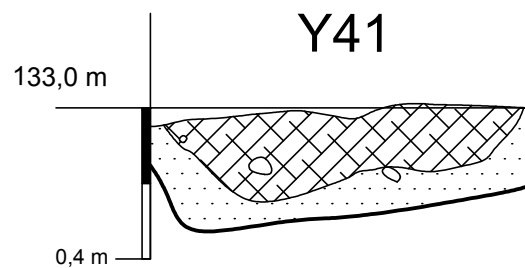

Obj. Nr. 263/9–267/13, 269/15–271/17

M1:20

Brėžinys Nr. 151

Obj. Nr. 273/19

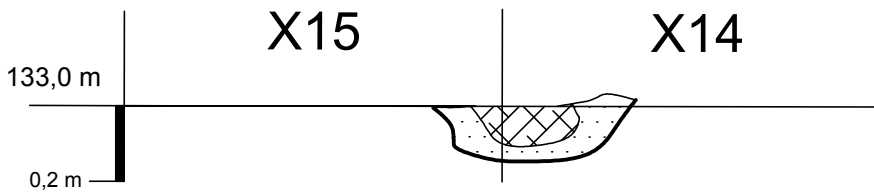

Obj. Nr. 274/20

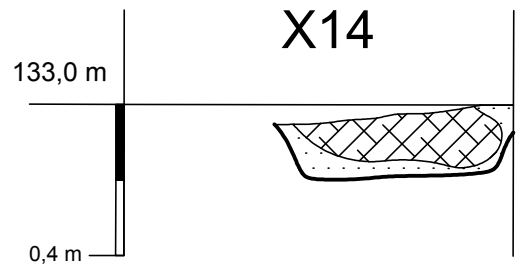

Obj. Nr. 279/25

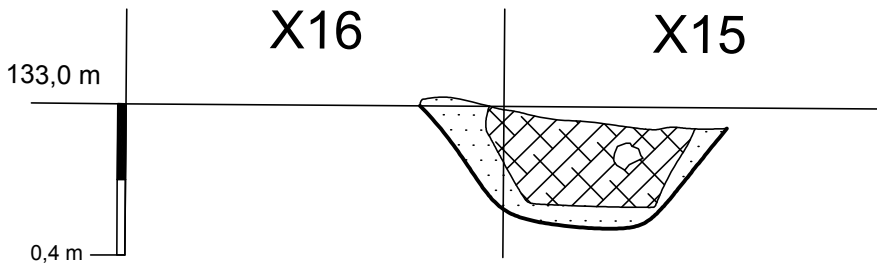

Obj. Nr. 280/26

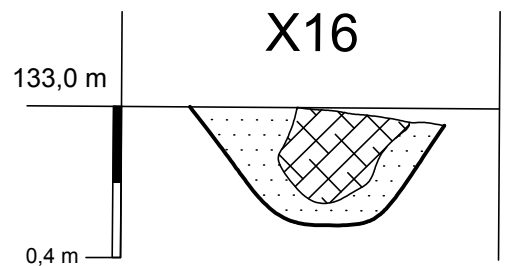

Obj. Nr. 281/27

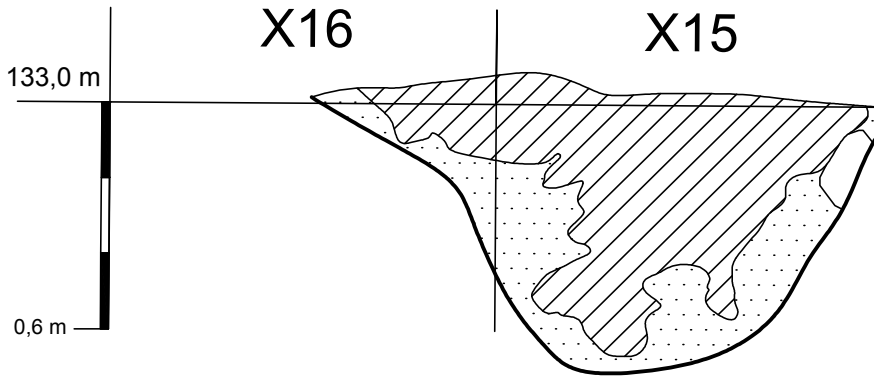

Obj. Nr. 282/28

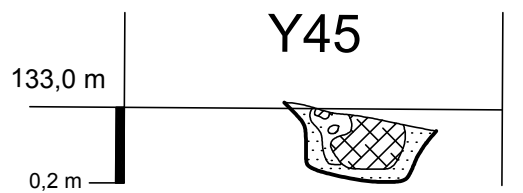

Obj. Nr. 283/29

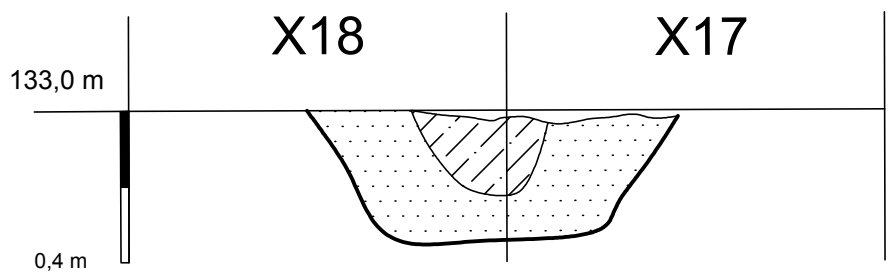

Obj. Nr. 273/19–274/20, 279/25–/283/29

M1:20

Brėžinys Nr. 152

Obj. Nr. 285/31

Obj. Nr. 286/32

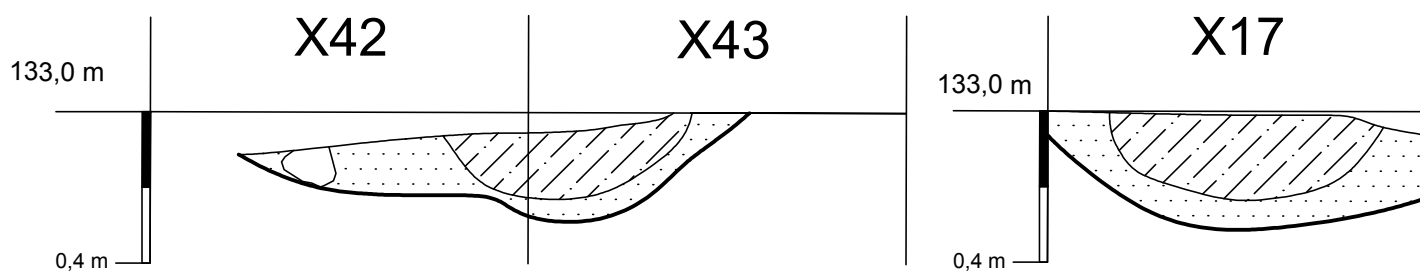

Obj. Nr. 287/33

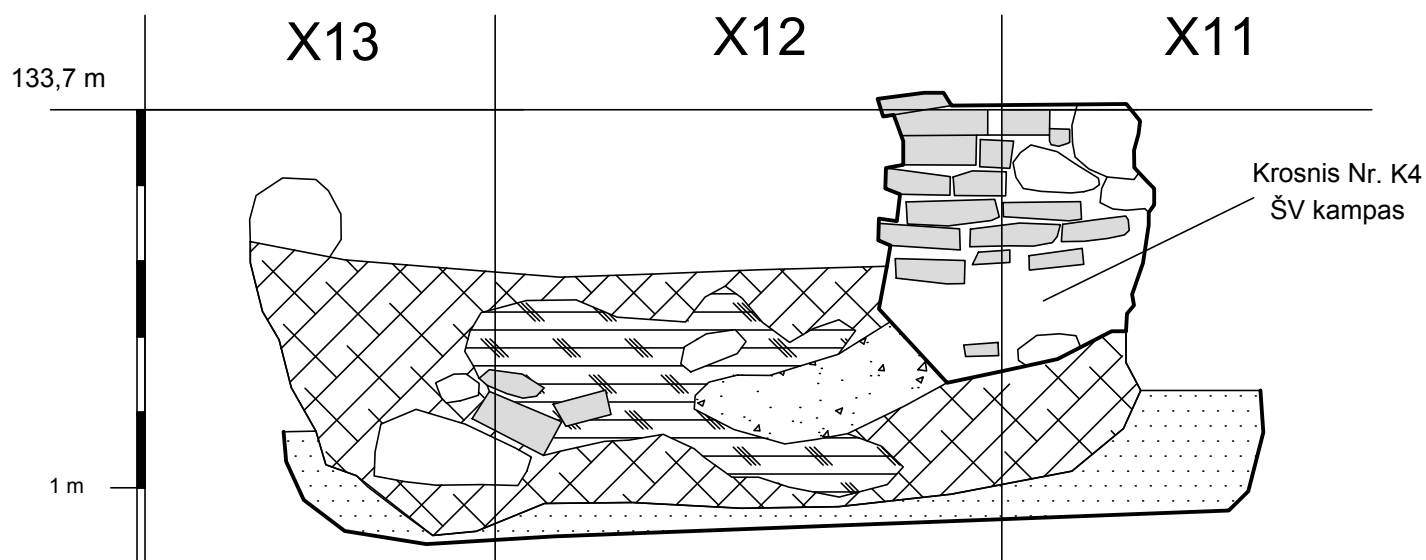

Obj. Nr. 288/34

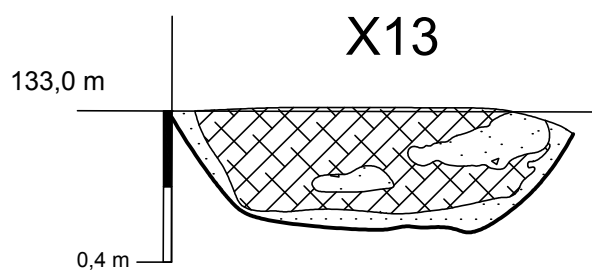

Obj. Nr. 285/31–288/34

M1:20

Brėžinys Nr. 153

P-35 P sienos pjūvis

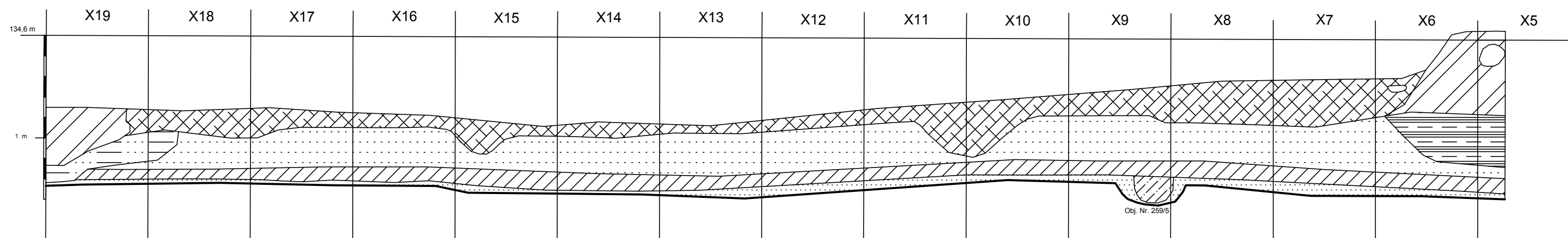

P-35 PV sienos pjūvis

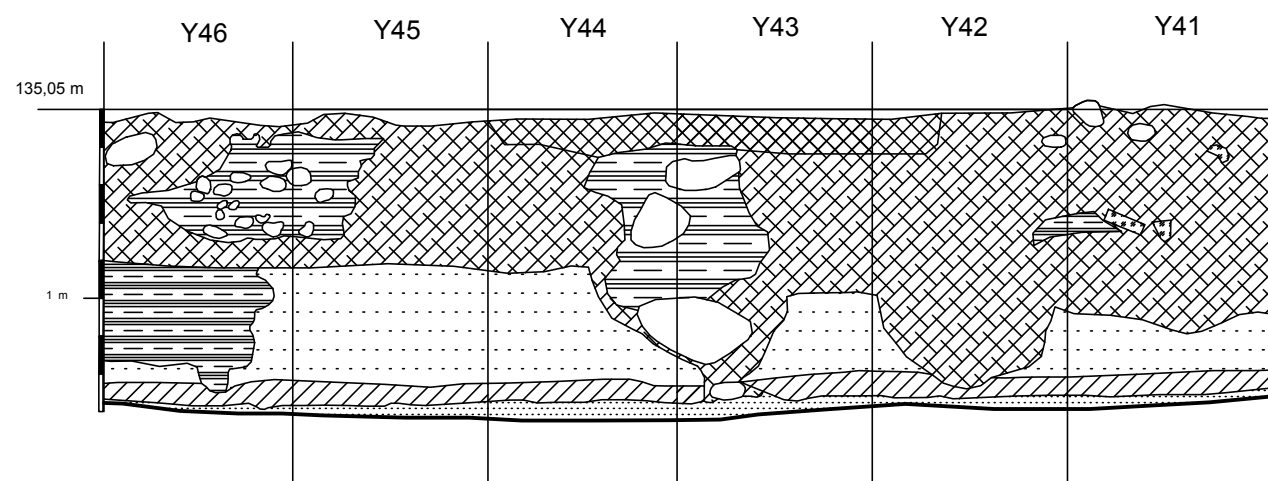

P-35 R sienos pjūvis (Kv. Y43-Y46)

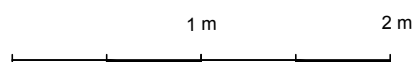
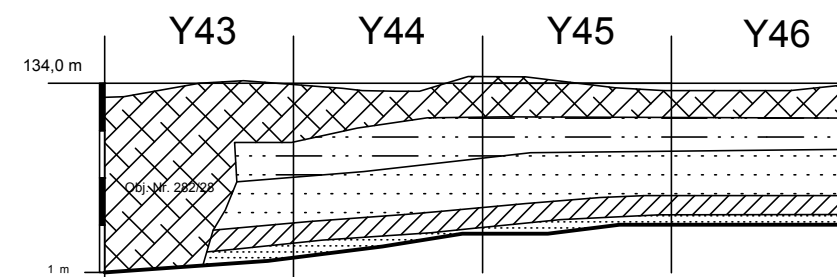

P-35 R sienos pjūvis (Kv. Y43-Y46);  
P-35 P, PV sienų pjūviai

M1:40

Brėžinys Nr. 154

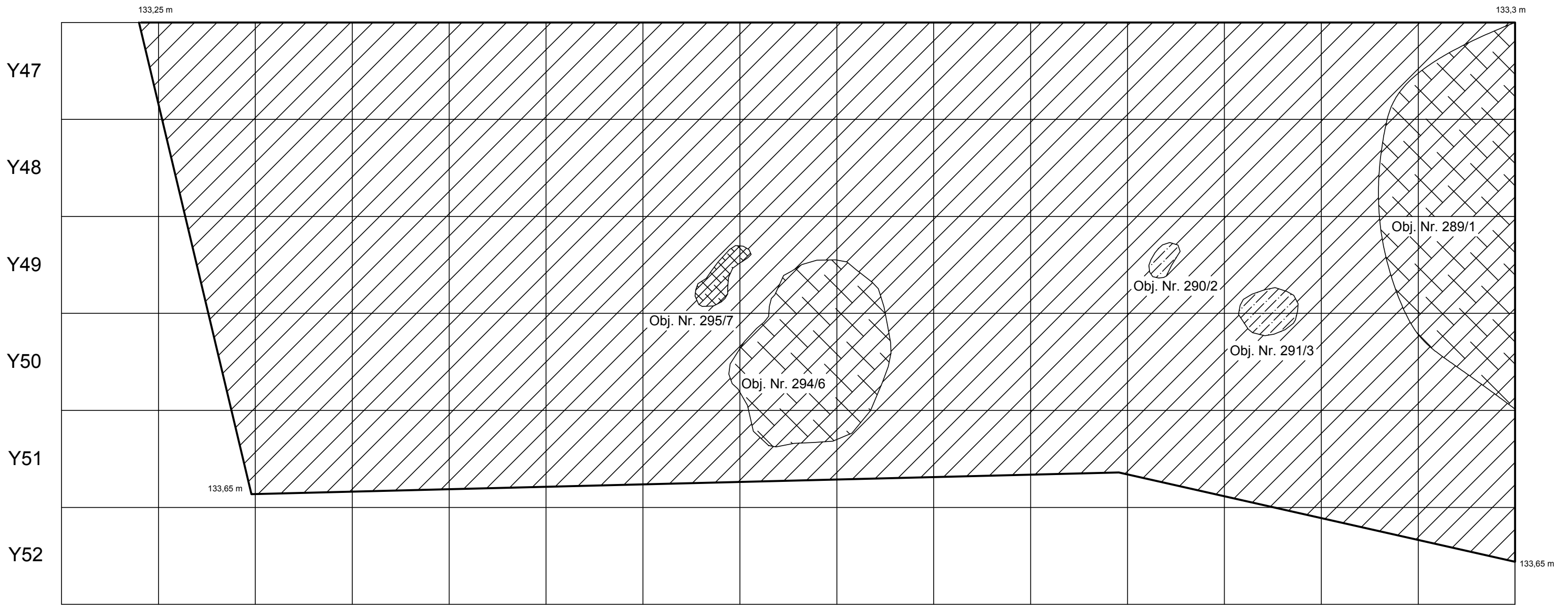

Y47  
Y48  
Y49  
Y50  
Y51  
Y52

X5 X6 X7 X8 X9 X10 X11 X12 X13 X14 X15 X16 X17 X18 X19

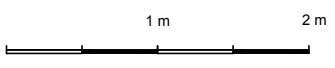

P-36 t. p. ž. sluoksniu (XV a.) sit. planas (0,5 m gylis)	
M1:50	
Brėžinys Nr. 155	166

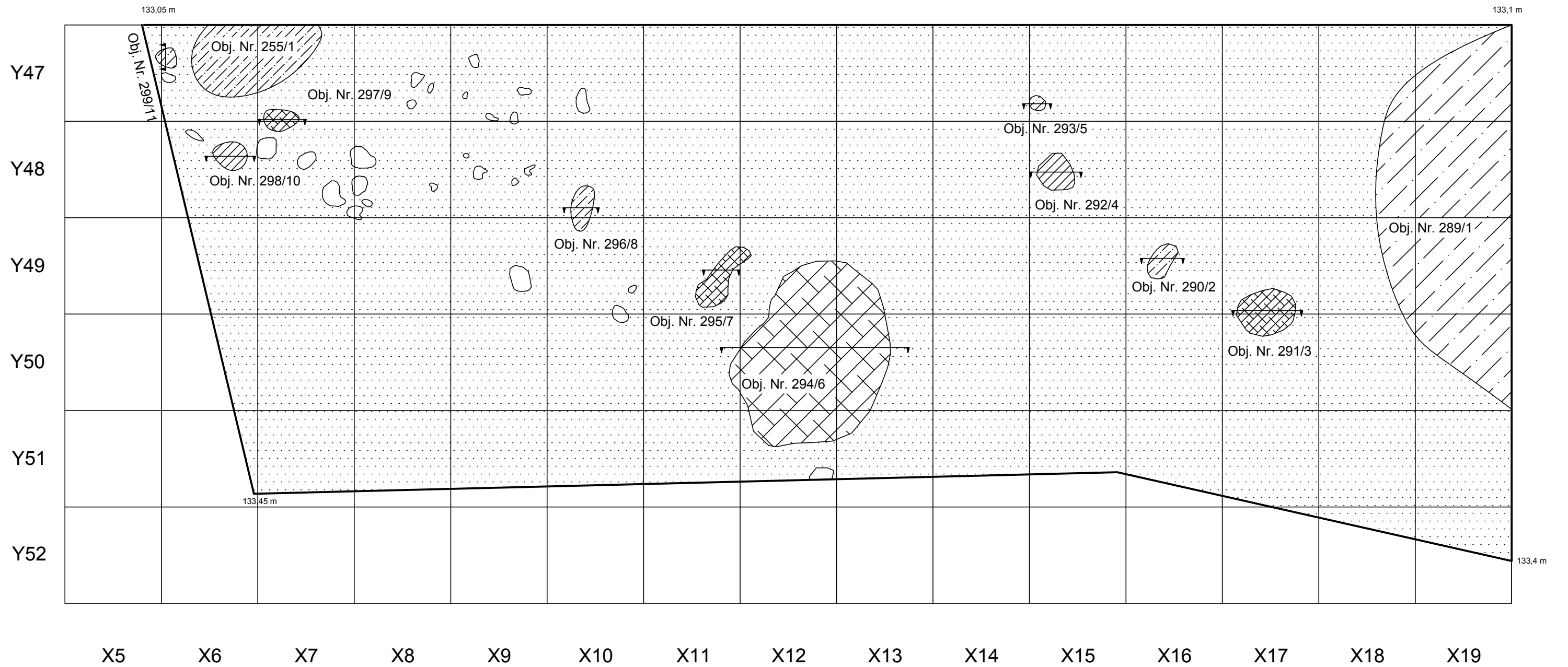

P-36 obj. sit. planas įžemyje (0,6–0,7 m gylis)
M1:50
Brėžinys Nr. 156



Obj. Nr. 290/2

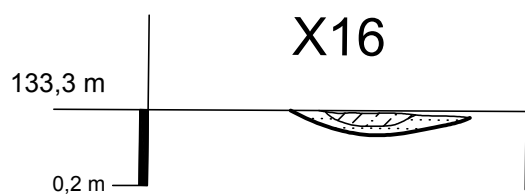

Obj. Nr. 291/3

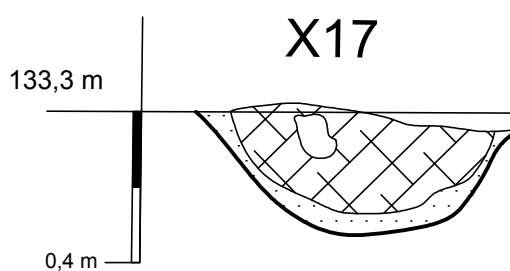

Obj. Nr. 292/4

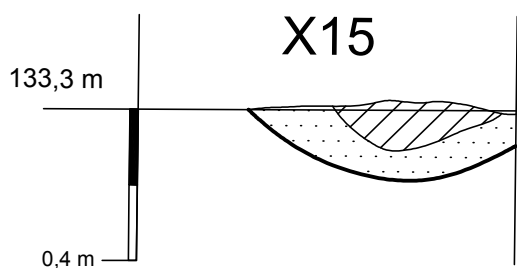

Obj. Nr. 293/5

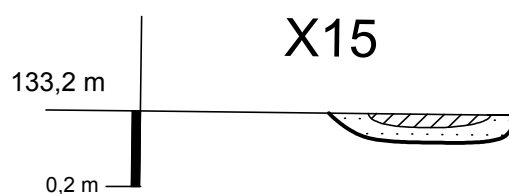

Obj. Nr. 294/6

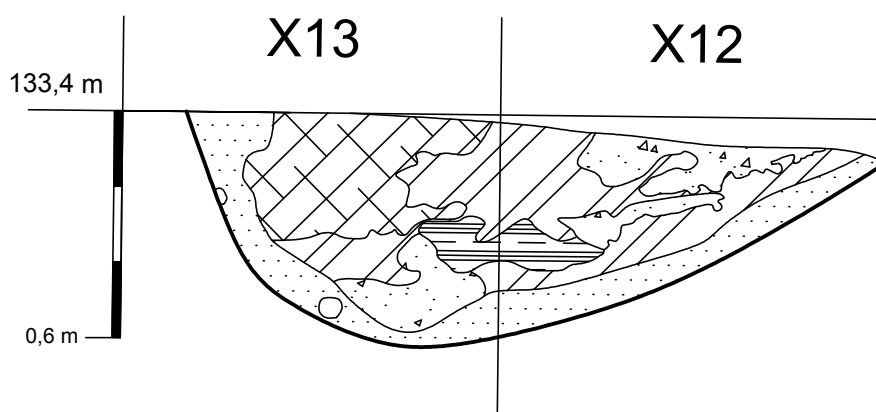

Obj. Nr. 295/7

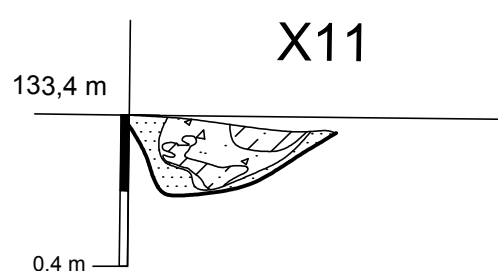

Obj. Nr. 297/9

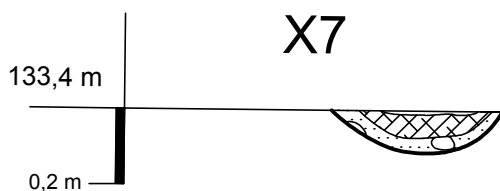

Obj. Nr. 298/10

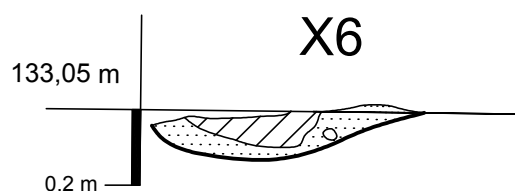

Obj. Nr. 290/2–296/7, 297/9–298/10

M1:20

Brėžinys Nr. 157



P-36 P sienos pjūvis

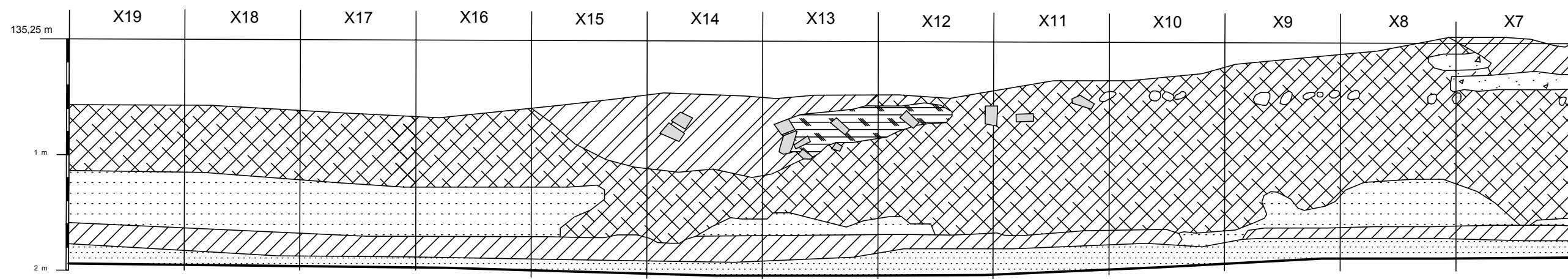

P-36 PV sienos pjūvis

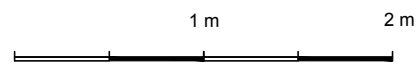
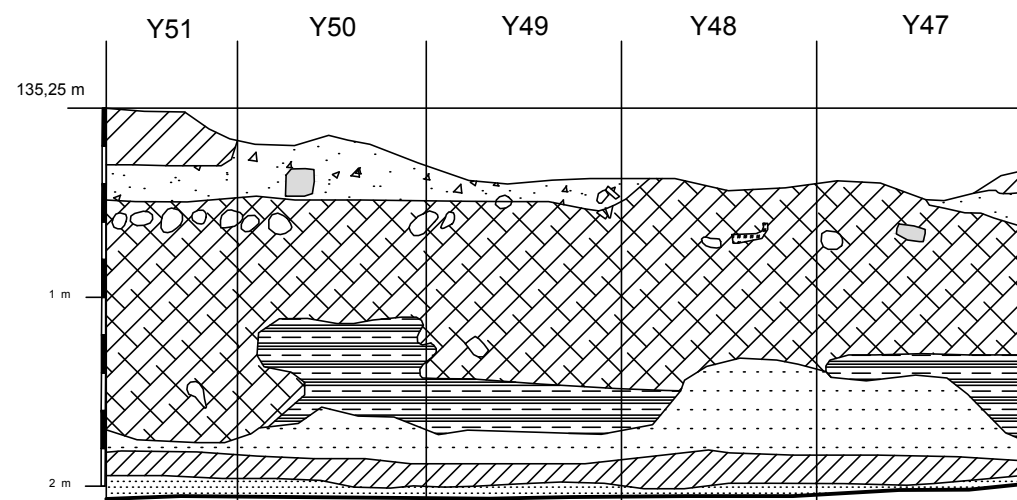

P-36 P, PV sienų pjūviai

M1:40

Brėžinys Nr. 158

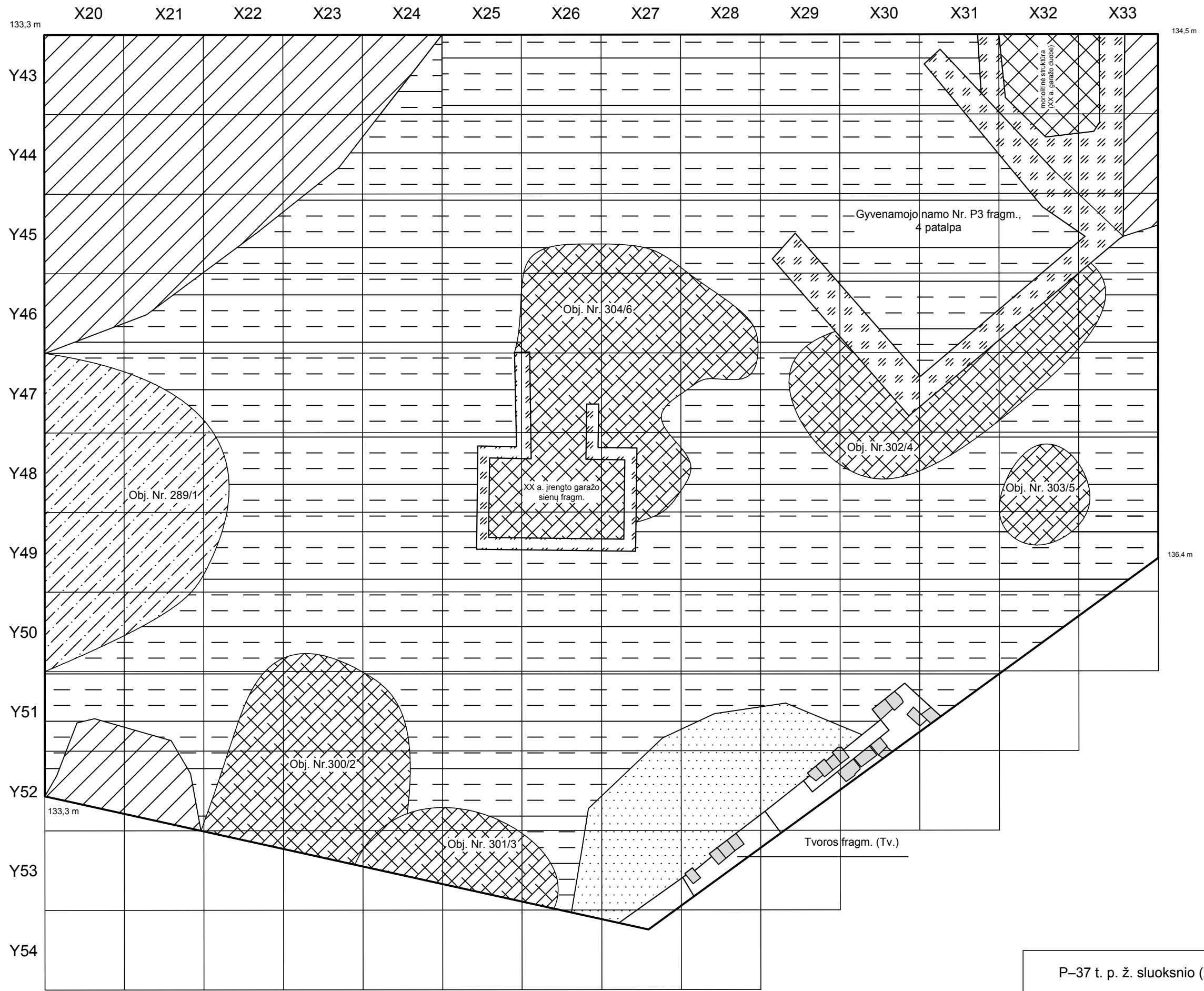

P-37 t. p. ž. sluoksniu (XV a.) sit. planas (0,45–0,5 m gylis)

M1:50

Brėžinys Nr. 159

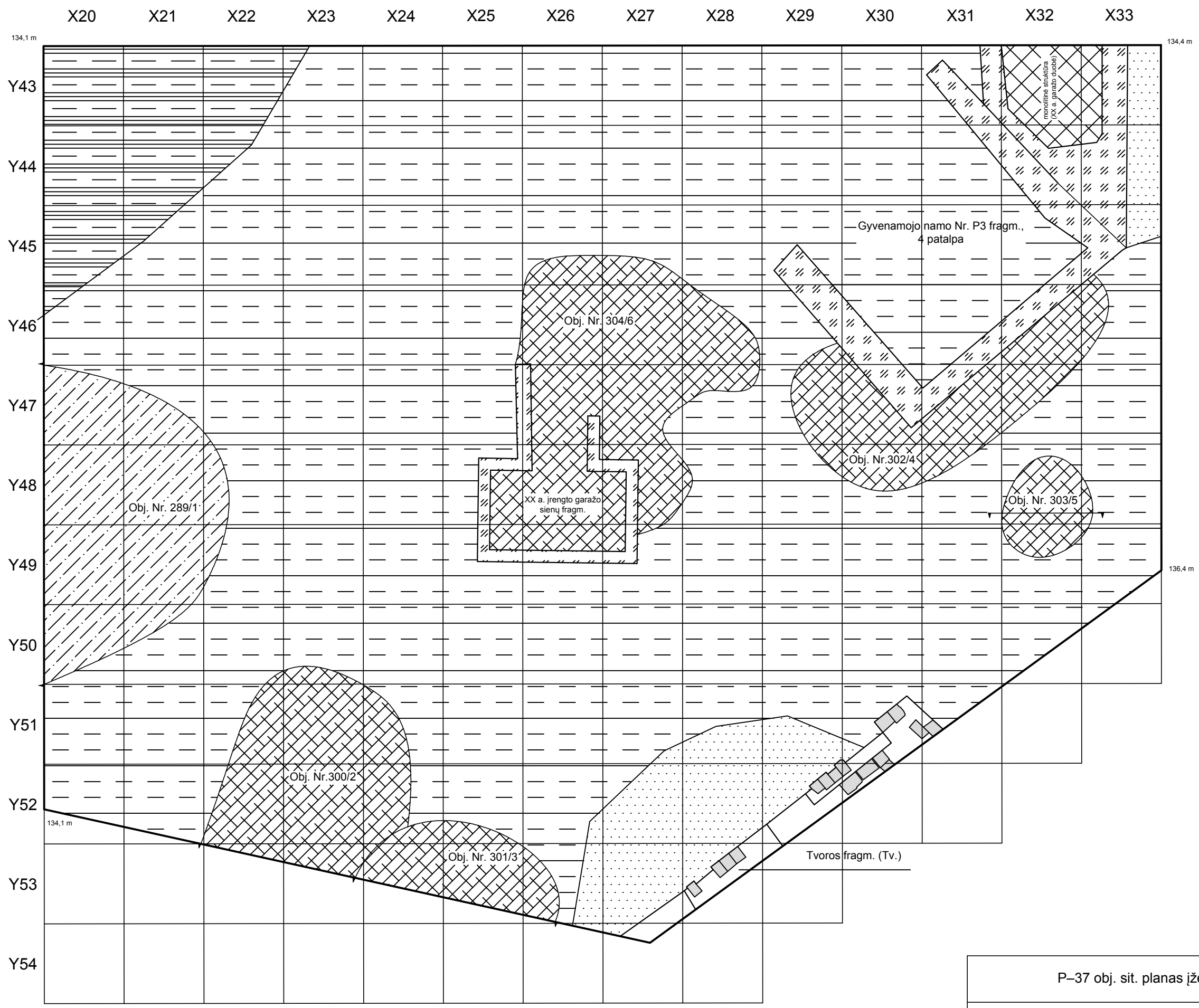

P-37 obj. sit. planas įžemyje (0,6 m gylis)

M1:50

Brėžinys Nr. 160

X26

X25

P-37 PV sienos pjūvis

Tvoros (Tv.) fragm.

X24

X23

X22

X21

X20

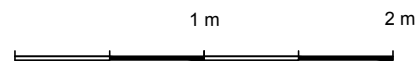
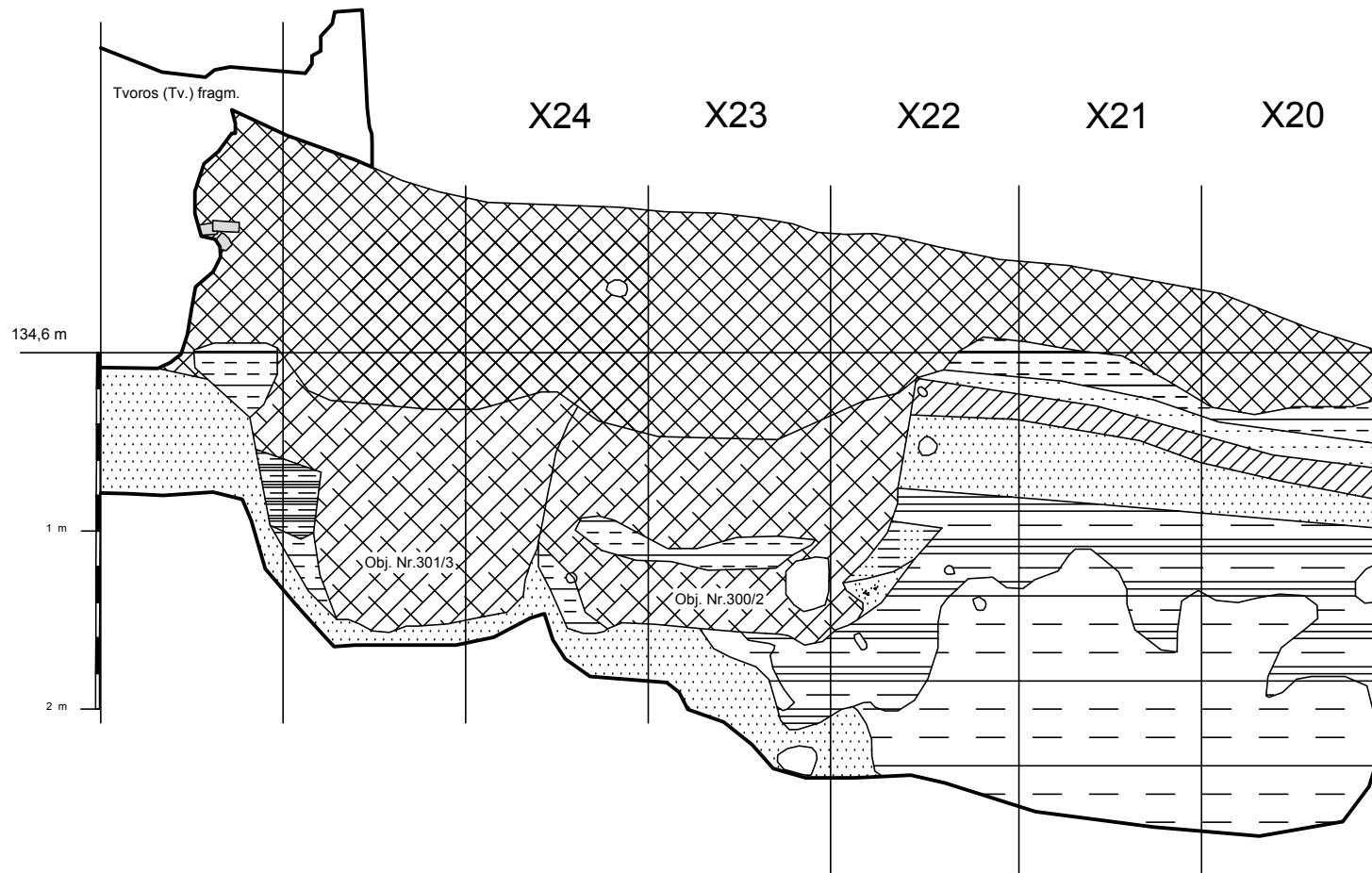

P-37 PV sienos pjūvis

M1:40

Brēžinys Nr. 161

P-37 P sienos pjūvis

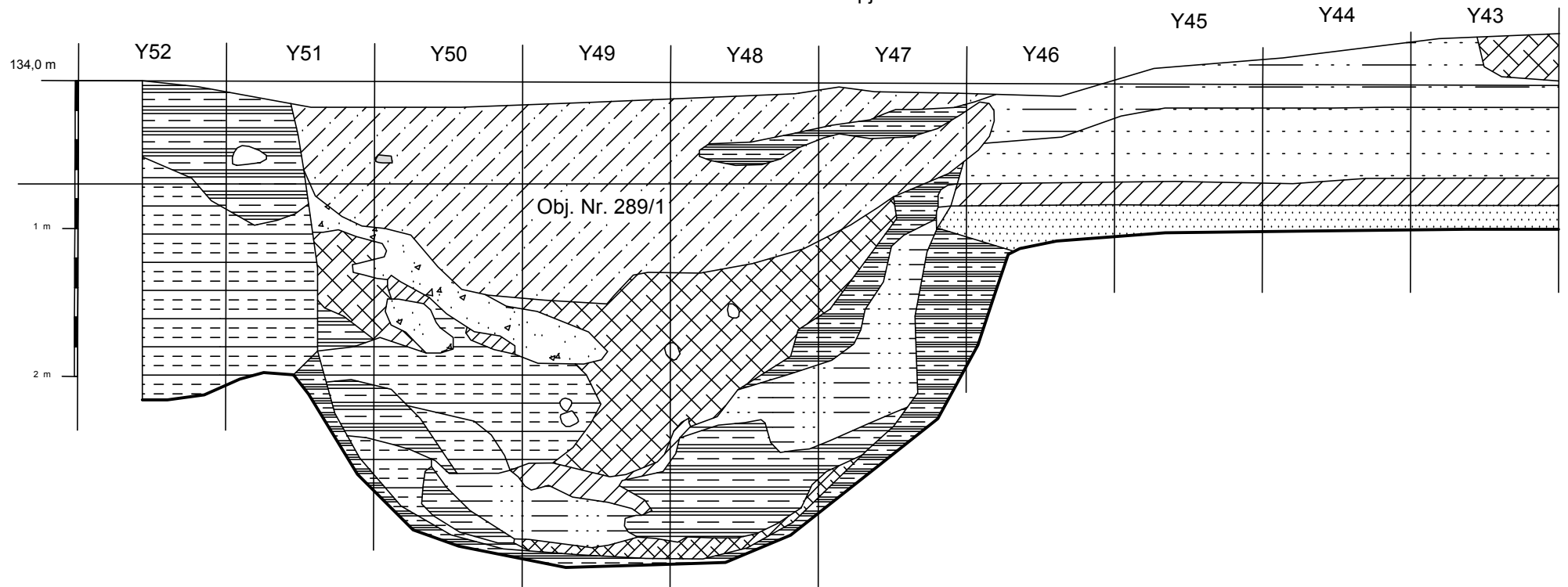

P-37 V sienos pjūvis

M1:40

Brēžinys Nr. 162

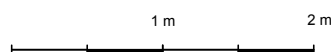
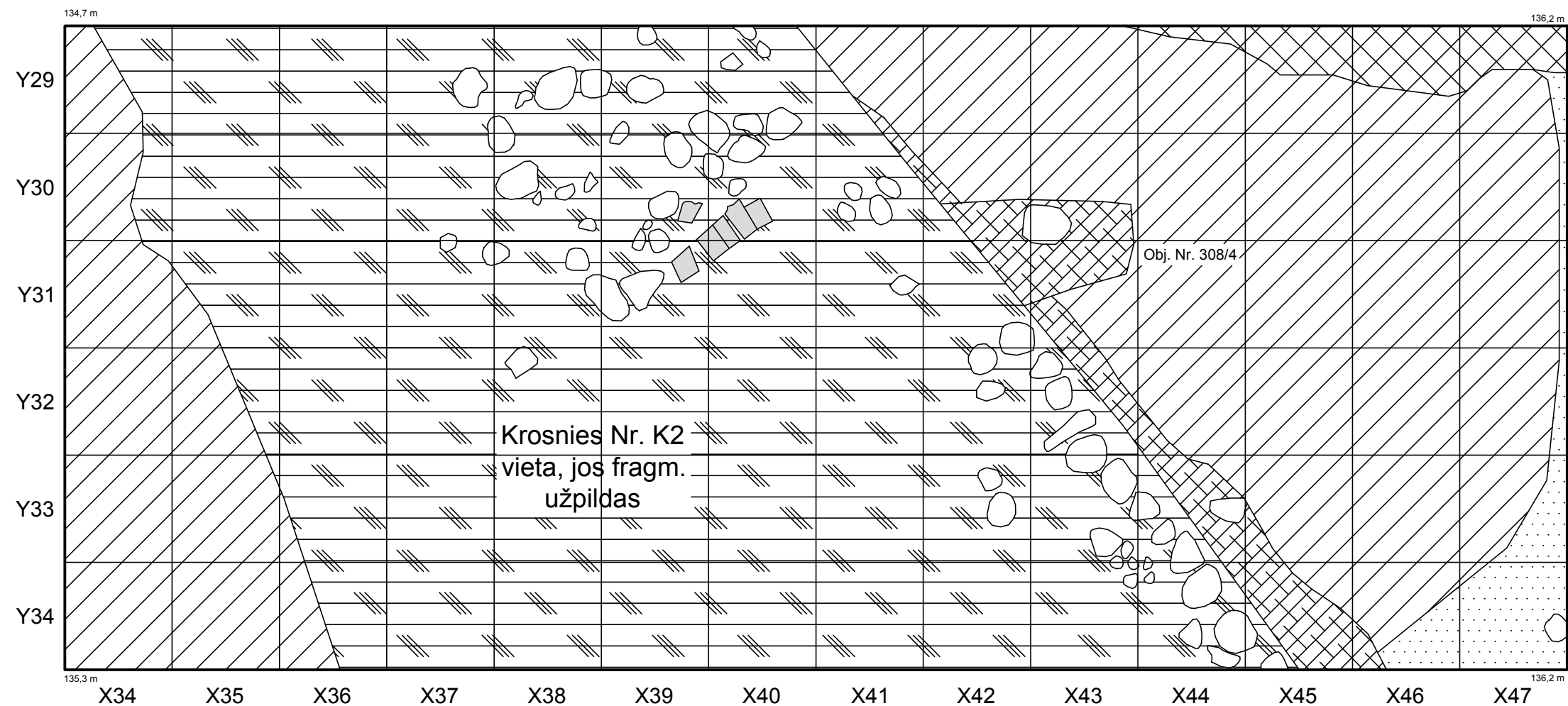

P-38 t. p. ž. sluoksniu (XV a.) sit. planas (0,1-0,15 m gylis)

M1:50

Brėžinys Nr. 163

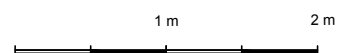
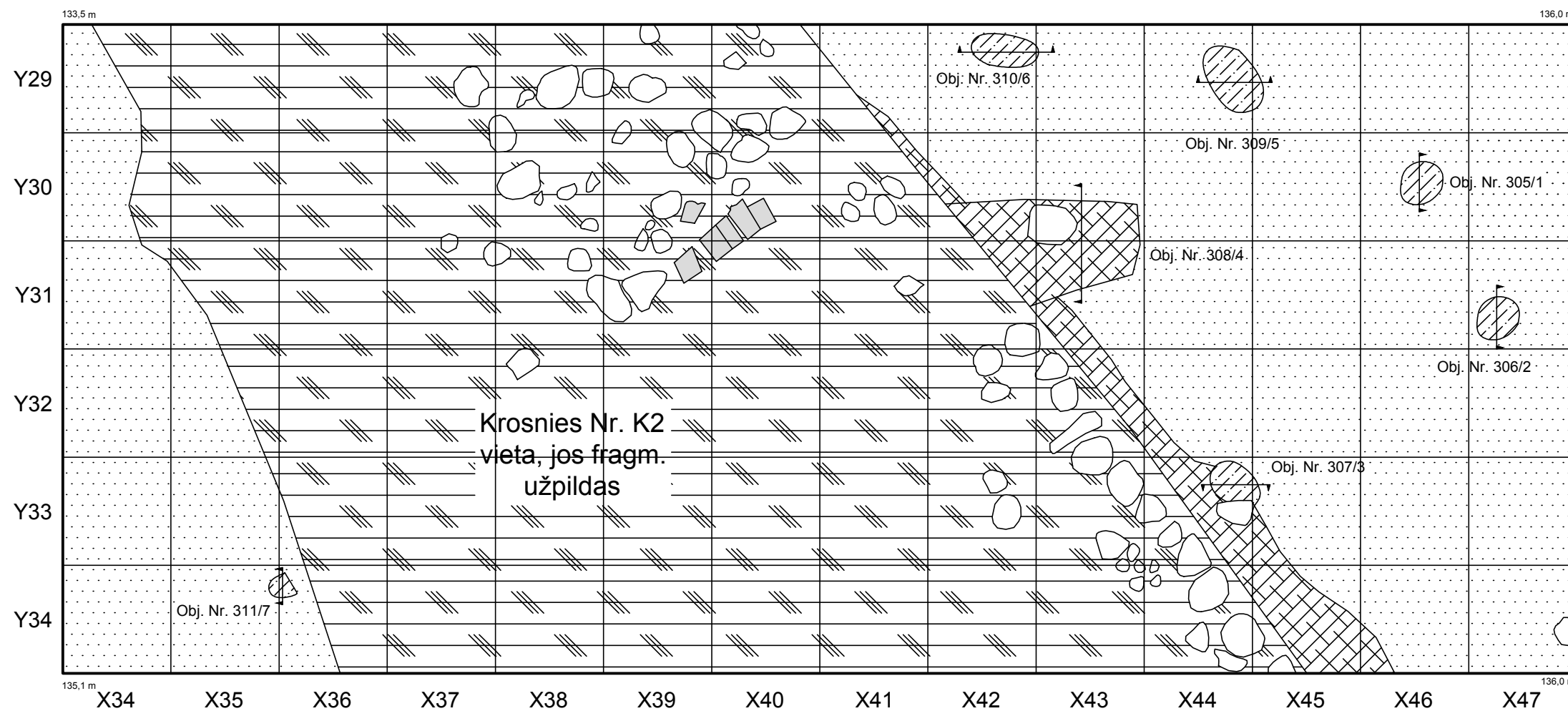

P-38 obj. sit. planas įžemyje (0,25–0,3 m gylis)

M1:50

Brėžinys Nr. 164



# Obj. Nr. 307/3

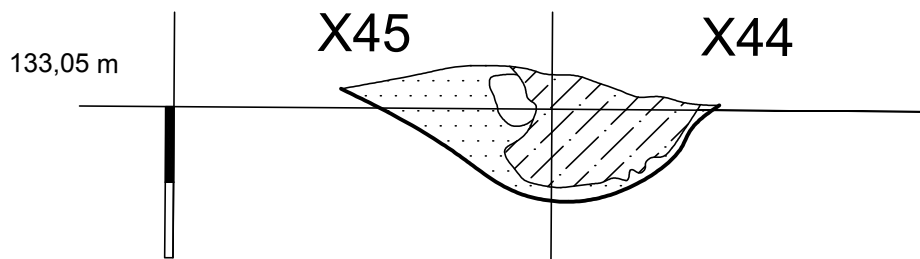

# Obj. Nr. 308/4

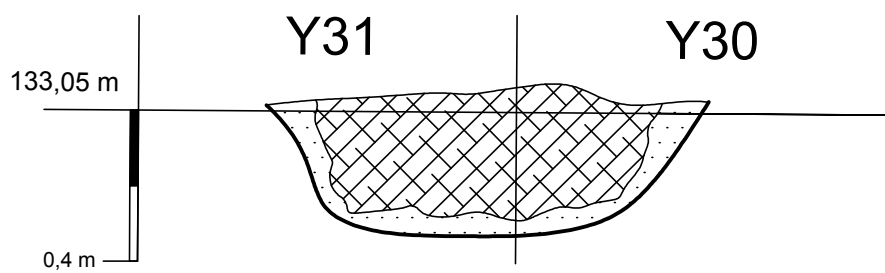

# Obj. Nr. 311/7

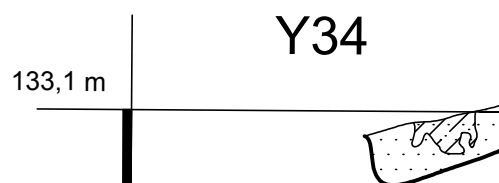

Obj. Nr. 307/3–308/4, 311/7

M1:20

Brėžinys Nr. 165

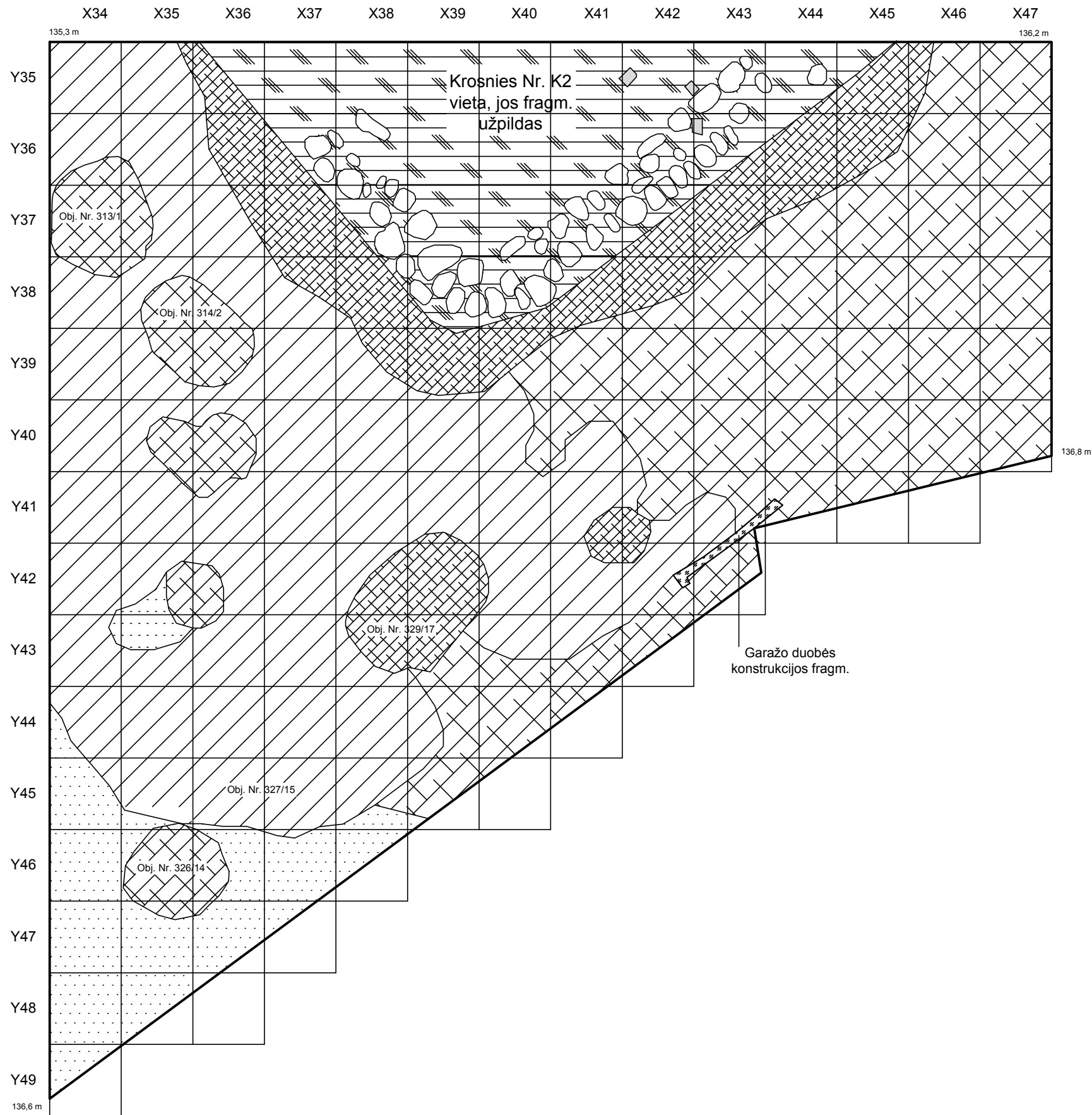

P-39 t. p. ž. sluoksnio (XV a.) sit. planas (0,1–0,2 m gylis)

M1:60

Brėžinys Nr. 166

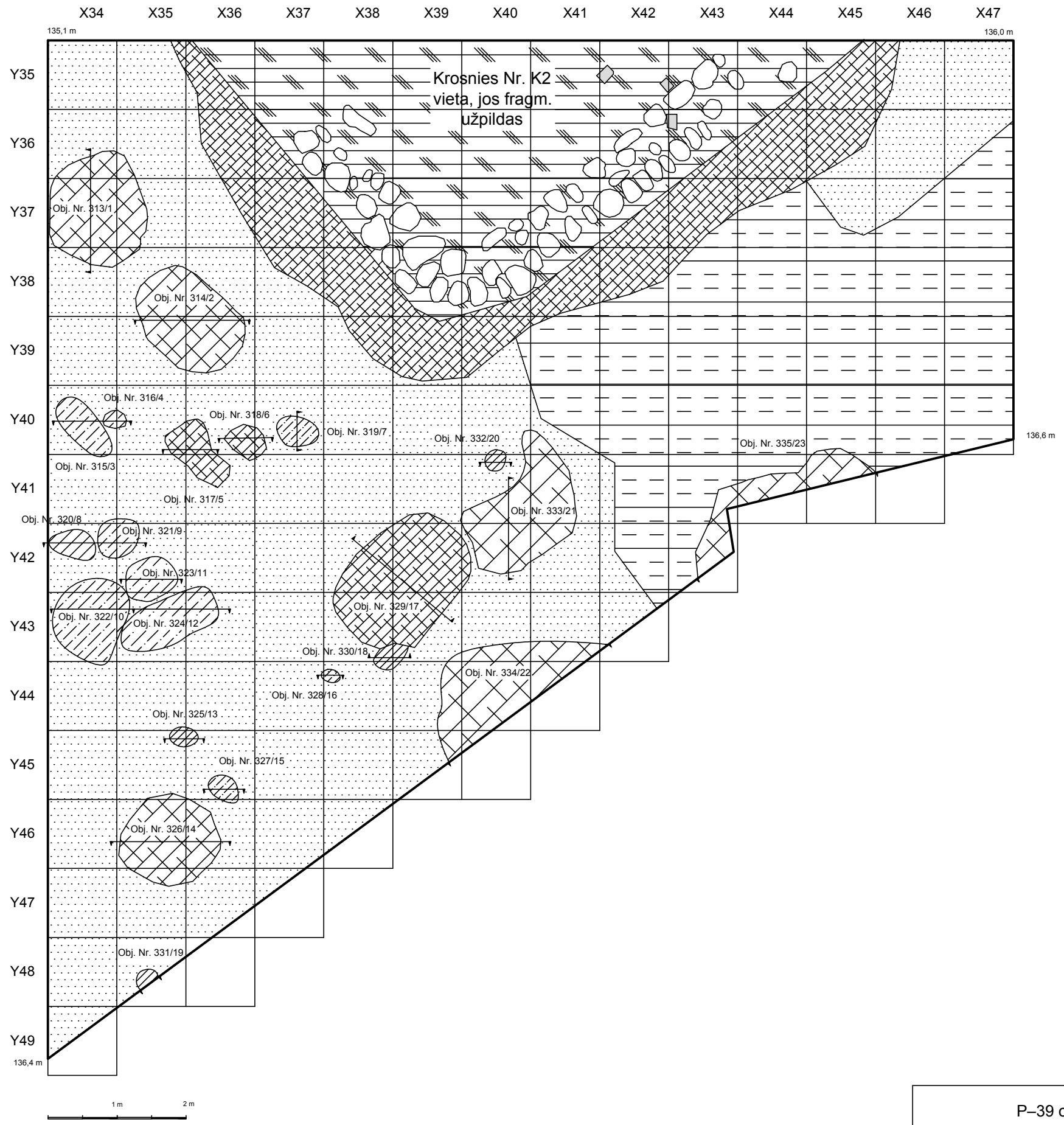

P-39 obj. sit. planas įžemyje (0,4 m gylis)

M1:60

Brėžinys Nr. 167

Obj. Nr. 313/1

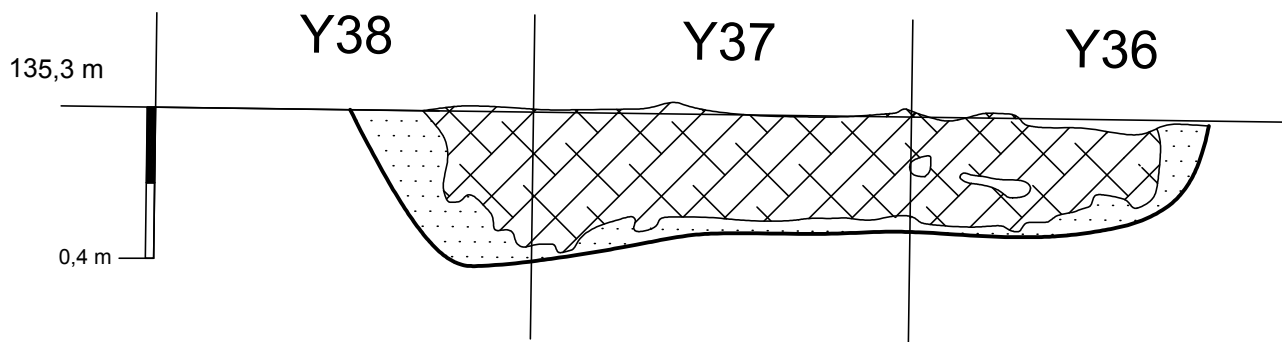

Obj. Nr. 313/1

M1:20

Brėžinys Nr. 168

Obj. Nr. 314/2

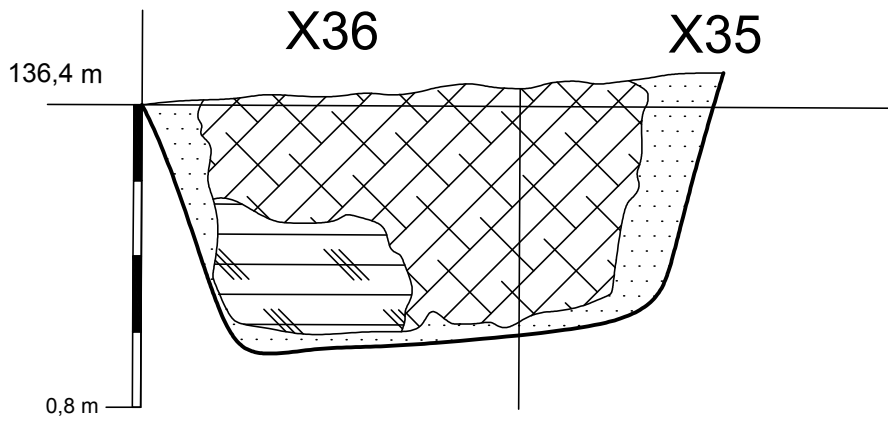

Obj. Nr. 316/4

Obj. Nr. 315/3

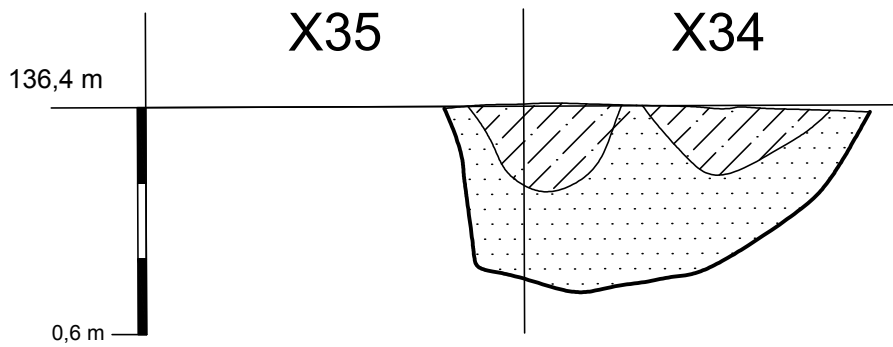

Obj. Nr. 317/5

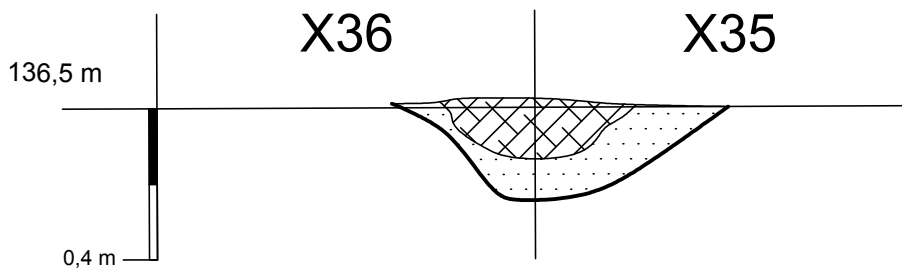

Obj. Nr. 314/2–317/5
M1:20
Brėžinys Nr. 169

Obj. Nr. 318/6

Obj. Nr. 319/7

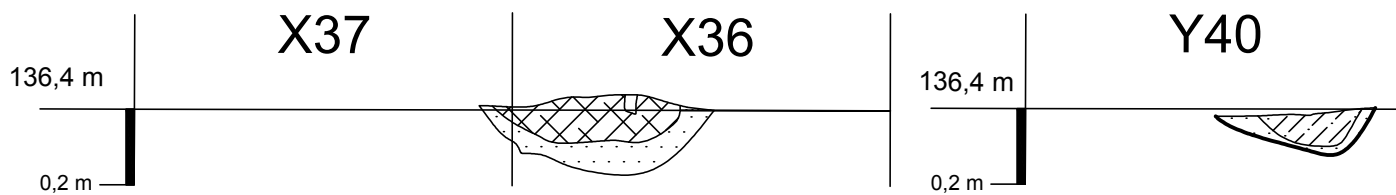

Obj. Nr. 320/8

Obj. Nr. 321/9

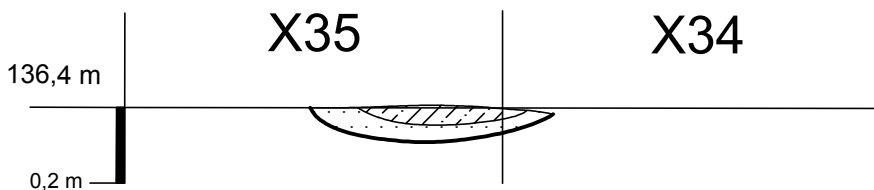
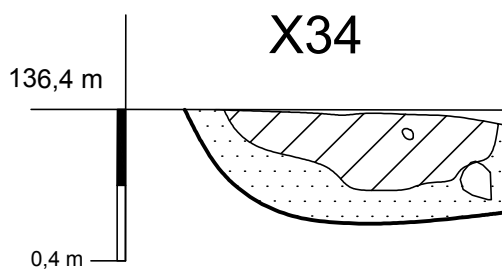

Obj. Nr. 323/11

Obj. Nr. 324/12

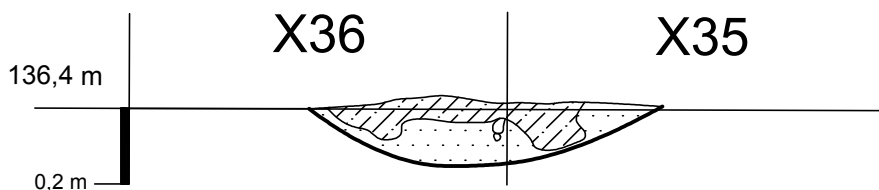
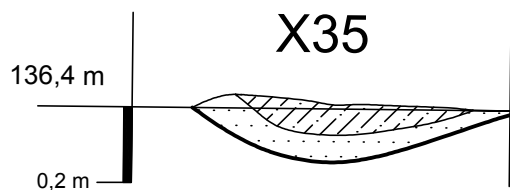

Obj. Nr. 325/13

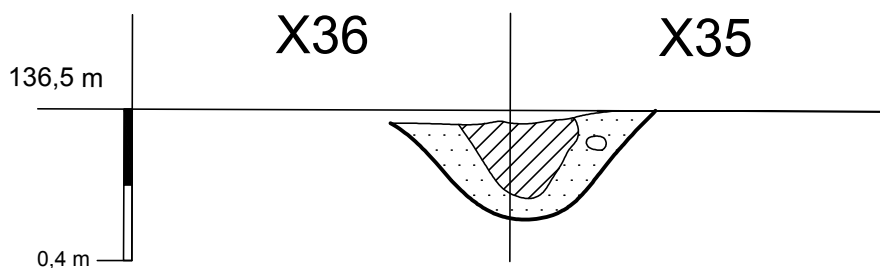

Obj. Nr. 318/6–325/13

M1:20

Brėžinys Nr. 170

Obj. Nr. 326/14

Obj. Nr. 327/15

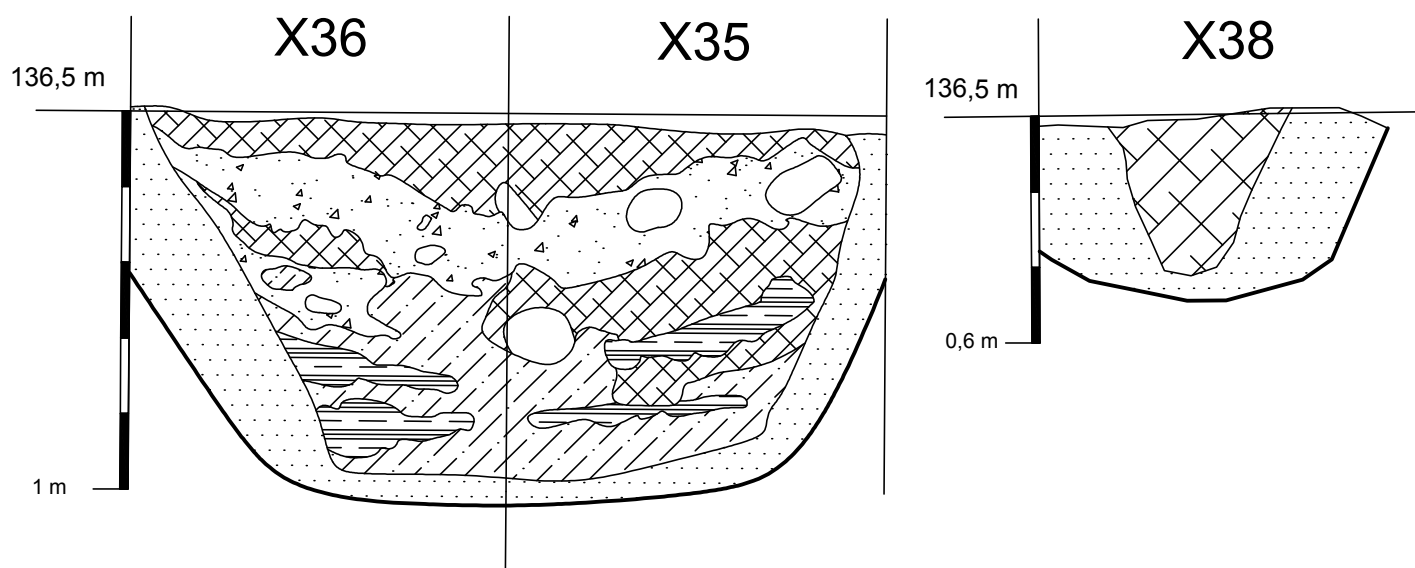

Obj. Nr. 328/16

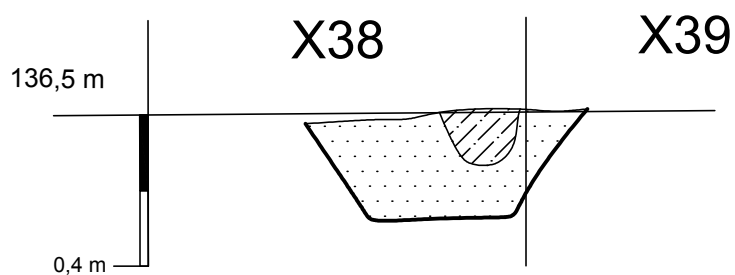

Obj. Nr. 329/17

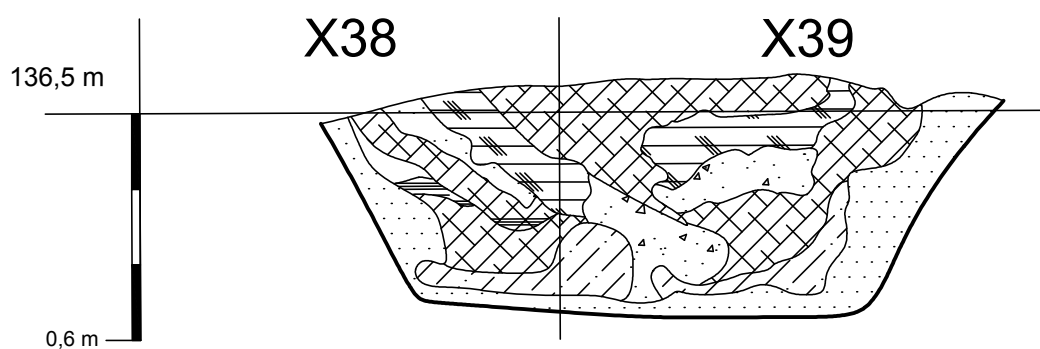

0,2 m 1 m

Obj. Nr. 326/14–329/17

M1:20

Brėžinys Nr. 171

Obj. Nr. 330/18

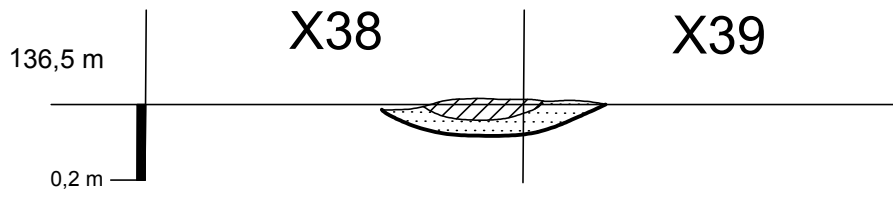

Obj. Nr. 332/20

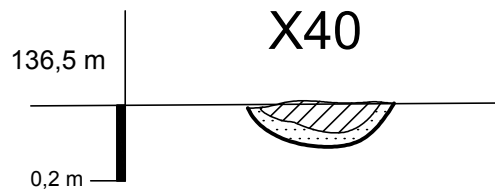

Obj. Nr. 333/21

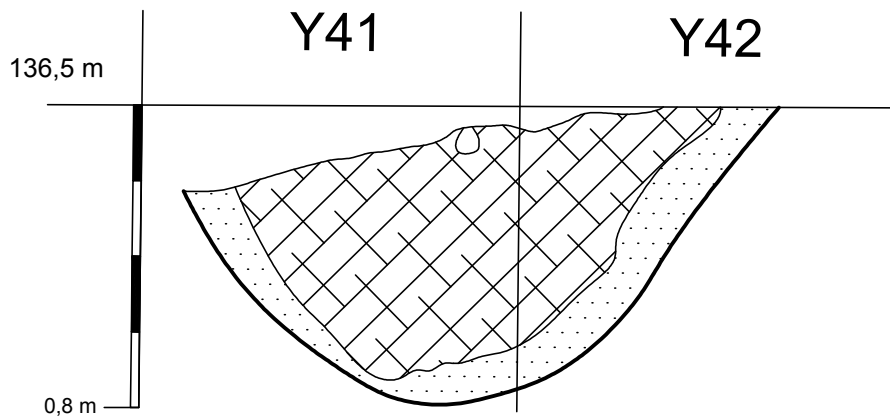

Obj. Nr. 330/18–333/21, 337/1–338/2

M1:20

Brėžinys Nr. 172



P-38 P sienos pjūvis (Kv. X46-x45)

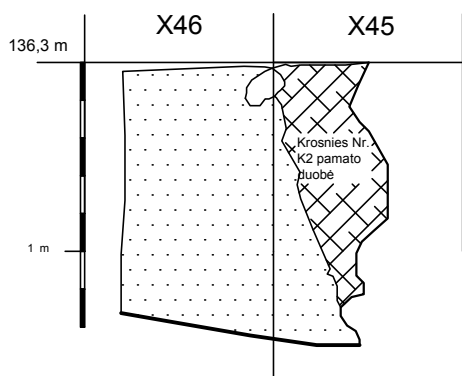

P-38 P sienos pjūvis (Kv. X36-X34)

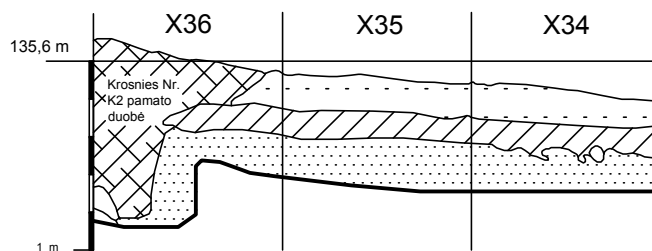

P-39 P sienos pjūvis (Kv. X45-X43)

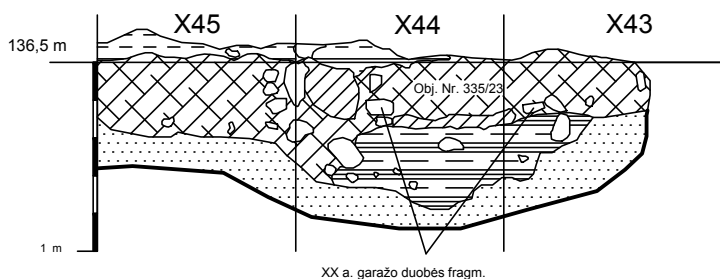

P-39 P sienos pjūvis (Kv. X42-X39)

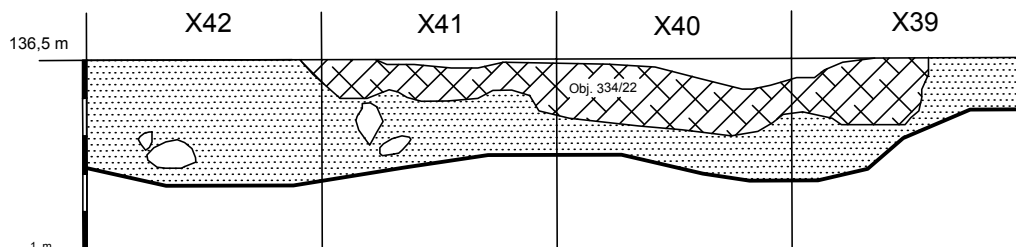

P-39 V sienos pjūvis (Kv. Y44-Y43)

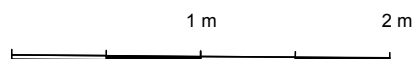
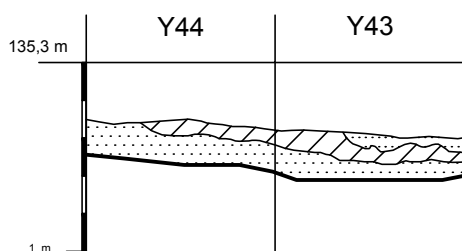

P-38 P sienos pjūvis (Kv. X46-x45);  
 P-38 P sienos pjūvis (Kv. X36-X34);  
 P-39 P sienos pjūvis (Kv. X45-X39);  
 P-39 V sienos pjūvis (Kv. Y44-Y43)

M1:40

Brēžinys Nr. 173

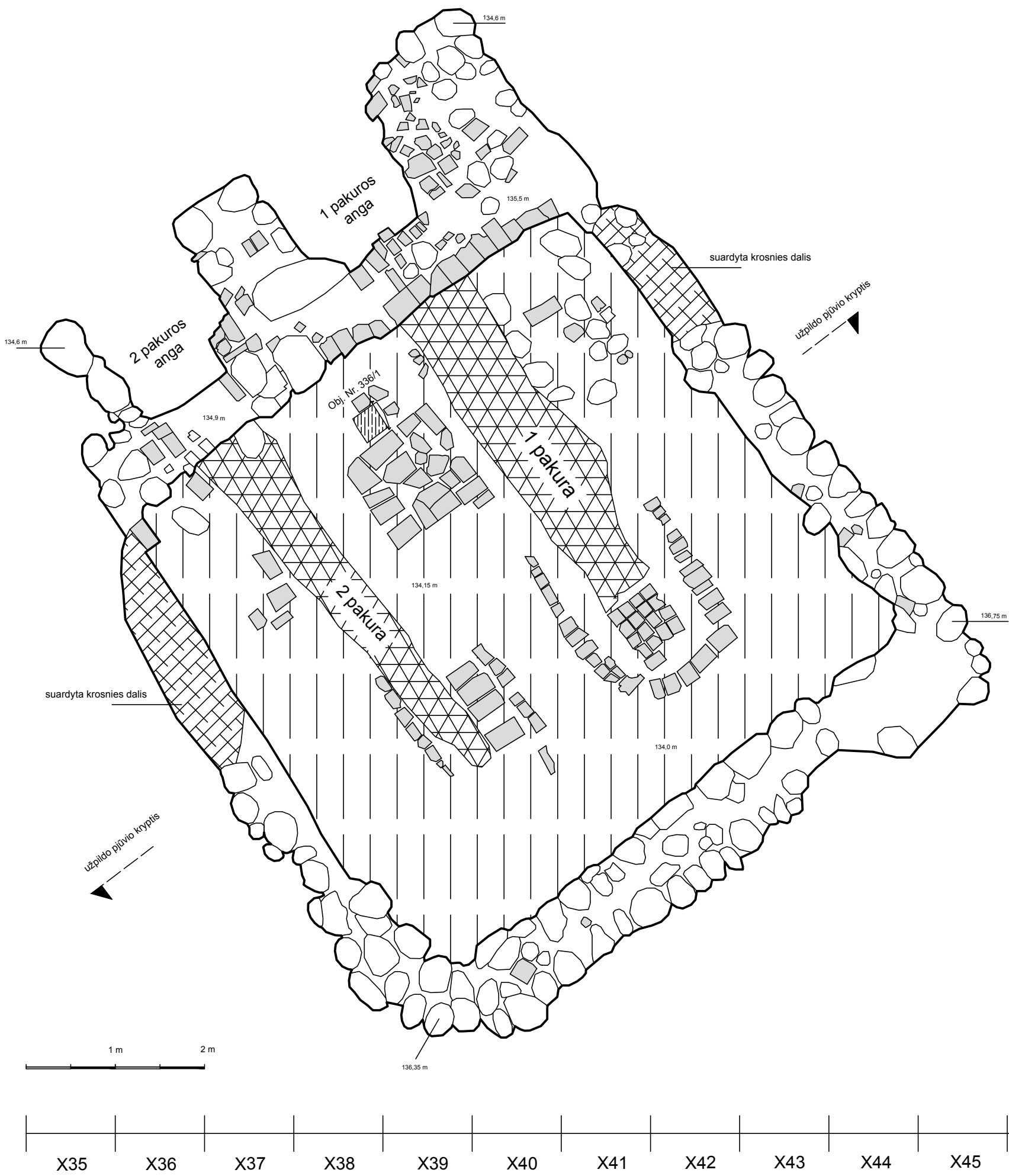

P-38

63-D

Krosnies Nr. K2 planas

M1:40

Brėžinys Nr. 174

### Krosnies Nr. K2 užpildo pjūvis

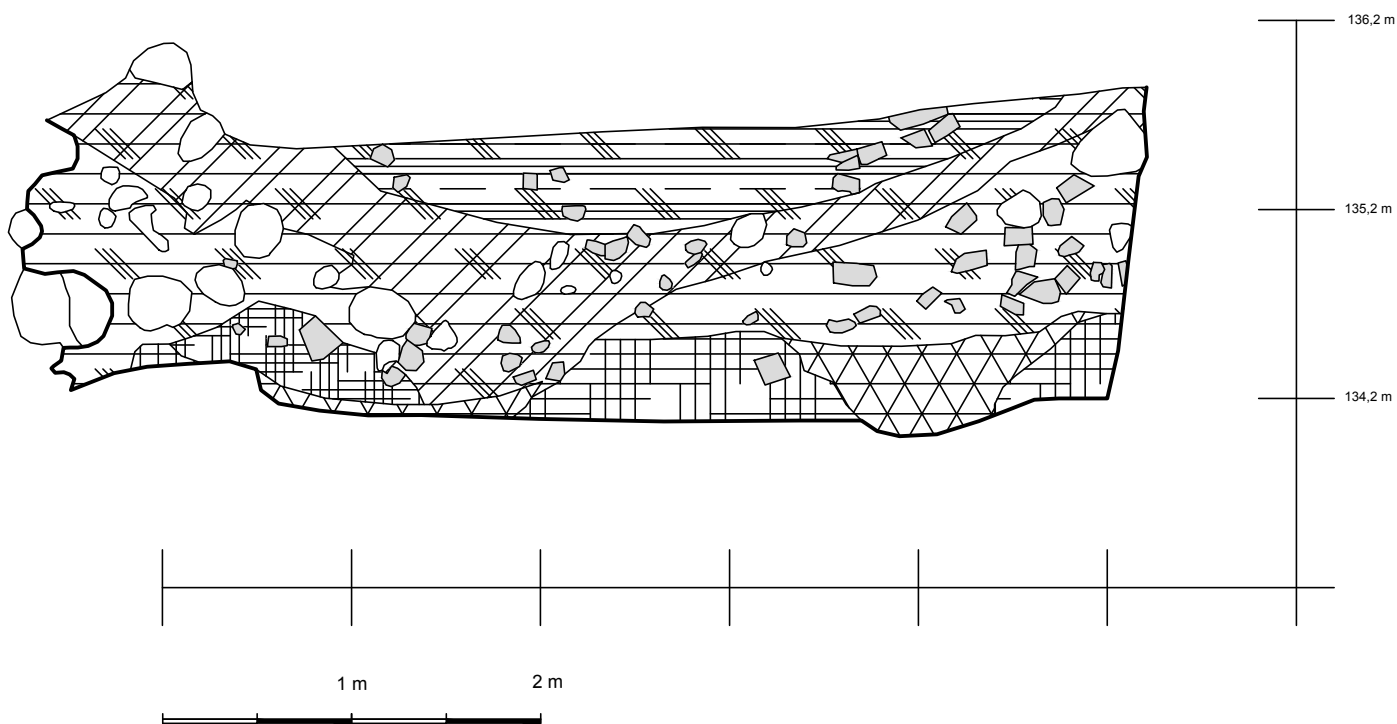

### Krosnis Nr. K2 išorė (Š pusė)

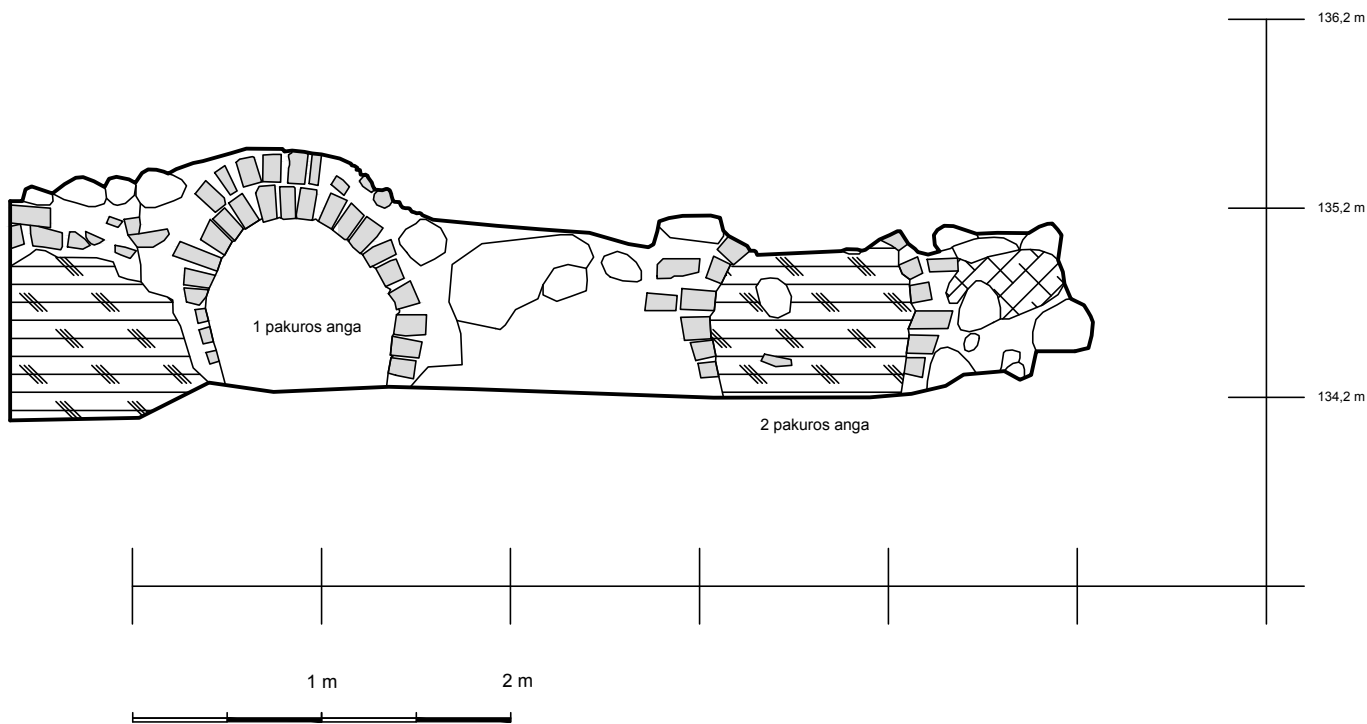

Krosnies Nr. K2 užpildo pjūvis ir išorė (Š pusė)

M1:40

Brėžinys Nr. 175

### Krosnis Nr. K2 Š siena (vidus)

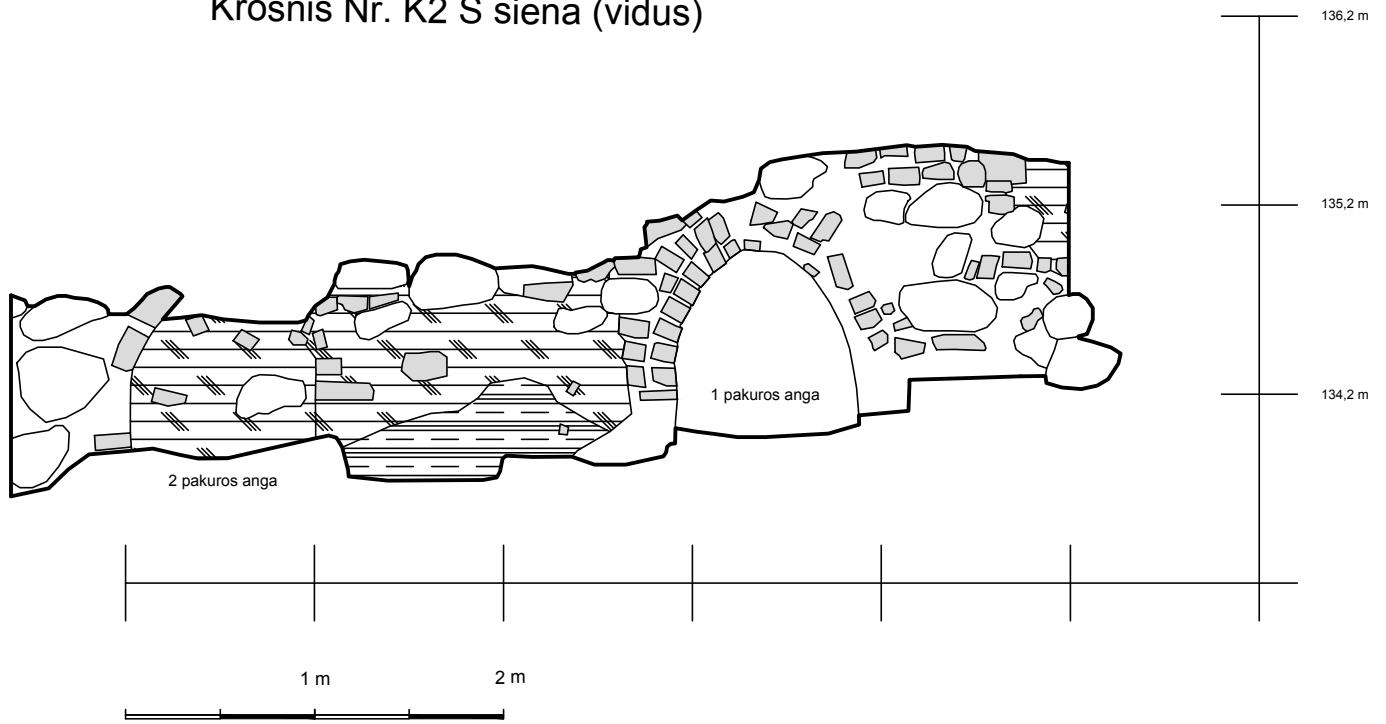

### Krosnis Nr. K2 V siena (vidus)

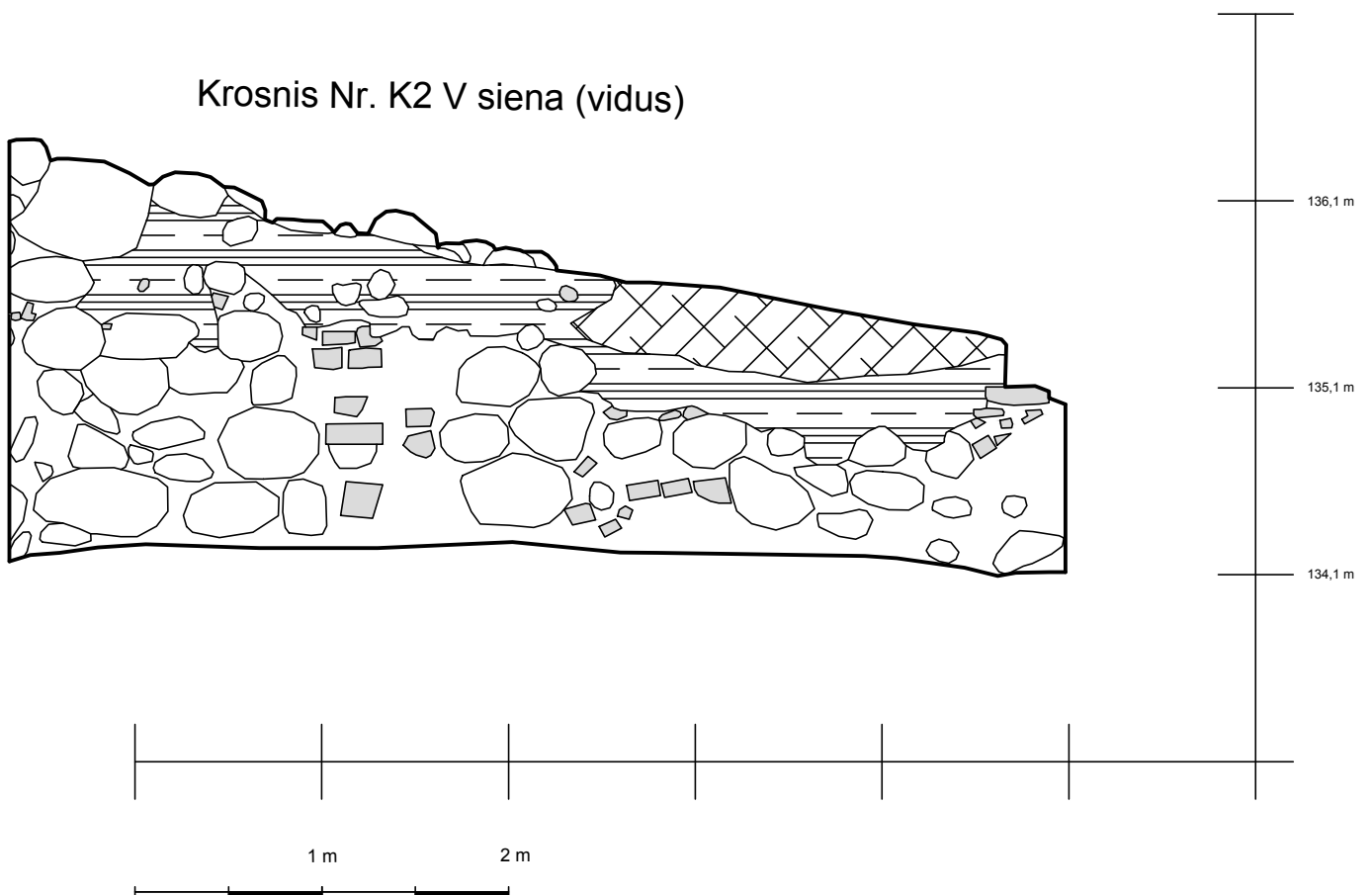

Krosnies Nr. K2 Š, V siena

M1:40

Brėžinys Nr. 176

Krosnis Nr. K2 R siena (vidus)

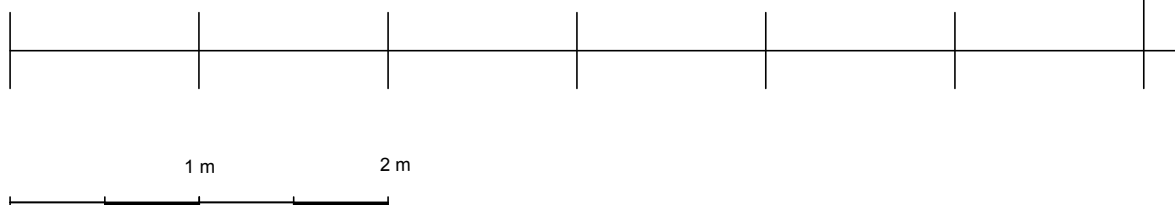
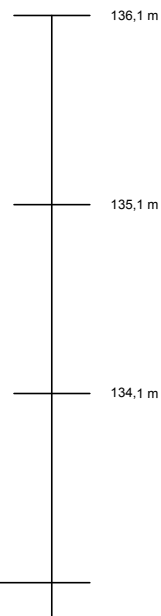
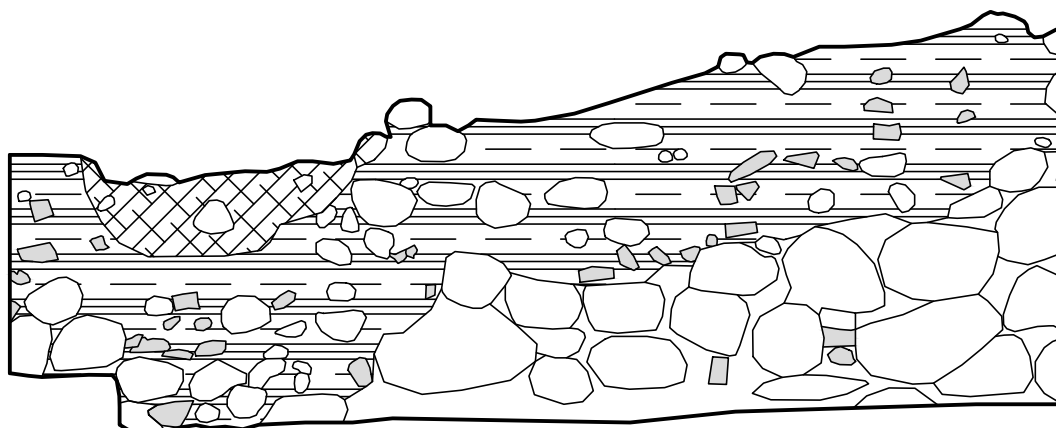

Krosnis Nr. K2 P siena (vidus)

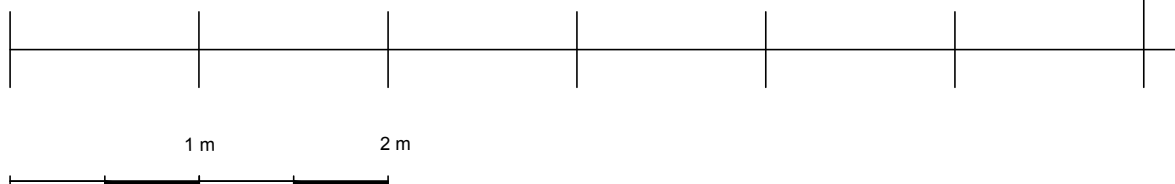
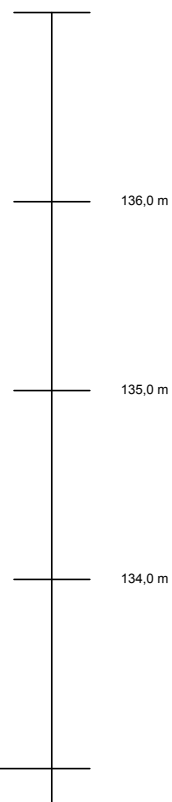
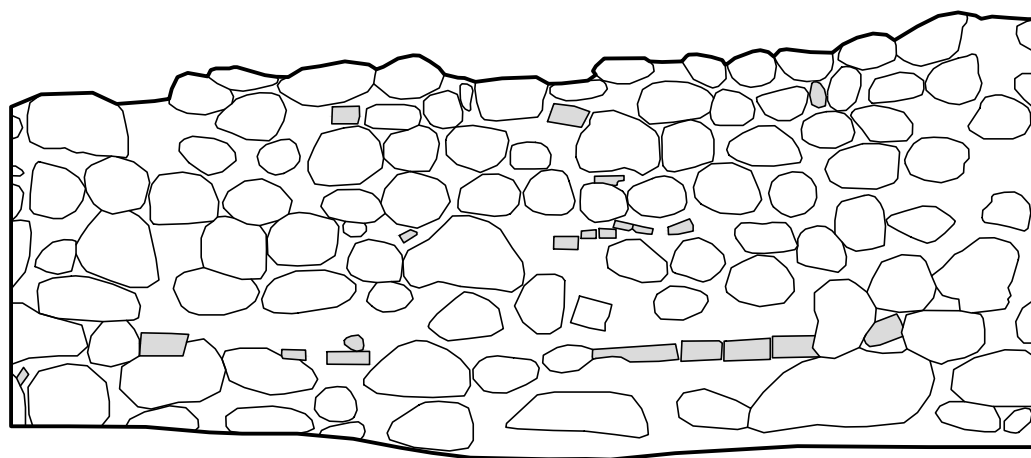

Krosnies Nr. K2 R, P siena

M1:40

Brėžinys Nr. 177

P-41 obj. sit. planas įžemyje (0,3–0,5 m gylis)

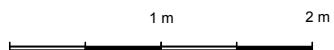
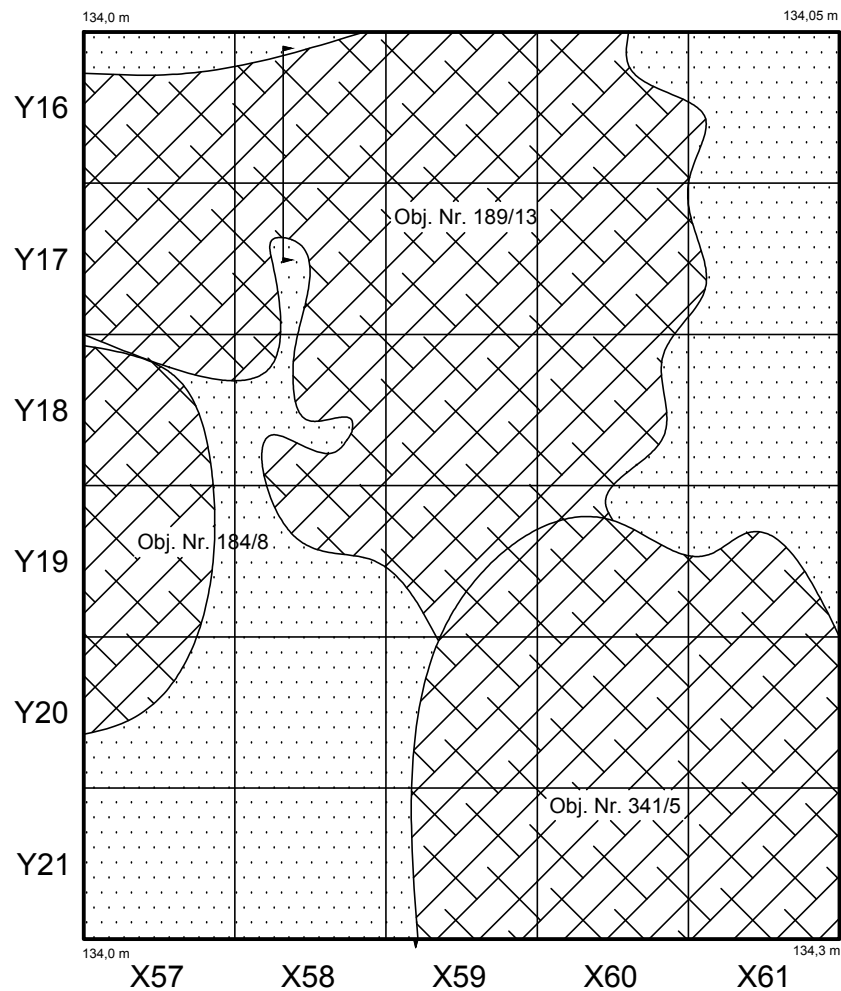

P-40 obj. sit. planas įžemyje (0,3–0,6 m gylis)

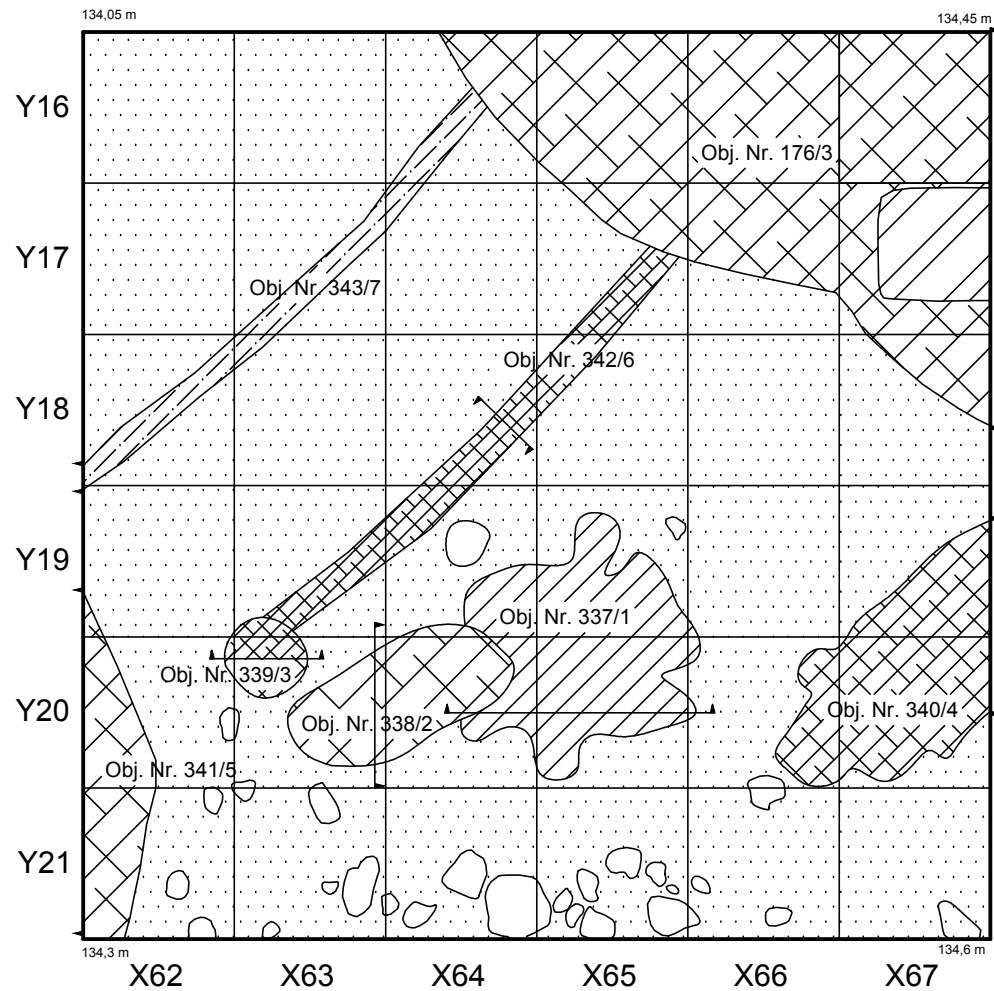

P-40 obj. sit. planas įžemyje (0,3–0,6 m gylis);  
P-41 obj. sit. planas įžemyje (0,3–0,5 m gylis)

M1:50

Brėžinys Nr. 178

Obj. Nr. 337/1

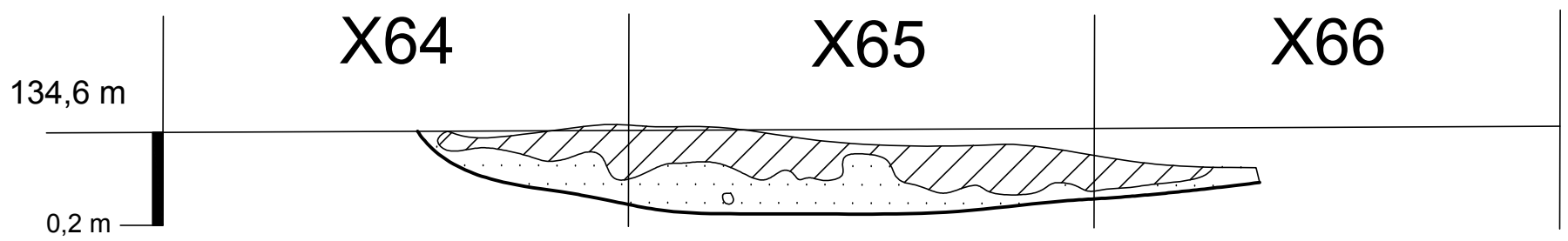

Obj. Nr. 338/2

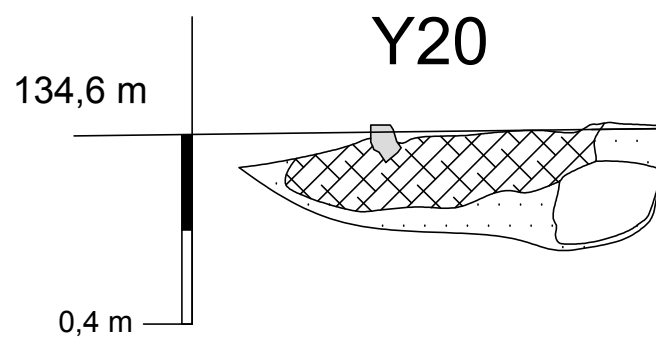

Obj. Nr. 337/1–338/2

M1:20

Brėžinys Nr. 179

Obj. Nr. 339/3

Obj. Nr. 342/6

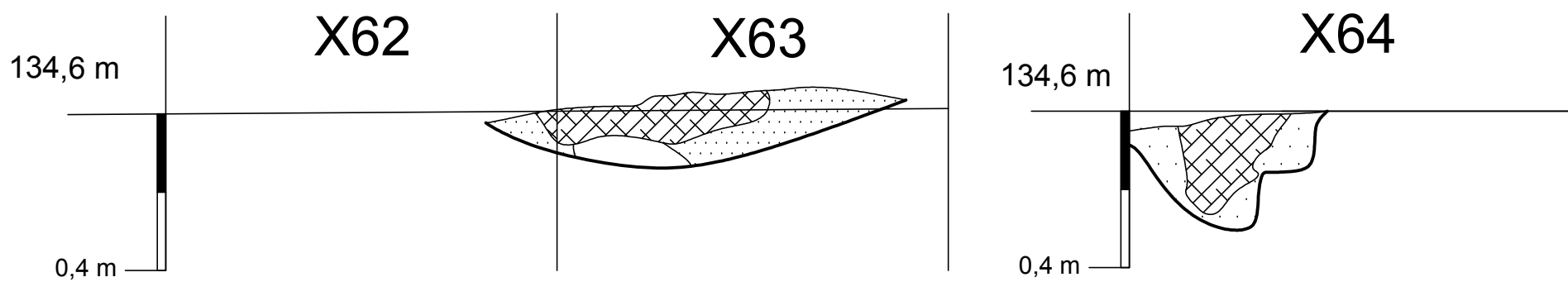

Obj. Nr. 189/13

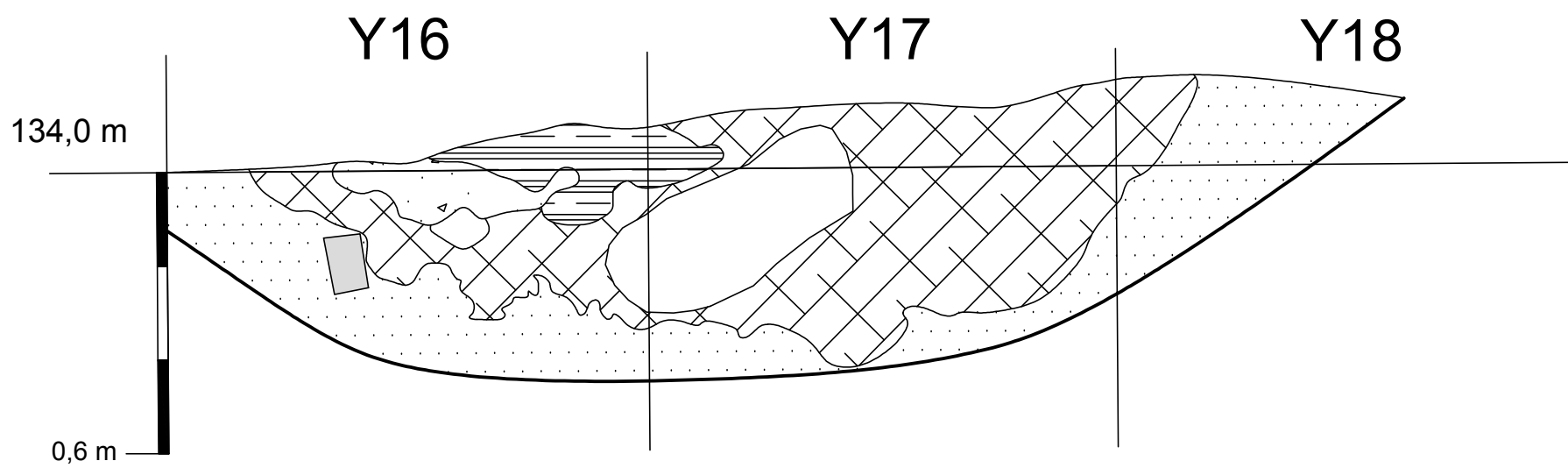

Obj. Nr. 339/3–342/6, 189/13

M1:20

Brėžinys Nr. 180



P-40 R sienos pjūvis

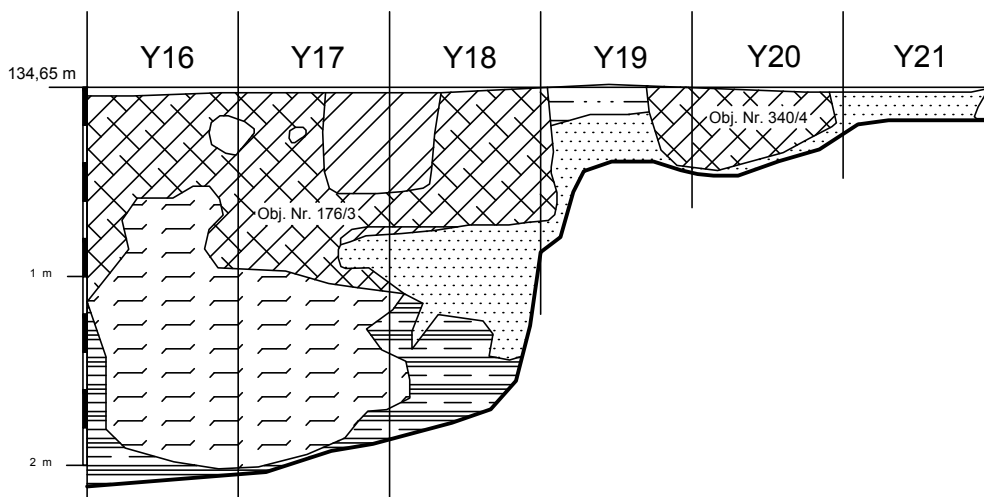

P-40 (Kv. Y19–Y16) V sienos pjūvis

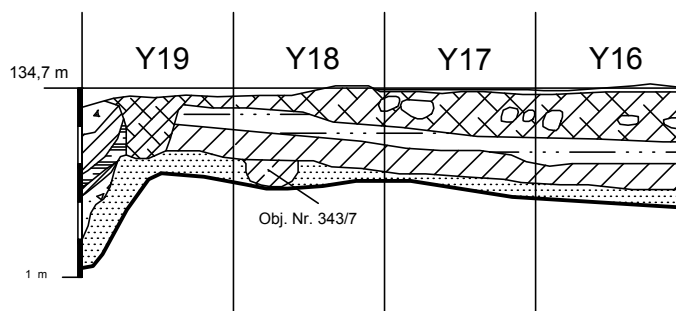

P-40 (Kv. X62) ir P-41 (Kv. X61–X59) P sienos pjūvis

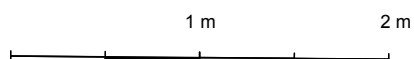
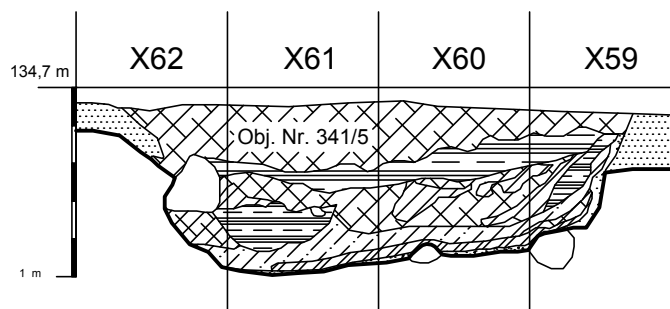

P-40 R sienos pjūvis;  
 P-40 V sienos pjūvis (Kv. Y19–Y16);  
 P-40 (Kv. X62) ir P-41 (Kv. X61–X59) P sienos pjūvis

M1:40

Brēžinys Nr. 181

Obj. Nr. 344/1

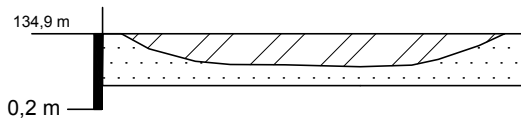

Obj. Nr. 345/2

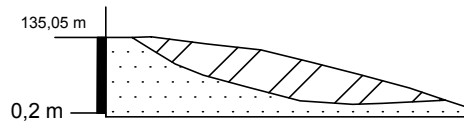

Obj. Nr. 346/3

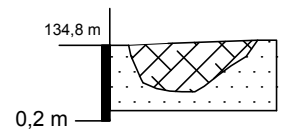

Obj. Nr. 347/4

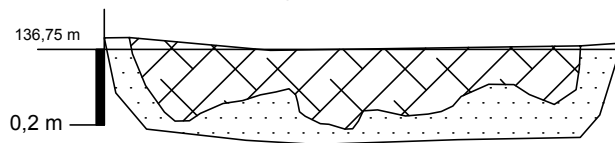

Obj. Nr. 348/5

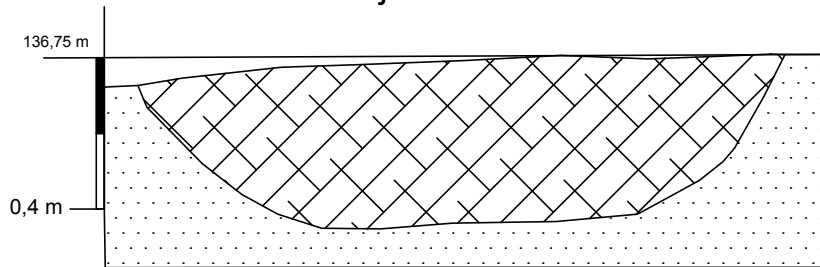

Obj. Nr. 349/6

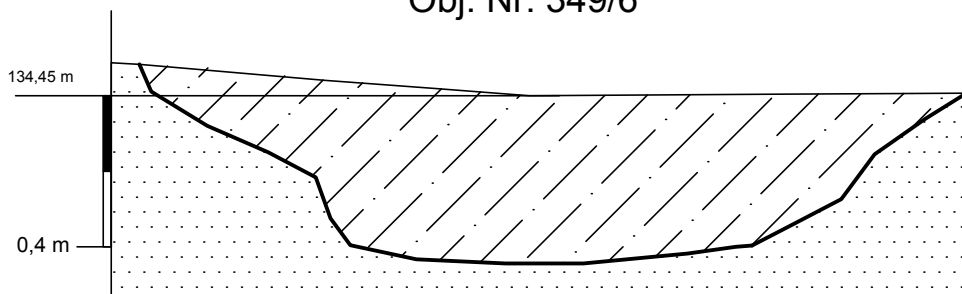

Obj. Nr. 344/1–349/6

M1:40

Brėžinys Nr. 182

Obj. Nr. 350/7

134,0 m

1 m

2 m

3 m

4 m

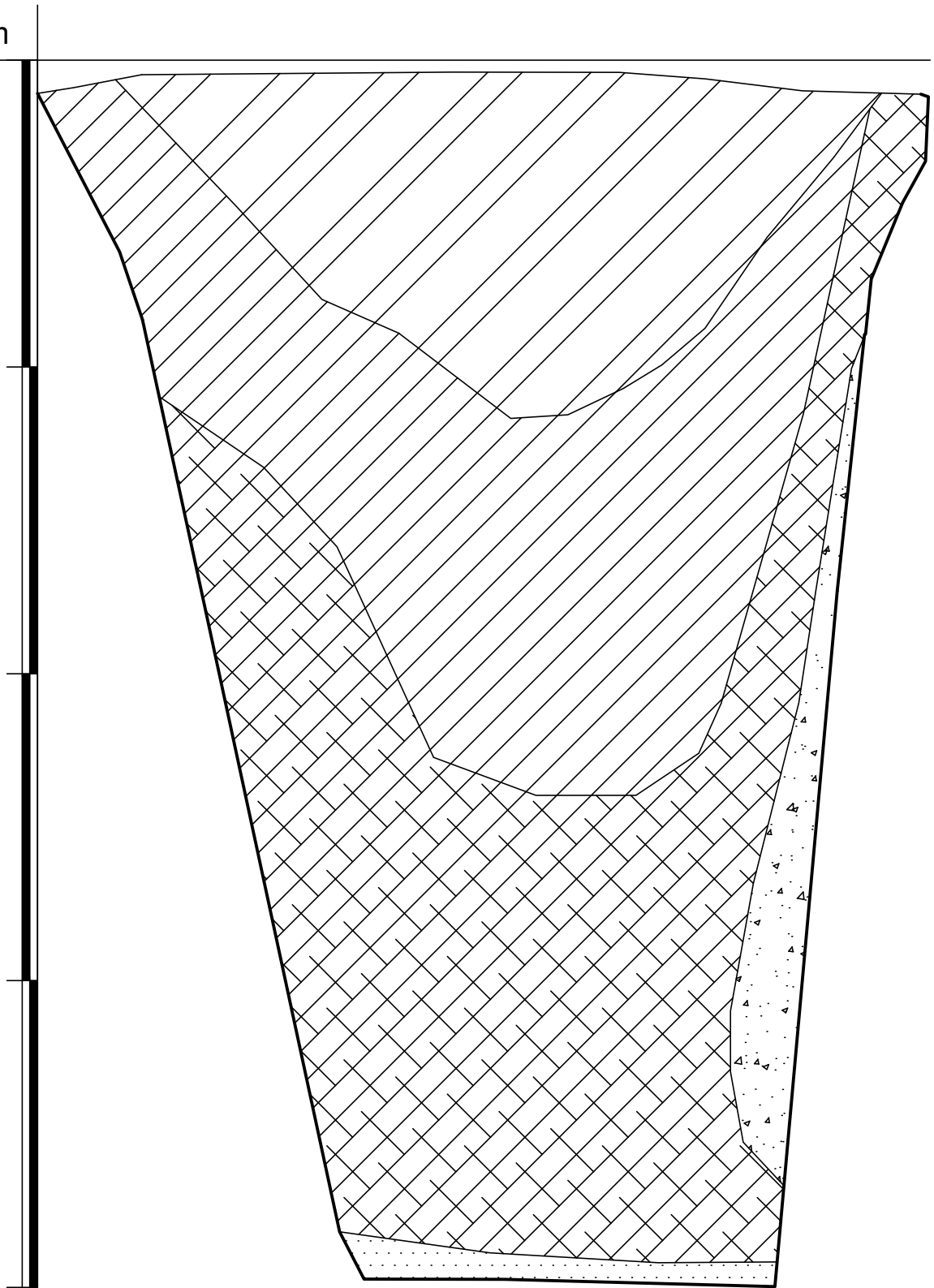

Obj. Nr. 350/7

M1:40

Brėžinys Nr. 183

Obj. Nr. 351/8

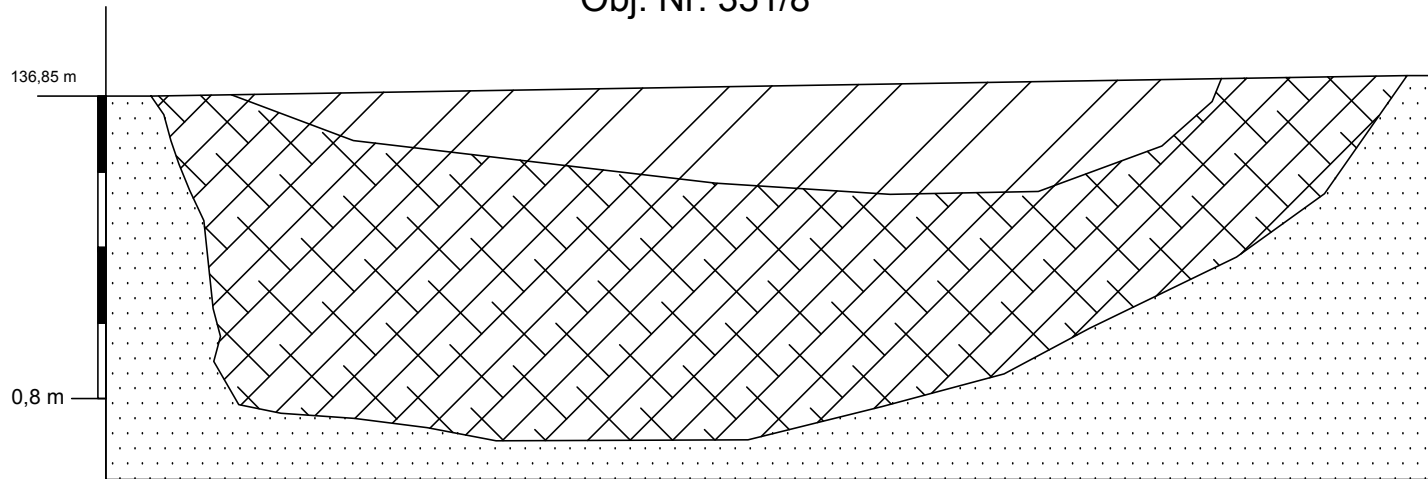

Obj. Nr. 353/10

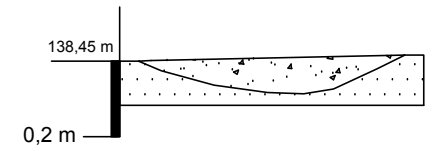

Obj. Nr. 354/11

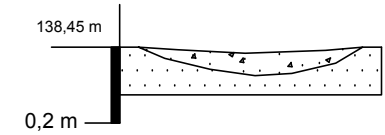

Obj. Nr. 352/9

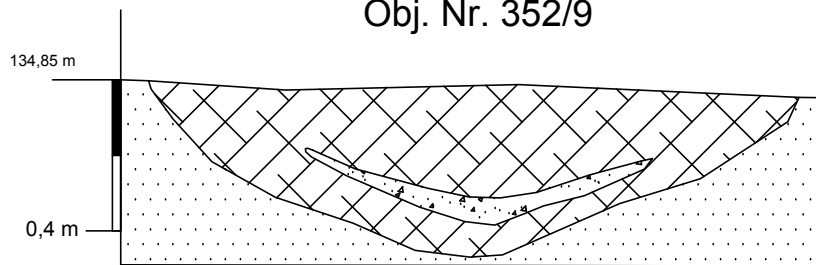

Obj. Nr. 356/13

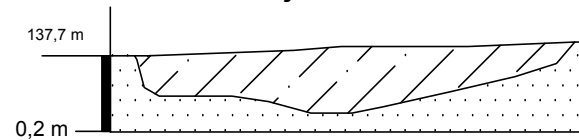

Obj. Nr. 359/16

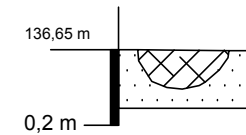

Obj. Nr. 357/14

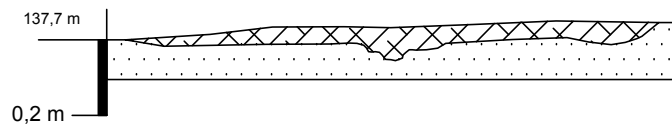

Obj. Nr. 358/15

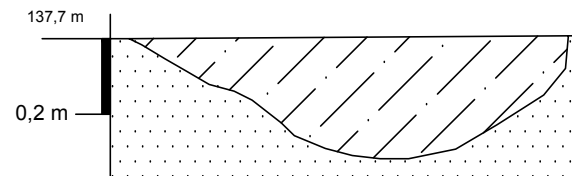

Obj. Nr. 360/17

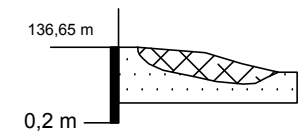

Obj. Nr. 351/8–354/11, 356/13–360/17

M1:20

Brėžinys Nr. 184

Obj. Nr. 361/18

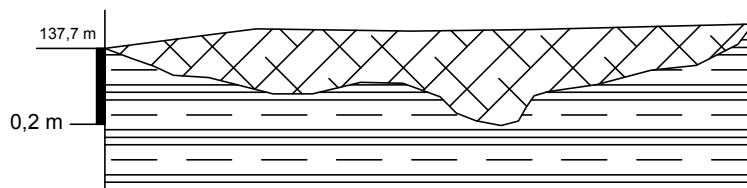

Obj. Nr. 362/19

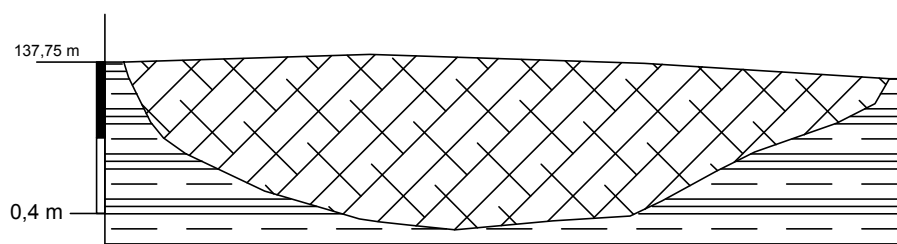

Obj. Nr. 363/20

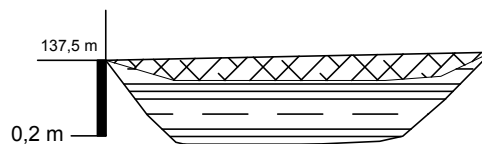

Obj. Nr. 364/21

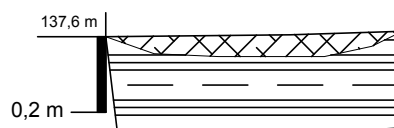

Obj. Nr. 381/8–362/21

M1:20

Brėžinys Nr. 185

137,5 m

1 m

2 m

1 m

2 m

1 griova

Pylimas

2 griova

1 m

2 m

137,6 m

1 m

2 m

3 m

Pylimas

2 griova

Obj. Nr. 355/12

M1:40

Brėžinys Nr. 186

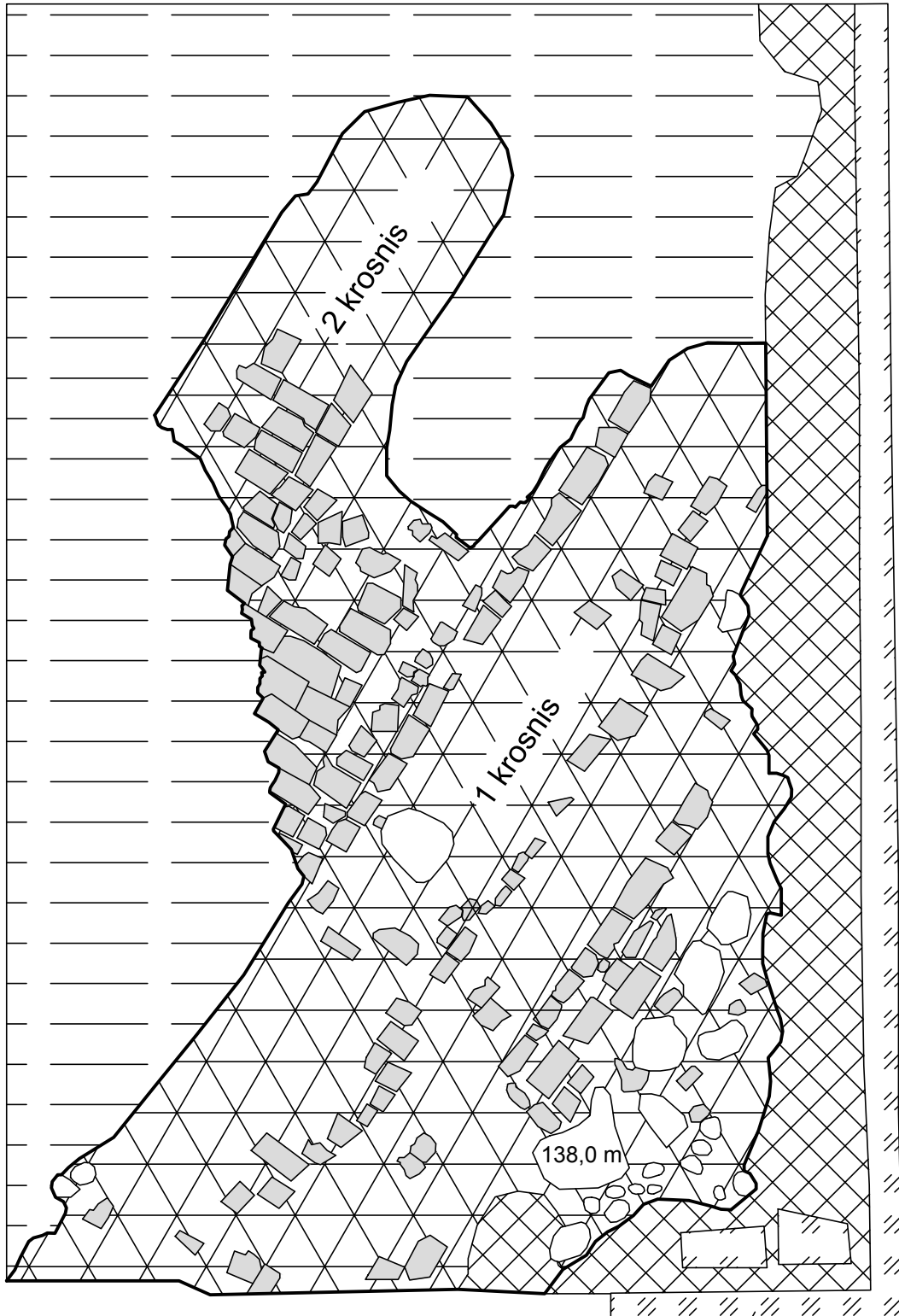

1 m      2 m



Mūrinės tvoros kraštas

Krosnies Nr. K5 planas

M1:40

Brėžinys Nr. 187